



Z, Ç VE G SESİ ÇALIŞMALARI



Adında "z" sesi bulunan varlıkları boyayalım.



"z" sesi ile başlayan varlıkları işaretleyelim.



👉 Büyük "Z" harfinin yazılış yönüne dikkat edelim. İçinden kalemimizle geçelim.

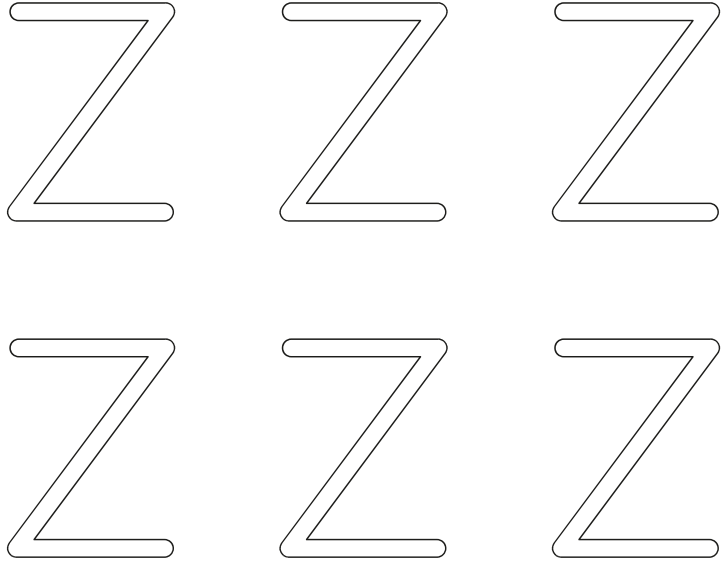
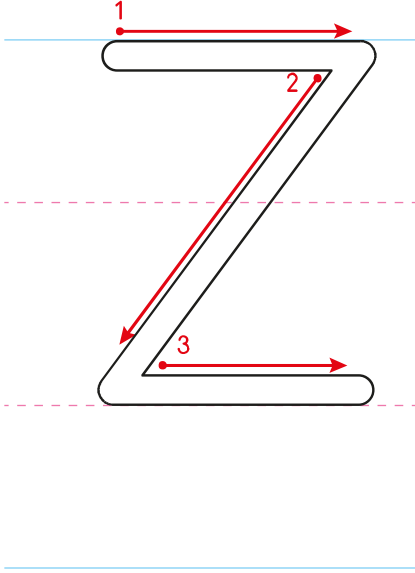

👉 "Z" harfinin yazılı olduğu balonları boyayalım.

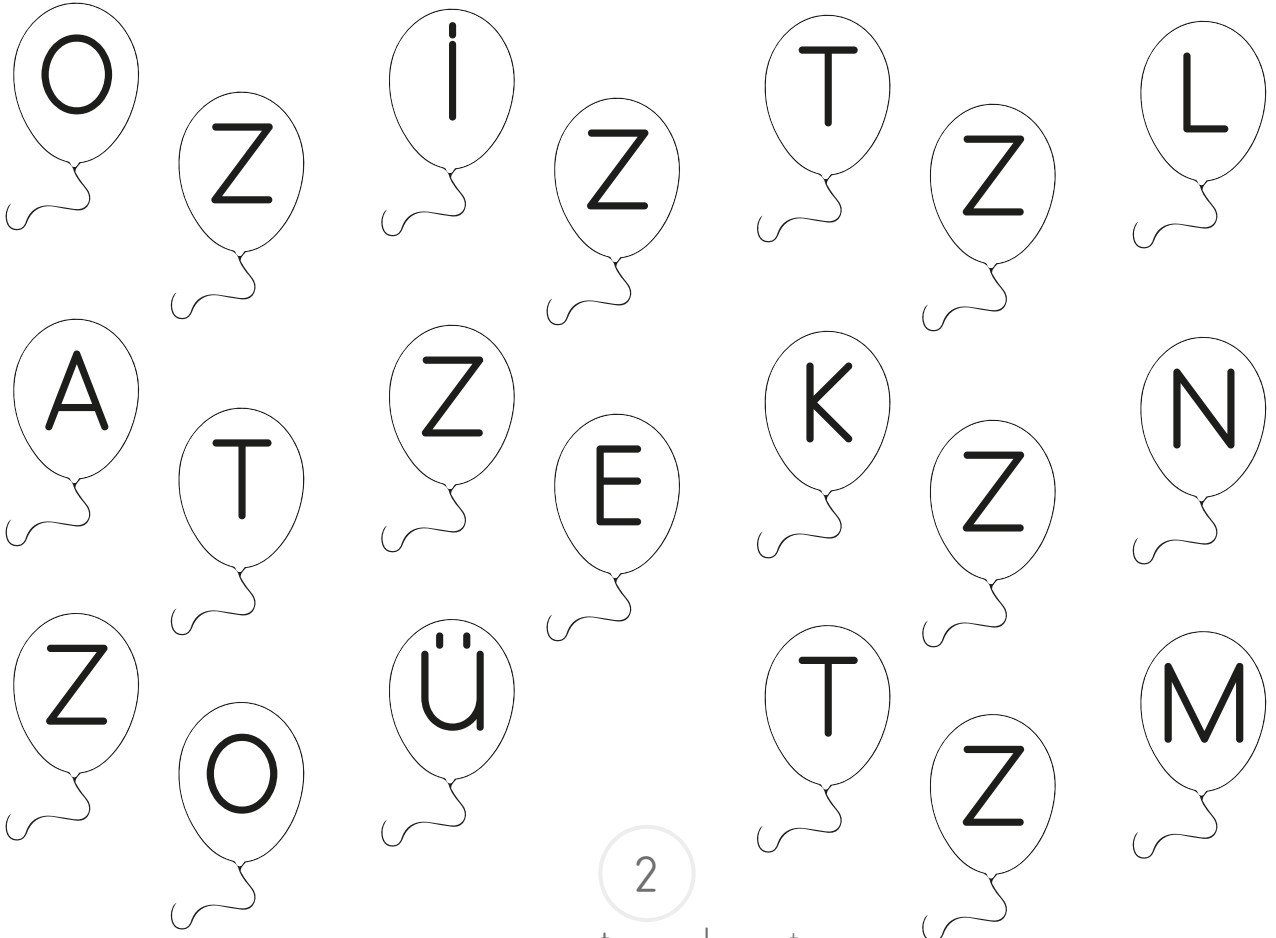

Yönergeleri uygulayalım.

• "Z" harfini boyayalım.

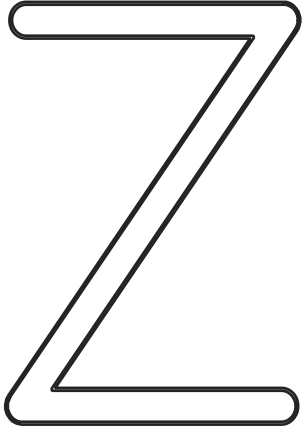

• "Z" harflerini bulup yuvarlak içine alalım.

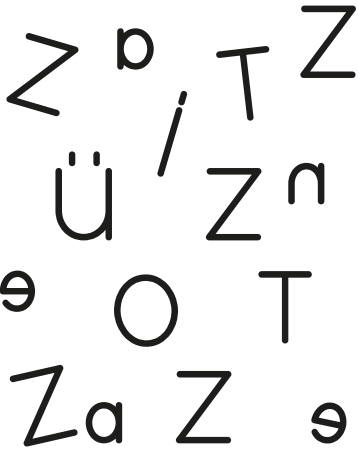

• Noktaları birleştirelim.



Yazma yönüne dikkat ederek "Z" harfini yazalım.

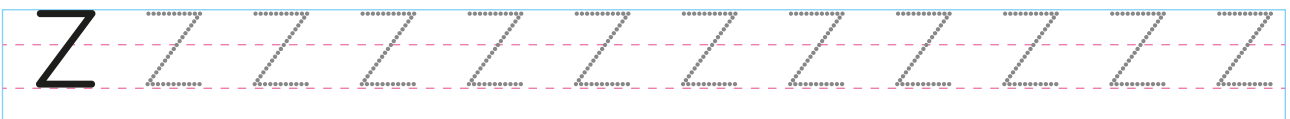
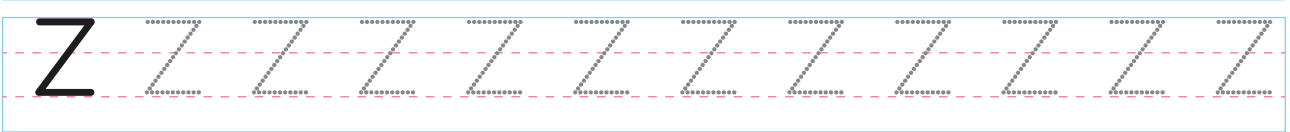
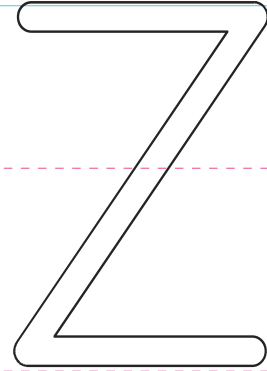
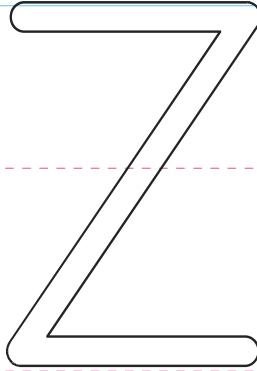
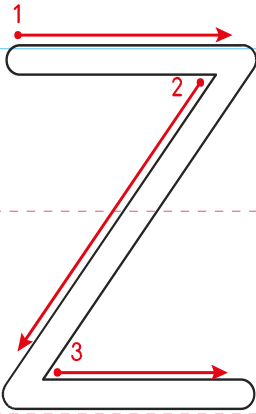



☞ "Z" harfini yazalım.

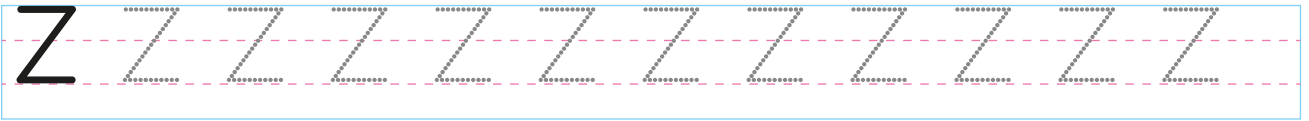
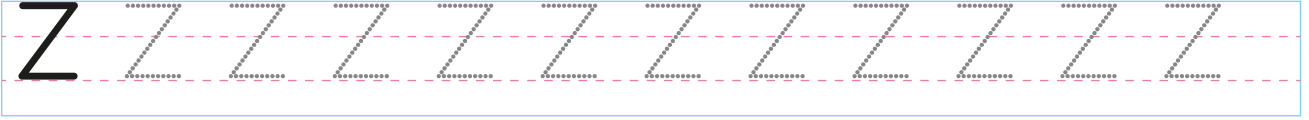
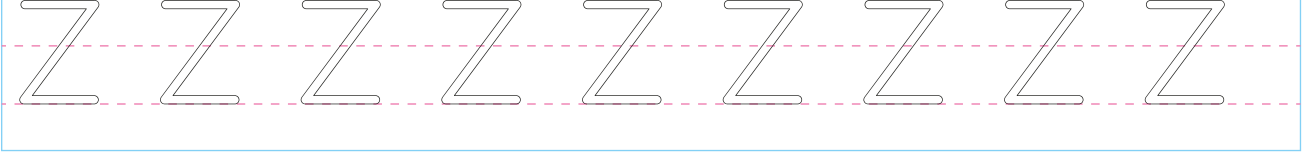



☞ Küçük "z" harfinin yazılış yönüne dikkat edelim. İçinden kalemimizle geçelim.

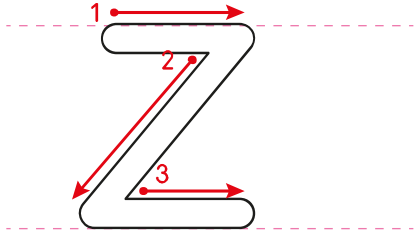

☞ "z" harfinin yazılı olduğu yıldızları boyayalım.



Yönergeleri uygulayalım.

• "z" harfini boyayalım.

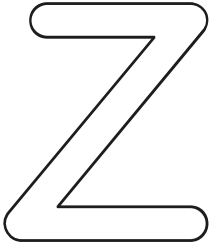

• "z" harflerini bulup yuvarlak içine alalım.

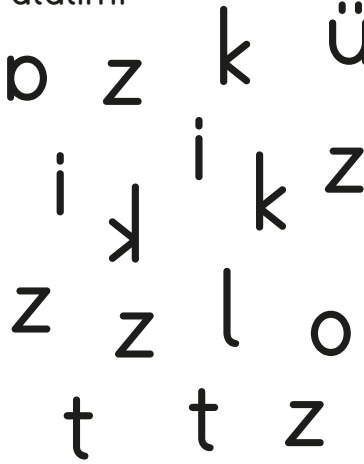

• Noktaları birleştirelim.

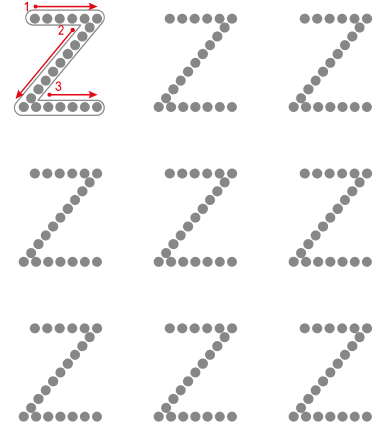

Yazma yönlerine dikkat ederek "z" harfini yazalım.

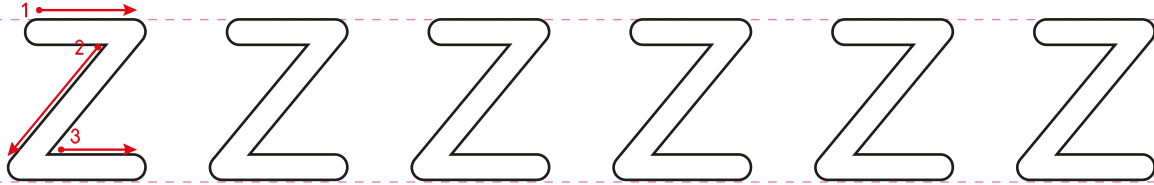



👉 "z" harfini yazalım.

Z Z Z Z Z Z Z Z Z Z Z Z

Z Z Z Z Z Z Z Z Z Z Z Z Z Z Z Z Z

Z Z Z

Z

Z

Z

Z

Z

Z

Z

Z

Z



👉 Büyük "Z" ve küçük "z" harfini yazalım.

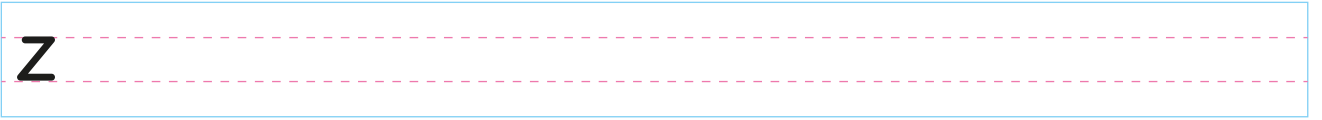
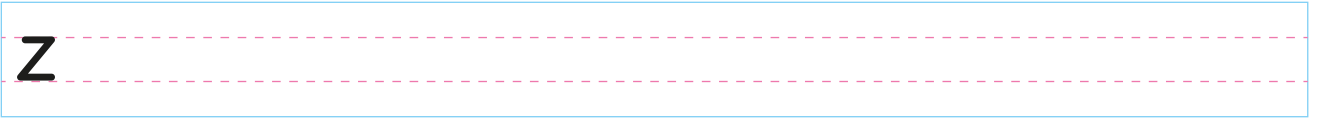
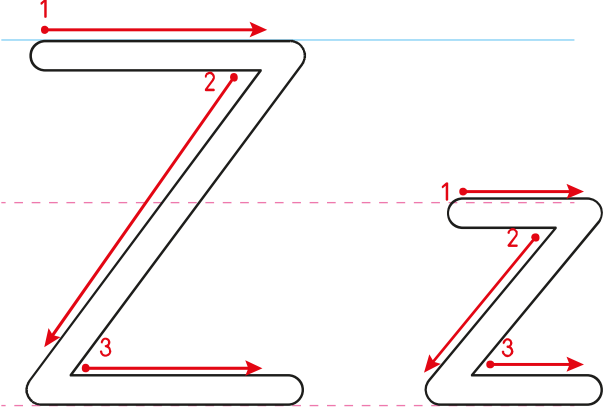



Okuyalım, yazalım.

e z

ez

z e

ze

a z

az

z a

za

i z

iz

z i

zi

o z

oz

z o

zo

ez me

ezme

Ze ki

Zeki

Zeki ezme yer.

Az ra

Azra

ka za

kaza

Azra kaza oldu.

İz mir

İzmir

Zi ya

Ziya

Ziya İzmirli.

O zan

Ozan

zo r

zor

Ozan soru zor.



u z uz z u zu

ü z üz z ü zü

ö z öz z ö zö

ı z iz z ı zi

uz man uzman ku zu kuzu

Kuzu uzmanı bul.

yü z yüz ü züm üzüm

Yüz üzüm yeme.

Öz lem Özlem sö z söz

Özlem söz söyle.

ba zı bazı ya zı yazı

Bazı yazılar kötü.



☞ Kelimeleri okuyalım, yazalım.

buz

tuz

muz

biz

toz

diz

yaz

naz

kaz

Arzu

imza

yazı

Ziya

Remzi

Nazan

beyaz

biraz

sözlük

kırmızı

bilezik

ziyaret

mızıka

mezura



☞ Karışık hecelerden kelimeler oluşturup yazalım.

ya maz ra ▶

rum zu Er ▶

De li niz ▶

zel be ye ▶

lak za ko ▶

man ra za ▶

kir zi mi ▶

ka mi zi ▶

me ra zu ▶



☞ Cümleleri görsellerin adlarıyla tamamlayalım. Cümleleri okuyalım.



Teyzem sekiz yedi.



Yılmaz rakamını yazar.



Uzayda bir kaydı.



..... müzikle dans etti.



Nazan koluna taktı.



O zaman alalım.



👉 Aynı rakamla eşleşen kelimelerle cümle oluşturup yazalım.

1 Teyzem	2 Beyza'yı	3 müzik
4 kazak	3 Ozan	2 etti
5 denizde	4 örüyor	1 oturuyor
2 Zerrin	5 yüzer	4 beyaz
5 mi	5 zebra	4 Suzan
3 dinliyor	1 Denizli'de	2 ziyaret

1

2

3

4

5



👉 Metni okuyalım. Aşağıya yazalım.

ZEYTİN İLE ÜZÜM

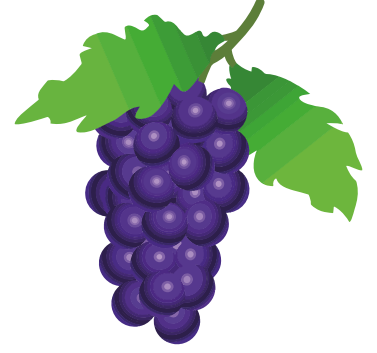

Teyzem bana zeytin aldı.

Bir de üzüm aldı.

Zeytinleri birer birer yedim.

Üzümü Azra'ya ayırdım.

Üzümü birlikte yeriz.



Empty box for writing the first line of the text.

Empty box for writing the second line of the text.

Empty box for writing the third line of the text.

Empty box for writing the fourth line of the text.

Empty box for writing the fifth line of the text.

Empty box for writing the sixth line of the text.



👉 Cümleleri okuyalım. Soruları cevaplayalım.

Arzu zile uzun bastı.

Zile nasıl bastı?

Kim zile bastı?

Ozan özür dilemedi.

Kim özür dilemedi?

Ozan ne dilemedi?

Ezo taze balık yer.

Nasıl balık yer?

Kim balık yer?



☞ Cümleleri okuyalım. Soruları cevaplayalım.

Azra'dan izin aldı.

Kimden izin aldı?



Azra'dan ne aldı?



Rozeti terziye buldu.

Neyi terziye buldu?



Rozeti nerede buldu?



Aziz sözünü tuttu.

Kim sözünü tuttu?



Aziz ne tuttu?



☞ Metini okuyalım. İstedığımız sonu işaretleyelim.

Biz temiz insanlarız. Elimizi yıkarız.
Yüzümüzü yıkarız. Odamızı temizleriz.

Yerleri tozlu bırakmayız.

Tozları bezle sileriz.

Teyzem sebze aldı. Sebzeleri yıkadı.
Biraz kirazla muz da aldı. Muzları
yıkamadı.

Kirazları yıkadı. Onları biz yedik.

Sebzeleri tuzladı. Yemekte kullandı.

Annem bize yumak aldı. Yumaklar
sekiz tane. Bize kazak ördü. Benimki
kırmızı.

Ziya'nın ise beyaz.

Kırmızı kazak tatlı oldu.

👉 Adında "ç" sesi bulunan varlıkları boyayalım.

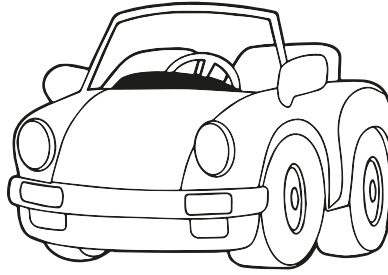
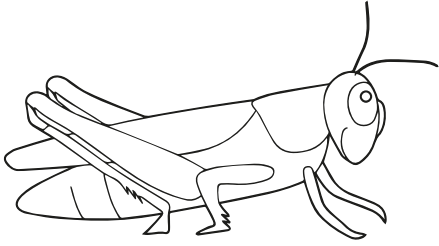
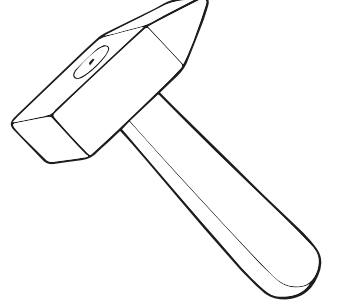
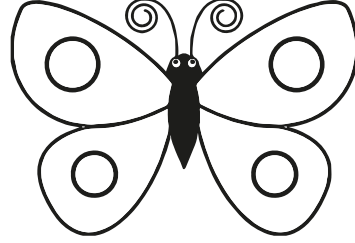
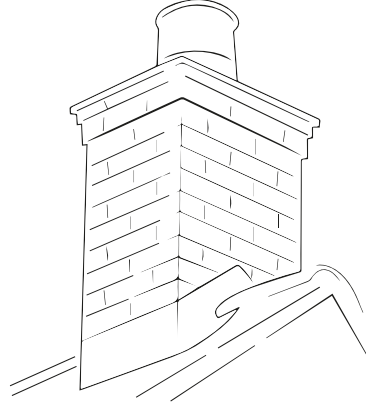
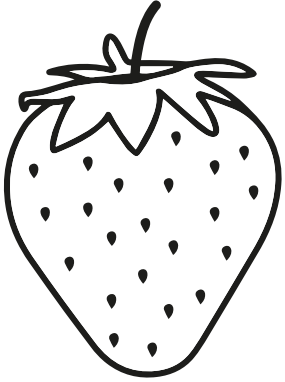

👉 "ç" sesi ile başlayan varlıkları işaretleyelim.

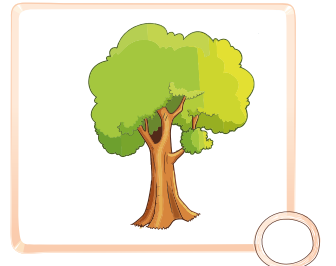
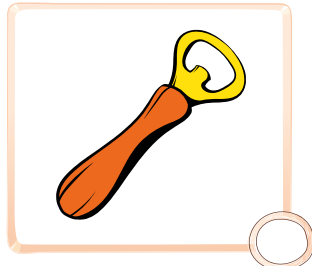
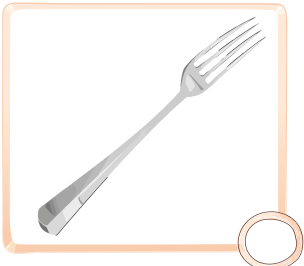
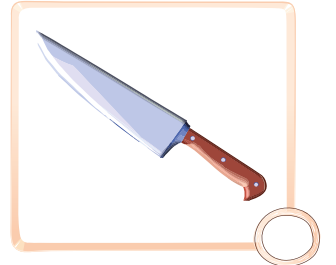
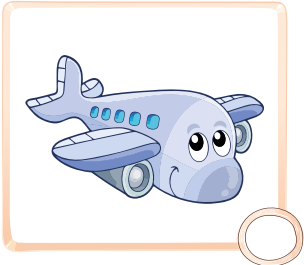
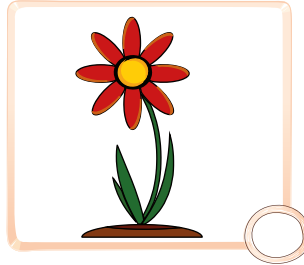

👉 Büyük "Ç" harfinin yazılış yönüne dikkat edelim. İçinden kalemimizle geçelim.

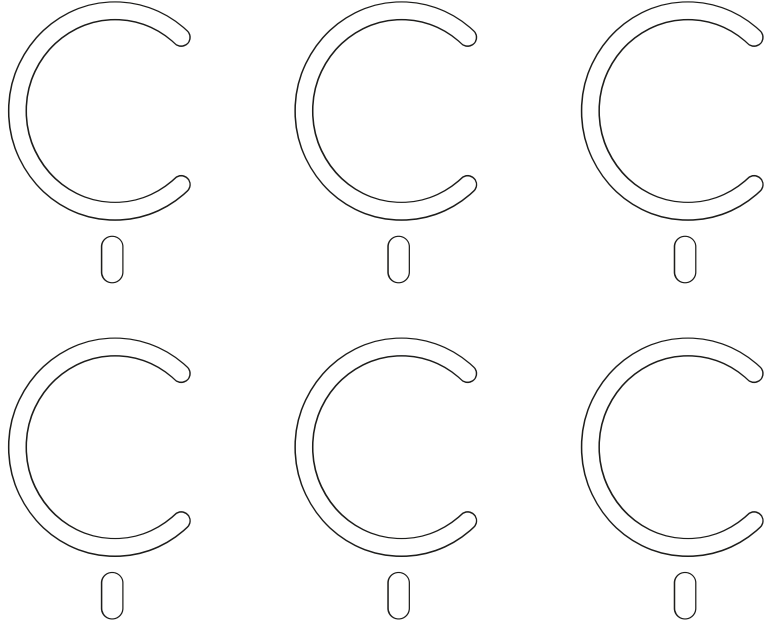
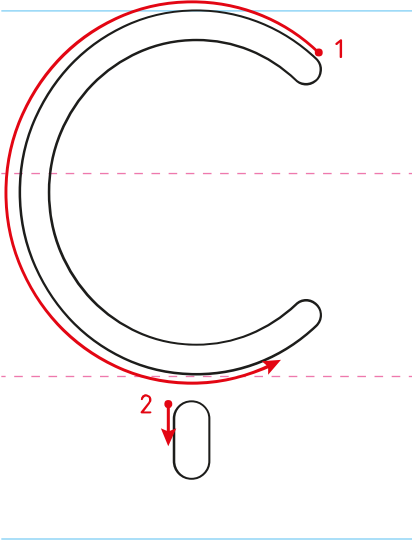

👉 "Ç" harfinin yazılı olduğu balonları boyayalım.

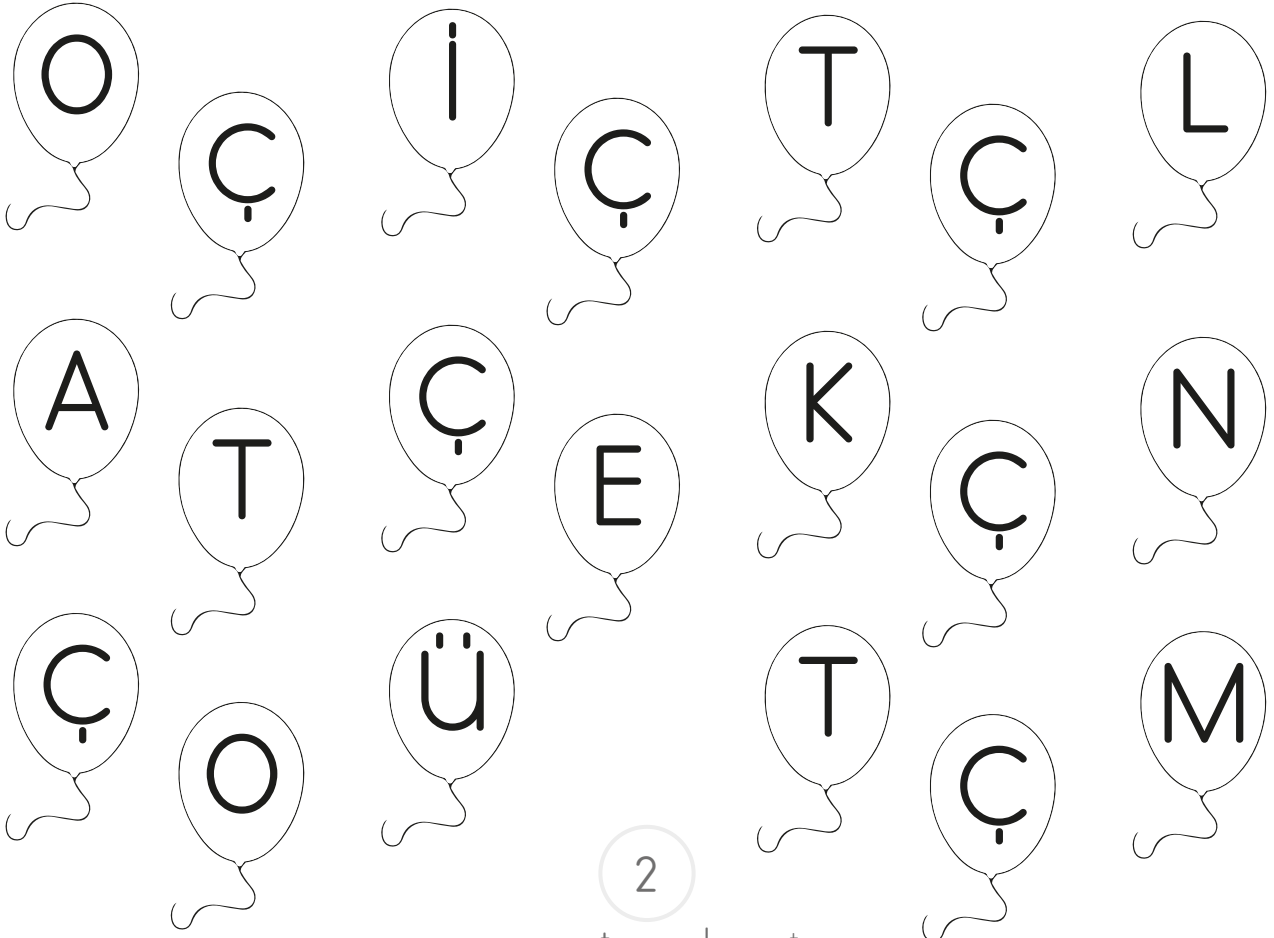

Yönergeleri uygulayalım.

• "Ç" harfini boyayalım.

• "Ç" harflerini bulup yuvarlak içine alalım.

• Noktaları birleştirelim.

Yazma yönüne dikkat ederek "Ç" harfini yazalım.



☞ "Ç" harfini yazalım.

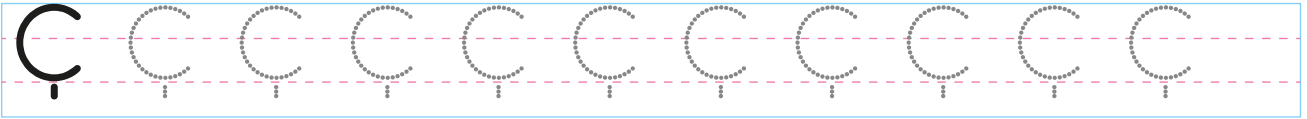
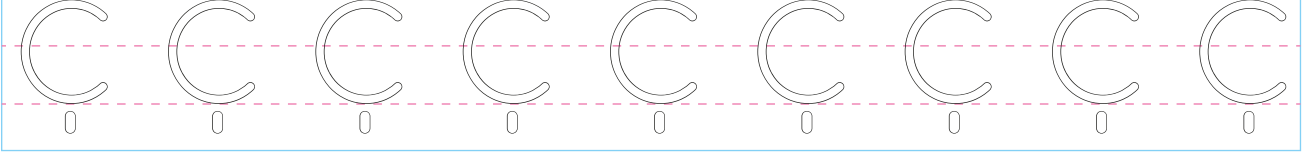



☞ Küçük "ç" harfinin yazılış yönüne dikkat edelim. İçinden kalemimizle geçelim.

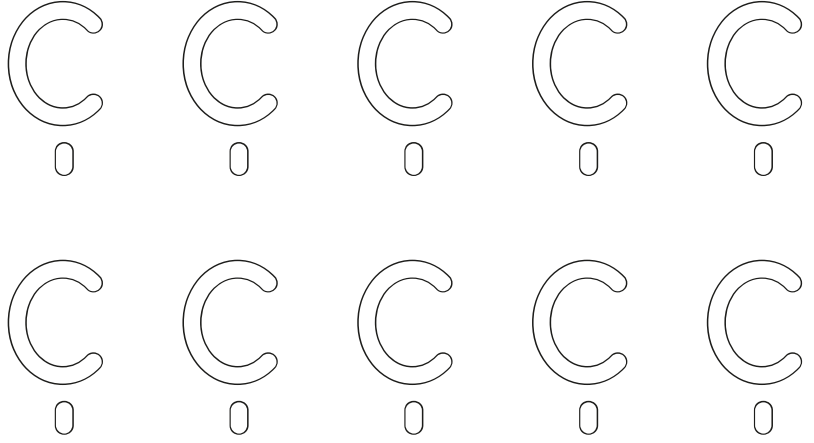
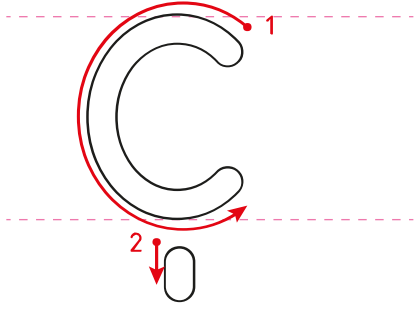

☞ "ç" harfinin yazılı olduğu yıldızları boyayalım.

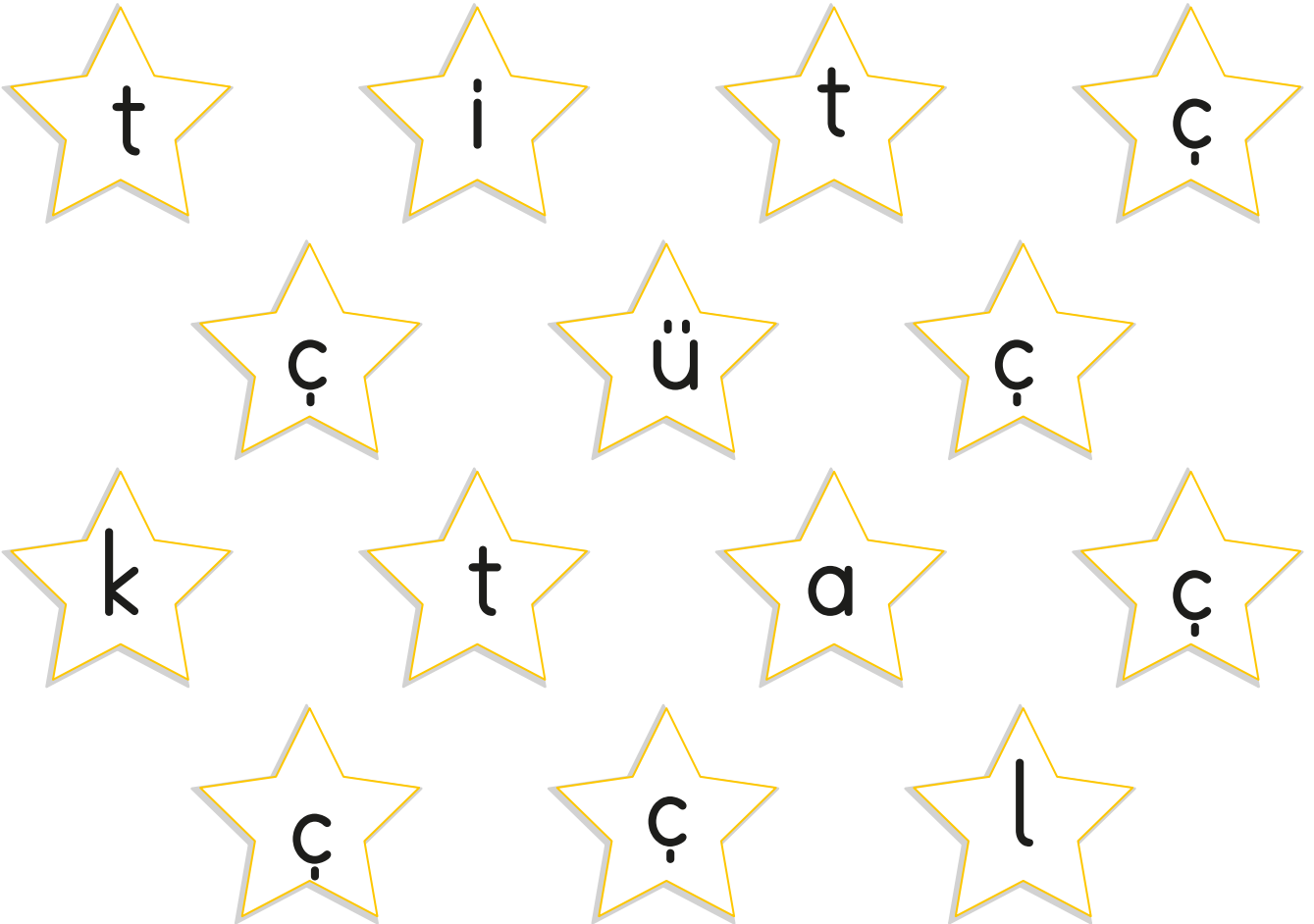

Yönergeleri uygulayalım.

- "ç" harfini boyayalım.

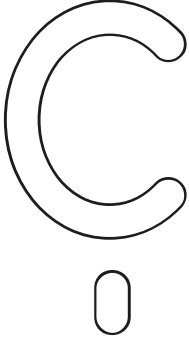

- "ç" harflerini bulup yuvarlak içine alalım.

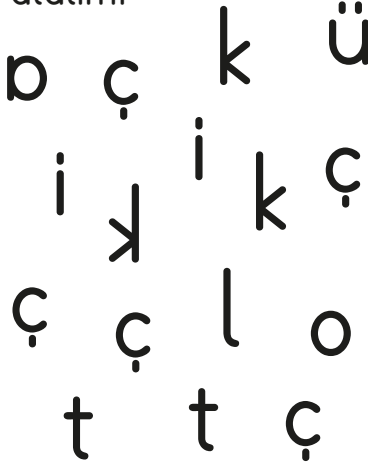

- Noktaları birleştirelim.

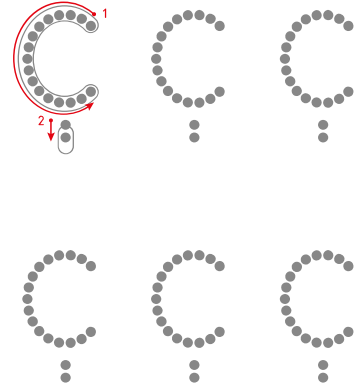

Yazma yönlerine dikkat ederek "ç" harfini yazalım.

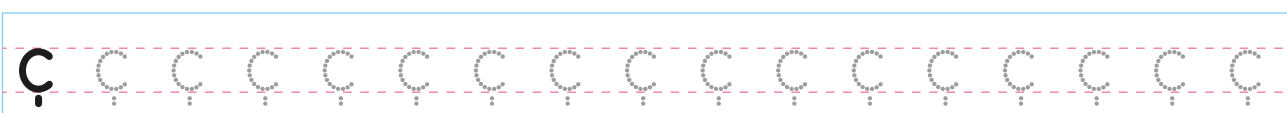
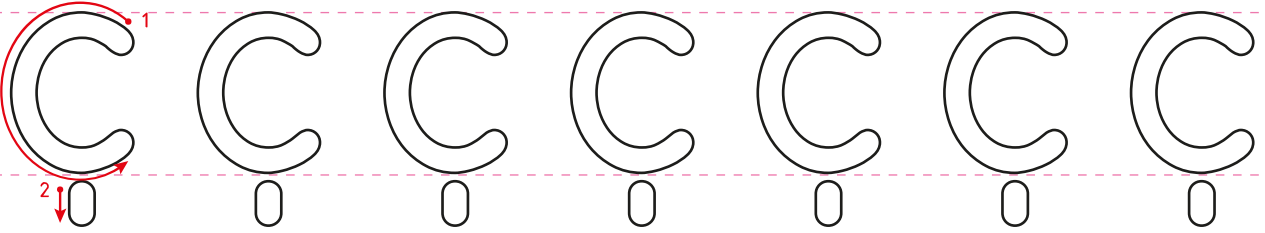



☞ "ç" harfini yazalım.

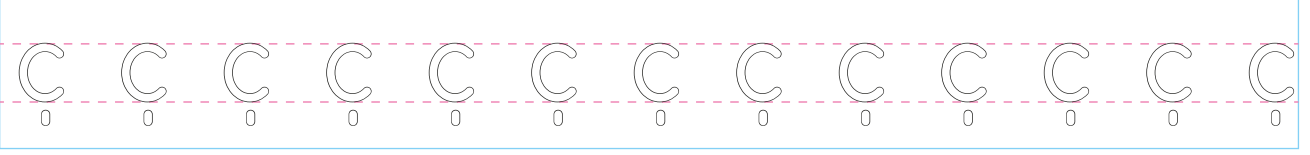



👉 Büyük "Ç" ve küçük "ç" harfini yazalım.

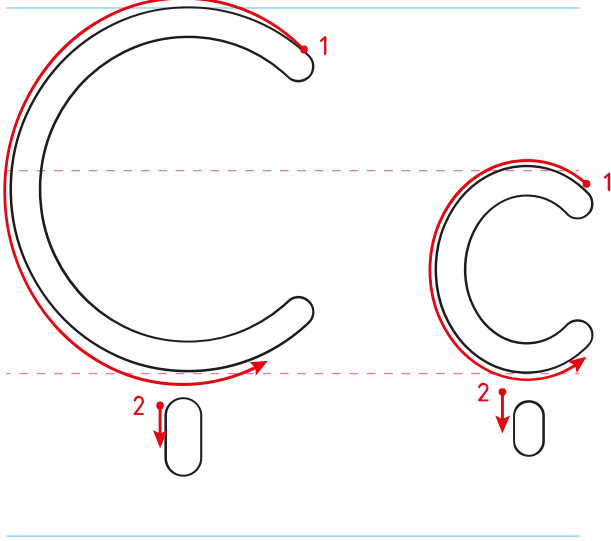



Okuyalım, yazalım.

e	ç	eç	ç	e	çe
a	ç	aç	ç	a	ça
i	ç	iç	ç	i	çi
o	ç	oç	ç	o	ço

ç	rez	çerez	Ç	tin	Çetin
---	-----	-------	---	-----	-------

Çetin çerez yer.

aç	ma	açma	ça	dır	çadır
----	----	------	----	-----	-------

Çadırı açma.

iç	ti	içti	ke	çi	keçi
----	----	------	----	----	------

Keçi su içti.

ko	ç	koç	ço	ban	çoban
----	---	-----	----	-----	-------

Çoban koçu tuttu.



u	ç	uç	ç	u	çu
ü	ç	üç	ç	ü	çü
ö	ç	öç	ç	ö	çö
ı	ç	ıç	ç	ı	çı

uç	tu	uçtu	çu	kur	çukur
----	----	------	----	-----	-------

Arı çukura uçtu.

üç	lü	üçlü	çü	rük	çürük
----	----	------	----	-----	-------

Üçlü kiraz çürük.

çö	l	çöl	çö	rek	çörek
----	---	-----	----	-----	-------

Çölde çörek yedik.

çı	ta	çıtta	Çı	nar	Çınar
----	----	-------	----	-----	-------

Çınar çıtta çaktı.



👉 Kelimeleri okuyalım, yazalım.

çam

Handwriting practice box for the word 'çam'.

çim

Handwriting practice box for the word 'çim'.

çöl

Handwriting practice box for the word 'çöl'.

çay

Handwriting practice box for the word 'çay'.

çek

Handwriting practice box for the word 'çek'.

çatı

Handwriting practice box for the word 'çatı'.

keçi

Handwriting practice box for the word 'keçi'.

uçak

Handwriting practice box for the word 'uçak'.

çene

Handwriting practice box for the word 'çene'.

çiçek

Handwriting practice box for the word 'çiçek'.

çadır

Handwriting practice box for the word 'çadır'.

çekiç

Handwriting practice box for the word 'çekiç'.

çanta

Handwriting practice box for the word 'çanta'.

sonuç

Handwriting practice box for the word 'sonuç'.

çoban

Handwriting practice box for the word 'çoban'.

çörek

Handwriting practice box for the word 'çörek'.

serçe

Handwriting practice box for the word 'serçe'.

Türkçe

Handwriting practice box for the word 'Türkçe'.

çardak

Handwriting practice box for the word 'çardak'.

reçete

Handwriting practice box for the word 'reçete'.

çikolata

Handwriting practice box for the word 'çikolata'.

Açelya

Handwriting practice box for the word 'Açelya'.

uçurtma

Handwriting practice box for the word 'uçurtma'.



☞ Karışık hecelerden kelimeler oluşturup yazalım.

dan çay lık

çe dek kir

bik len çit

u ma çurt

çek çi çi

çor ya ba

çi çöm lek

te çe re

çi ke ler



☞ Karışık kelimelerden cümleler oluşturup yazalım.

Yalçın

çay

demledi

Çişi'e

inatçı

keçiler

olur

çok

çamur

Selçuk

oldu

maçta

çilek

aldı

Ayça

reçeli

Seçkin

yedi

reçeli

çilek

uçtu

camdan

küçük

serçe



👉 Cümleleri görseli ile eşleştirelim.

Seçil saçını kesti.

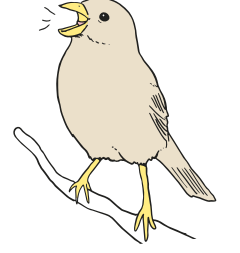

Doktor reçete yazdı.



Minik serçe ötüyor.



Ayça süt içiyor.

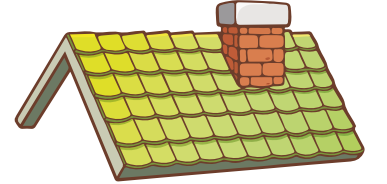

Çizme çok çamurlu.



Çınarlar çatıya çıktı.





👉 Metni okuyalım. Aşağıya yazalım.

ÇİÇEK

Çetin annesine çiçek aldı.

Ayça çiçekleri saksıya koydu.

İçine biraz da su ekledi.

Çiçekler mis kokular saldı.

Çetin ile Ayça mutlu oldu.



Empty box for writing the first line of the text.

Empty box for writing the second line of the text.

Empty box for writing the third line of the text.

Empty box for writing the fourth line of the text.

Empty box for writing the fifth line of the text.

Empty box for writing the sixth line of the text.



👉 Metini okuyalım. Soruları cevaplayalım.

YALÇIN

Yalçın okuldan döndü. Annesi çorba kaynattı. Yalçın çorba içti. Sonra yola çıktı. Babası çimleri biçiyordu. Yalçın da çim biçti. Elleri çamur oldu. Yalçın ellerini yıkadı.

1. Yalçın ne içti?

2. Yalçın nereye çıktı?

3. Babası ne biçiyordu?

4. Yalçın'ın ellerine ne oldu?



☞ Görseli verilen varlığın adını yazarak kelimeleri bulalım.

reç



3er

Ç



in

ç



ç



Aç

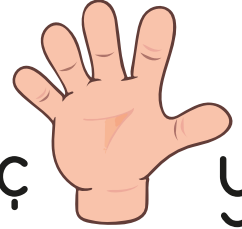

ya



çi



çü

çi



ç



ik



ça

Çi



ta

👉 Adında "g" sesi bulunan varlıkları boyayalım.

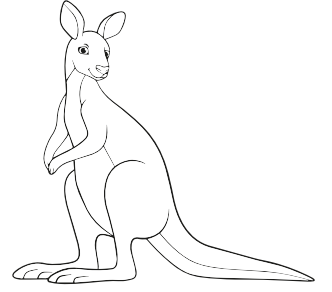
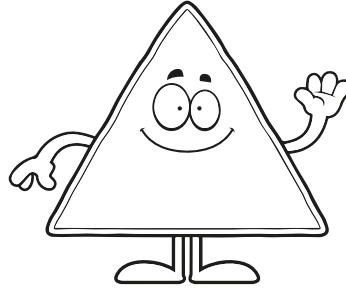
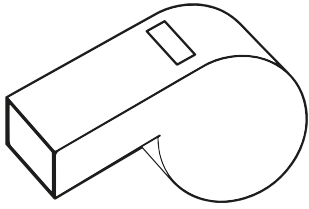
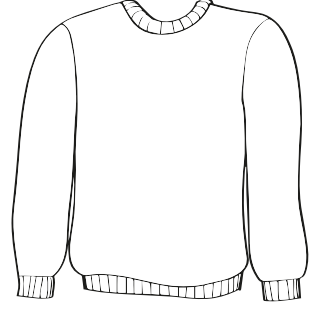
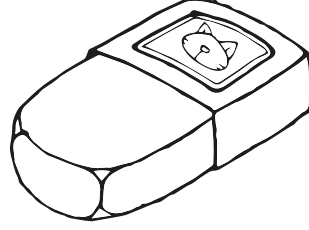
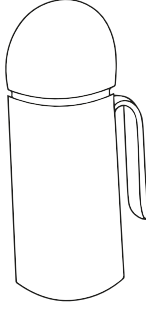
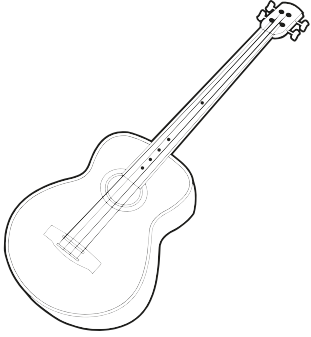

👉 "g" sesi ile başlayan varlıkları işaretleyelim.

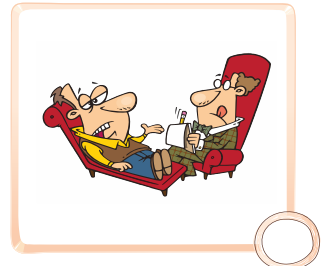
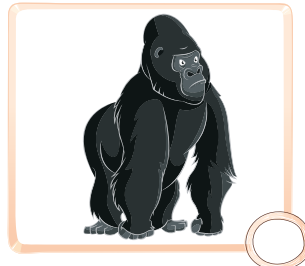
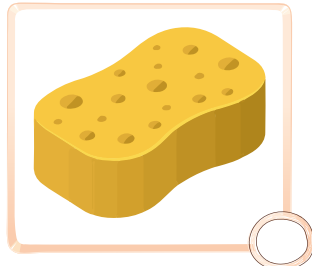
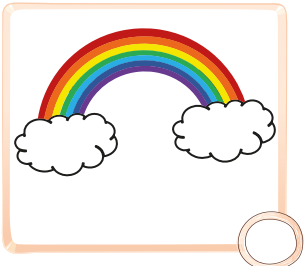
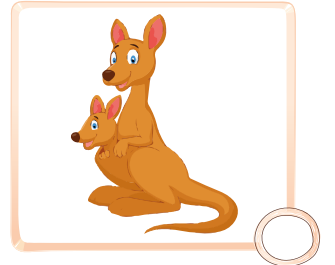
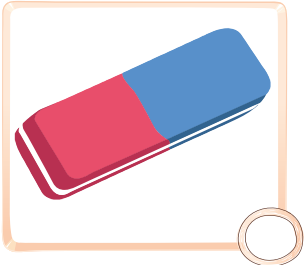
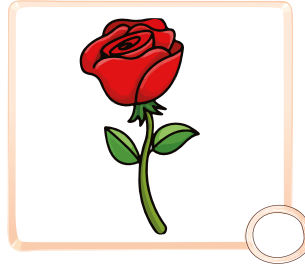
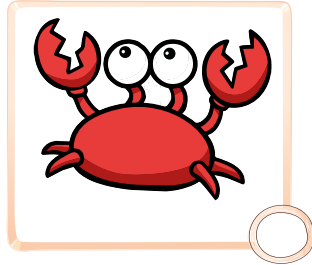
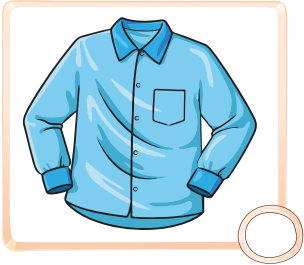

👉 Büyük "G" harfinin yazılış yönüne dikkat edelim. İçinden kalemimizle geçelim.

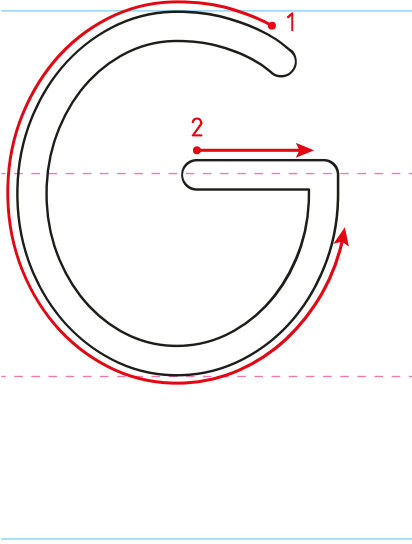

👉 "G" harfinin yazılı olduğu balonları boyayalım.

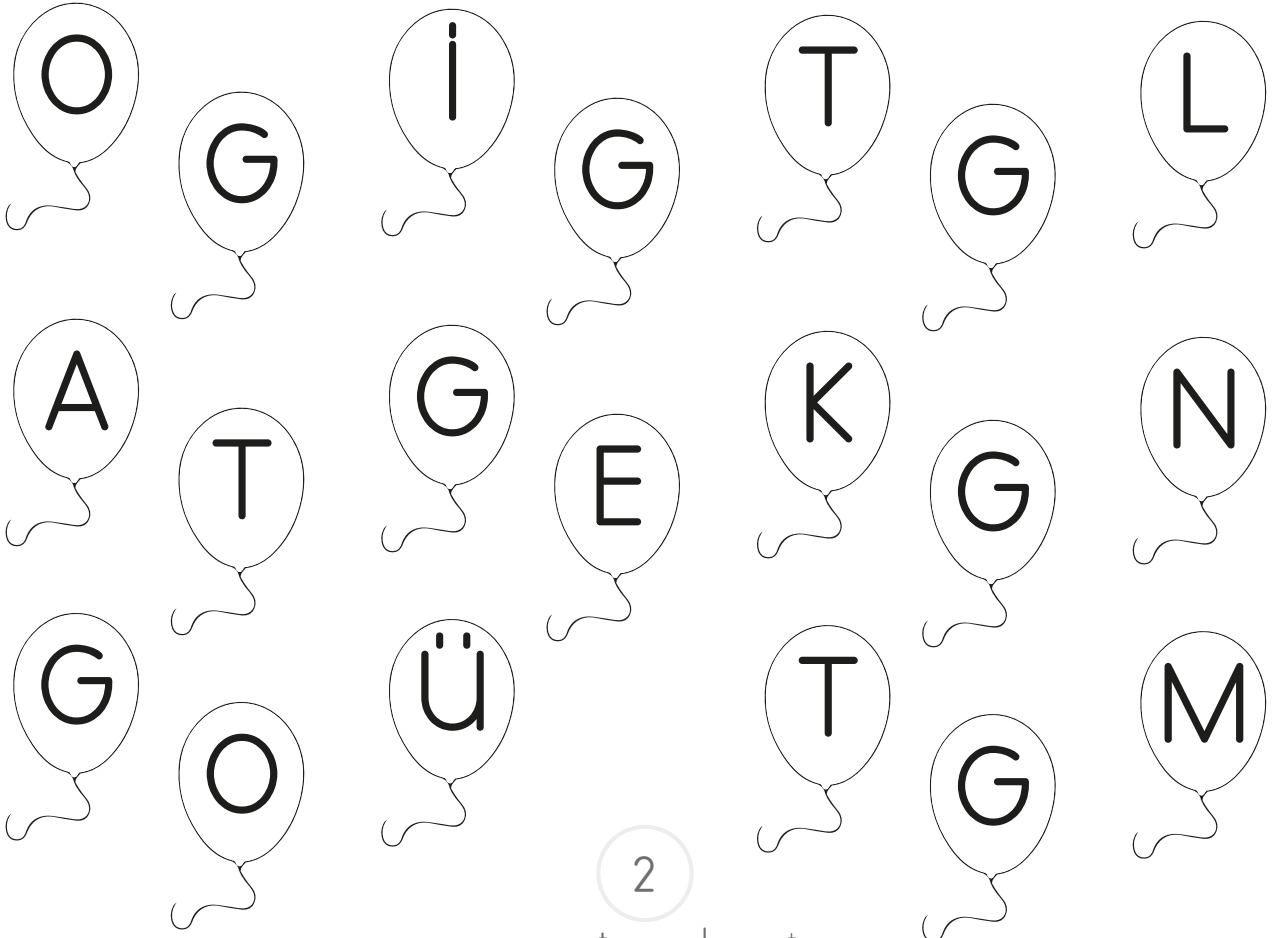

Yönergeleri uygulayalım.

- "G" harfini boyayalım.

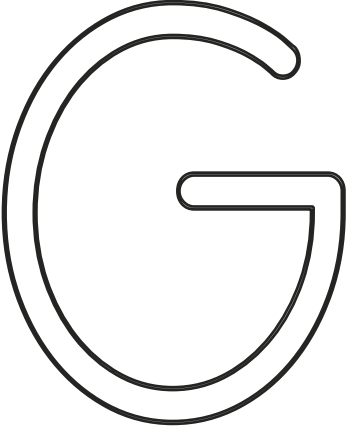

- "G" harflerini bulup yuvarlak içine alalım.

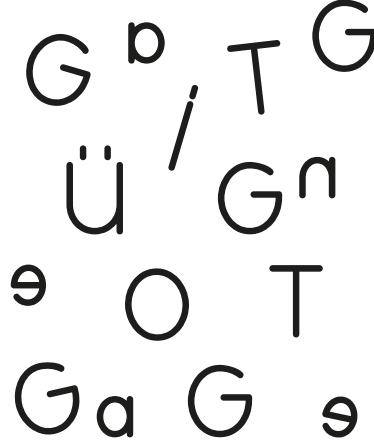

- Noktaları birleştirelim.

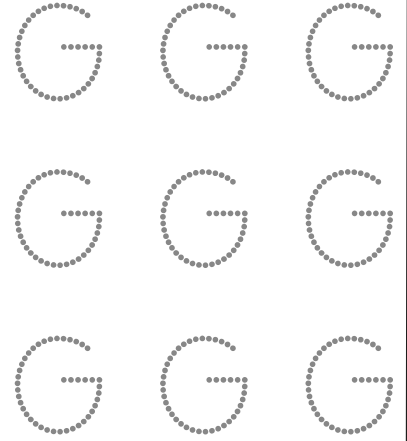

Yazma yönüne dikkat ederek "G" harfini yazalım.

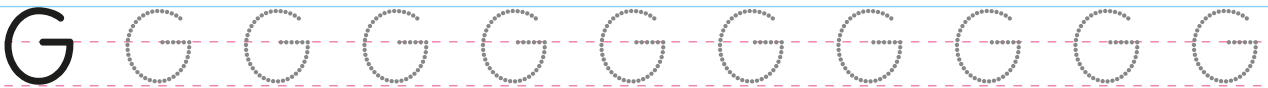
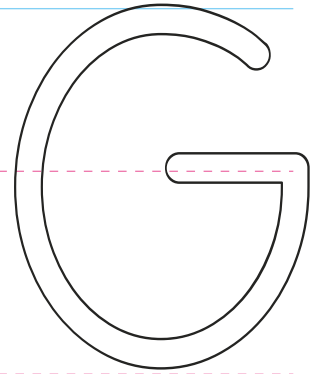
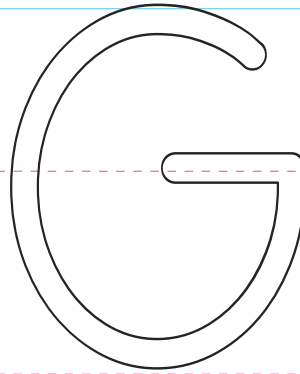
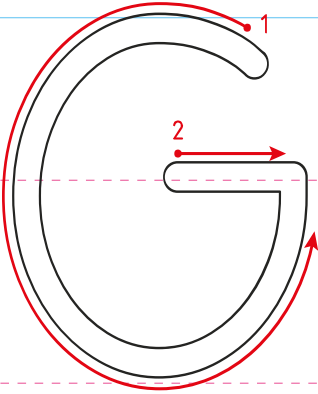



☞ "G" harfini yazalım.

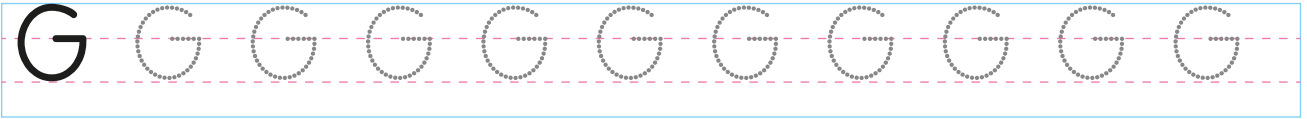



☞ Küçük "g" harfinin yazılış yönüne dikkat edelim. İçinden kalemimizle geçelim.

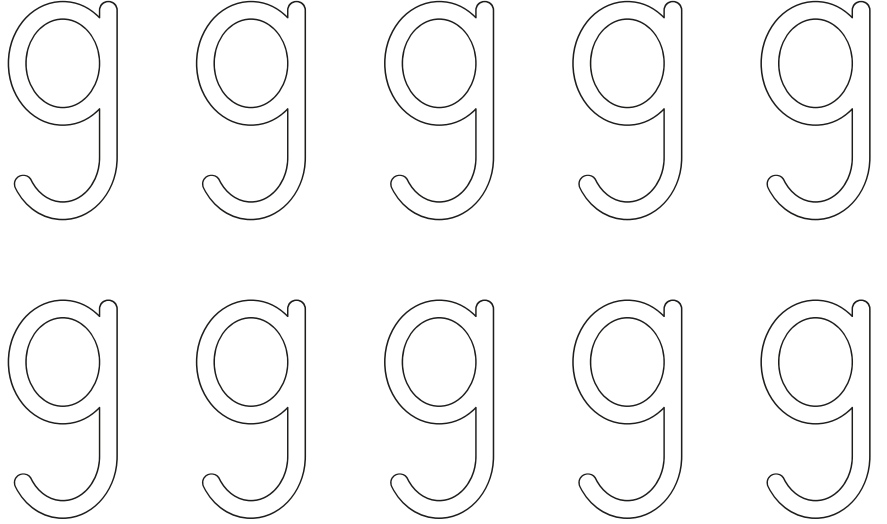
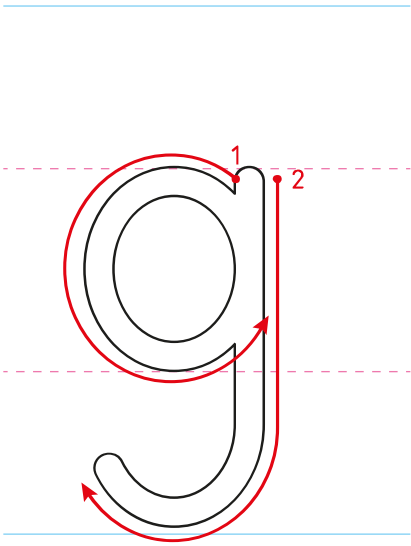

☞ "g" harfinin yazılı olduğu yıldızları boyayalım.



Yönergeleri uygulayalım.

• "g" harfini boyayalım.



• "g" harflerini bulup yuvarlak içine alalım.

b g k ü
i k g
g g l o
t t g

• Noktaları birleştirelim.

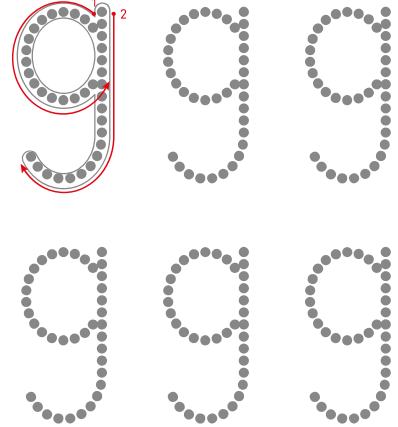

Yazma yönlerine dikkat ederek "g" harfini yazalım.

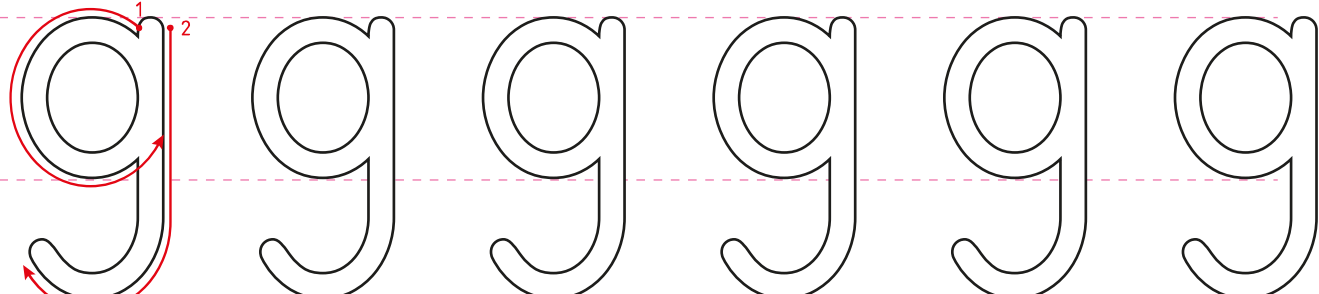



☞ "g" harfini yazalım.

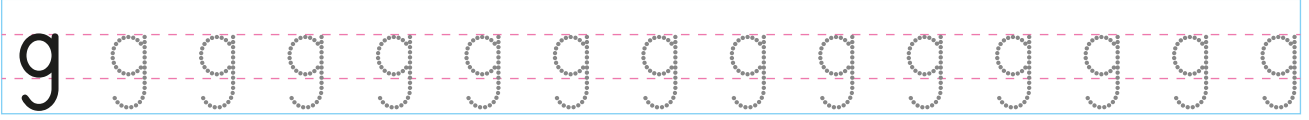
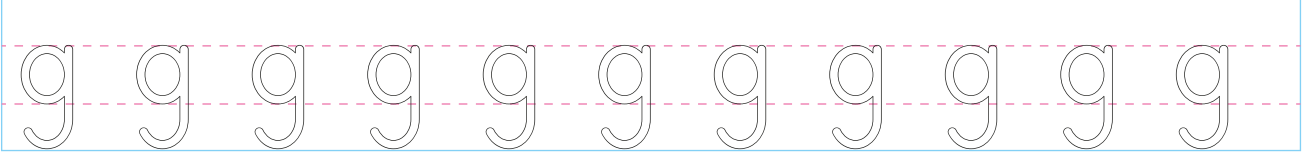



👉 Büyük "G" ve küçük "g" harfini yazalım.

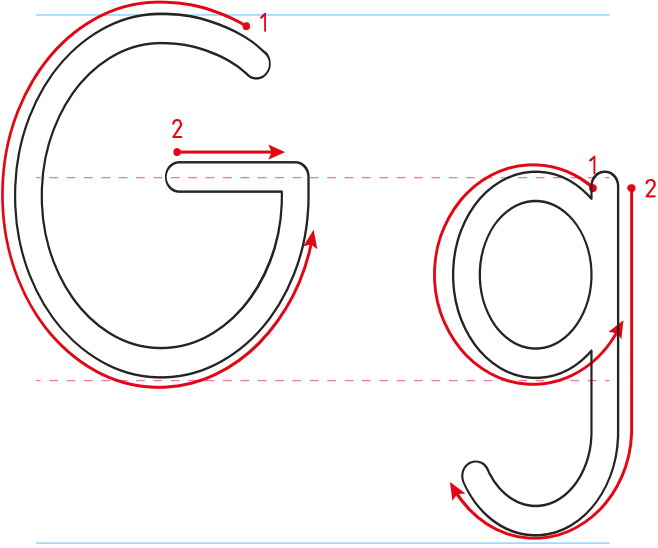



Okuyalım, yazalım.

e g eg g e ge

a g ag g a ga

i g ig g i gi

o g og g o go

E ge Ege ge mi gemi

Ege'ye gemi indi.

ga zi gazi Gam ze Gamze

Gamze'nin babası gazi oldu.

Gi zem Gizem der gi dergi

Gizem dergi okur.

lo go logo kar go kargo

Bize kargo geldi.



Okuyalım, yazalım.

u	g	ug	g	u	gu
ü	g	üg	g	ü	gü
ö	g	ög	g	ö	gö
ı	g	ig	g	ı	gı

gu	n	gun	uy	gun	uygun
----	---	-----	----	-----	-------

Bu bize uygun.

gü	zel	güzel	gör	gü	görgü
----	-----	-------	-----	----	-------

Görgülü olmak çok güzel.

gö	z	göz	göz	lem	gözlem
----	---	-----	-----	-----	--------

Giray gözlemledi.

say	gı	saygı	al	gı	algı
-----	----	-------	----	----	------

Saygı önemli.



👉 Kelimeleri okuyalım, yazalım.

geç

Handwriting practice box for the word "geç" with a yellow highlighted area and dashed lines.

göl

Handwriting practice box for the word "göl" with a yellow highlighted area and dashed lines.

gül

Handwriting practice box for the word "gül" with a yellow highlighted area and dashed lines.

göz

Handwriting practice box for the word "göz" with a yellow highlighted area and dashed lines.

güç

Handwriting practice box for the word "güç" with a yellow highlighted area and dashed lines.

Ege

Handwriting practice box for the word "Ege" with a yellow highlighted area and dashed lines.

Gaye

Handwriting practice box for the word "Gaye" with a yellow highlighted area and dashed lines.

örgü

Handwriting practice box for the word "örgü" with a yellow highlighted area and dashed lines.

bilgi

Handwriting practice box for the word "bilgi" with a yellow highlighted area and dashed lines.

karga

Handwriting practice box for the word "karga" with a yellow highlighted area and dashed lines.

güney

Handwriting practice box for the word "güney" with a yellow highlighted area and dashed lines.

geyik

Handwriting practice box for the word "geyik" with a yellow highlighted area and dashed lines.

gazoz

Handwriting practice box for the word "gazoz" with a yellow highlighted area and dashed lines.

Güler

Handwriting practice box for the word "Güler" with a yellow highlighted area and dashed lines.

Gönül

Handwriting practice box for the word "Gönül" with a yellow highlighted area and dashed lines.

saygı

Handwriting practice box for the word "saygı" with a yellow highlighted area and dashed lines.

geçit

Handwriting practice box for the word "geçit" with a yellow highlighted area and dashed lines.

Giresun

Handwriting practice box for the word "Giresun" with a yellow highlighted area and dashed lines.

gazete

Handwriting practice box for the word "gazete" with a yellow highlighted area and dashed lines.

bilgisayar

Handwriting practice box for the word "bilgisayar" with a yellow highlighted area and dashed lines.

süpürge

Handwriting practice box for the word "süpürge" with a yellow highlighted area and dashed lines.

sünger

Handwriting practice box for the word "sünger" with a yellow highlighted area and dashed lines.

gözlük

Handwriting practice box for the word "gözlük" with a yellow highlighted area and dashed lines.



☞ Görseli verilen varlıkların adındaki eksik heceyi yazalım.



.....zete



kan.....ru



.....linlik

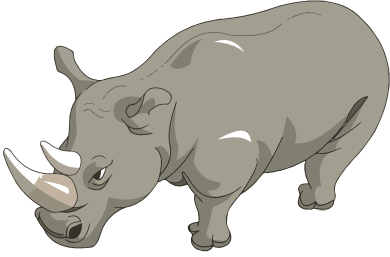

ger.....dan

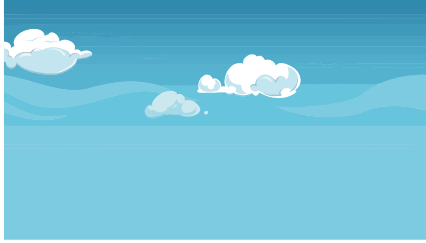

.....yüzü

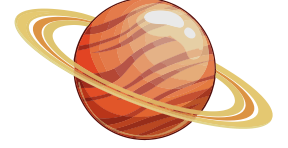

geze.....

☞ Noktalı yerleri uygun kelimelerle tamamlayalım.

grip gazete gol gül gözlük

➔ Babam anneme aldı.

➔ Özge gözüne taktı.

➔ Gamze oldu.

➔ Engin maçta uç attı.

➔ Gülçin okuyor.



👉 Cümleleri okuyalım. Okudukça balon boyayalım.

○ Gaye beni gördü, bana gülümsedi.

○ Engin gölde güzel güzel yüzdü.

○ Özgür marketten bulgur aldı.

○ Gizem göz doktoruna gitti.

○ Geçen gün Görkem'i gördüm.

○ Özge buraya geldi mi?

○ Ege gizli gizli bizi gözetliyor.

○ Tolga ile Rüzgâr dost oldu.

○ Gonca sergide giysi sattı.

○ Giray odada çekirge gördü.



👉 Aynı şeklin içindeki kelimelerle cümle oluşturalım. Cümleleri yazalım.

üçgen

karga

gri

geziye

giydi

kara

okuyor

Engin

Gizem

çizdi

gak

güzel

dedi

Gülsüm

buraya

giysiyi

gitti

Gülçin

Blank writing line with a dashed red line for the middle and a solid blue line for the bottom.

Blank writing line with a dashed red line for the middle and a solid blue line for the bottom.

Blank writing line with a dashed red line for the middle and a solid blue line for the bottom.

Blank writing line with a dashed red line for the middle and a solid blue line for the bottom.

Blank writing line with a dashed red line for the middle and a solid blue line for the bottom.



👉 Soruları kısaca cevaplayalım.

Ezgi gemi ile göle gitti.

• Kim gitti?

• Ne ile gitti?

• Nereye gitti?

Gül Gülay ile Gemlik'te oturur.

• Kim oturur?

• Kimle oturur?

• Nerede oturur?

Ege güzel güzel dergi okur.

• Kim okur?

• Nasıl okur?

• Ne okur?

Ogün bugün gözlük aldı.

• Kim aldı?

• Ne zaman aldı?

• Ne aldı?

👉 Metni okuyalım.

GAZETE

Gaye bakkala gitti.
Günlük gazete aldı.
Banka oturdu. Gözlük
taktı. Gazeteyi okudu.
Güzel güzel okudu.
Bilgisi arttı.

👉 Soruları cevaplayalım.

1. Gaye ne aldı?

2. Gaye ne taktı?

3. Gazeteyi nasıl
okudu?

👉 Metne uygun bir resim çizelim.



☞ Metni önce bir kez okuyalım. Sonra süre tutarak okuyalım. Bir dakikada kaç kelime okuduğumuzu tabloya yazalım.

Engin Giresun'a gitti. Karnı zil çalıyordu. Lokantaya girdi. Masaya oturdu. Garsona el etti. Garson ona menüyü uzattı. Engin bir gözleme istedi. Yanına da gazoz istedi. Bir süre sonra garson geldi. Engin'e su da getirdi. Engin karnını doyurdu. Sonra Giresun'u gezdi.

	Süre	Kelime Sayısı
1. Okuma	1 dakika kelime
2. Okuma	1 dakika kelime
3. Okuma	1 dakika kelime



MATEMATİK

1

2

3

4

5

6

7

8

-

9

0

÷

+

×

=

?



👉 Modellenen toplama işlemlerini yapalım.

$$\begin{array}{ccc} \begin{array}{|c|} \hline \bullet \bullet \\ \bullet \\ \hline \end{array} + \begin{array}{|c|} \hline \\ \hline \end{array} = \begin{array}{|c|} \hline \bullet \bullet \\ \bullet \\ \hline \end{array} \\ 3 + 0 = 3 \\ \dots + \dots = \dots \end{array}$$

$$\begin{array}{ccc} \begin{array}{|c|} \hline \\ \hline \end{array} + \begin{array}{|c|} \hline \bullet \bullet \\ \hline \end{array} = \begin{array}{|c|} \hline \bullet \bullet \\ \hline \end{array} \\ \dots + \dots = \dots \end{array}$$

$$\begin{array}{ccc} \begin{array}{|c|} \hline \bullet \bullet \\ \bullet \bullet \\ \hline \end{array} + \begin{array}{|c|} \hline \\ \hline \end{array} = \begin{array}{|c|} \hline \bullet \bullet \\ \bullet \bullet \\ \hline \end{array} \\ \dots + \dots = \dots \end{array}$$

$$\begin{array}{ccc} \begin{array}{|c|} \hline \\ \hline \end{array} + \begin{array}{|c|} \hline \bullet \\ \hline \end{array} = \begin{array}{|c|} \hline \bullet \\ \hline \end{array} \\ \dots + \dots = \dots \end{array}$$

$$\begin{array}{ccc} \begin{array}{|c|} \hline \\ \hline \end{array} + \begin{array}{|c|} \hline \bullet \bullet \\ \bullet \bullet \\ \hline \end{array} = \begin{array}{|c|} \hline \bullet \bullet \\ \bullet \bullet \\ \hline \end{array} \\ \dots + \dots = \dots \end{array}$$

$$\begin{array}{ccc} \begin{array}{|c|} \hline \bullet \bullet \bullet \bullet \\ \bullet \bullet \bullet \bullet \\ \hline \end{array} + \begin{array}{|c|} \hline \\ \hline \end{array} = \begin{array}{|c|} \hline \bullet \bullet \bullet \bullet \\ \bullet \bullet \bullet \bullet \\ \hline \end{array} \\ \dots + \dots = \dots \end{array}$$

$$\begin{array}{ccc} \begin{array}{|c|} \hline \bullet \bullet \bullet \bullet \\ \bullet \bullet \bullet \bullet \\ \hline \end{array} + \begin{array}{|c|} \hline \\ \hline \end{array} = \begin{array}{|c|} \hline \bullet \bullet \bullet \bullet \\ \bullet \bullet \bullet \bullet \\ \hline \end{array} \\ \dots + \dots = \dots \end{array}$$

$$\begin{array}{ccc} \begin{array}{|c|} \hline \\ \hline \end{array} + \begin{array}{|c|} \hline \bullet \bullet \\ \bullet \bullet \\ \hline \end{array} = \begin{array}{|c|} \hline \bullet \bullet \\ \bullet \bullet \\ \hline \end{array} \\ \dots + \dots = \dots \end{array}$$

$$\begin{array}{ccc} \begin{array}{|c|} \hline \bullet \bullet \bullet \bullet \\ \bullet \bullet \bullet \bullet \\ \hline \end{array} + \begin{array}{|c|} \hline \\ \hline \end{array} = \begin{array}{|c|} \hline \bullet \bullet \bullet \bullet \\ \bullet \bullet \bullet \bullet \\ \hline \end{array} \\ \dots + \dots = \dots \end{array}$$

$$\begin{array}{ccc} \begin{array}{|c|} \hline \bullet \bullet \bullet \bullet \\ \bullet \bullet \bullet \bullet \\ \hline \end{array} + \begin{array}{|c|} \hline \\ \hline \end{array} = \begin{array}{|c|} \hline \bullet \bullet \bullet \bullet \\ \bullet \bullet \bullet \bullet \\ \hline \end{array} \\ \dots + \dots = \dots \end{array}$$



☞ Aşağıdaki işlemleri yapalım.

$4 + 0 = \dots\dots\dots$

$0 + 7 = \dots\dots\dots$

$0 + 15 = \dots\dots\dots$

$12 + 0 = \dots\dots\dots$

$18 + 0 = \dots\dots\dots$

$1 + 0 = \dots\dots\dots$

$0 + 6 = \dots\dots\dots$

$0 + 17 = \dots\dots\dots$

$11 + 0 = \dots\dots\dots$

$0 + 10 = \dots\dots\dots$

$0 + 2 = \dots\dots\dots$

$5 + 0 = \dots\dots\dots$

$16 + 0 = \dots\dots\dots$

$0 + 14 = \dots\dots\dots$

$0 + 13 = \dots\dots\dots$

$3 + 0 = \dots\dots\dots$

$8 + 0 = \dots\dots\dots$

$0 + 9 = \dots\dots\dots$

$16 + 0 = \dots\dots\dots$

$0 + 19 = \dots\dots\dots$

İşlemleri yapalım. Sonuçlara ait parçaları bulup yapıştıralım. Oluşan görseli boyayalım.

$\begin{array}{r} 8 \\ + 0 \\ \hline \end{array}$	$\begin{array}{r} 5 \\ + 0 \\ \hline \end{array}$	$\begin{array}{r} 0 \\ + 3 \\ \hline \end{array}$
$\begin{array}{r} 6 \\ + 0 \\ \hline \end{array}$	$\begin{array}{r} 0 \\ + 1 \\ \hline \end{array}$	$\begin{array}{r} 9 \\ + 0 \\ \hline \end{array}$
$\begin{array}{r} 0 \\ + 2 \\ \hline \end{array}$	$\begin{array}{r} 4 \\ + 0 \\ \hline \end{array}$	$\begin{array}{r} 0 \\ + 7 \\ \hline \end{array}$

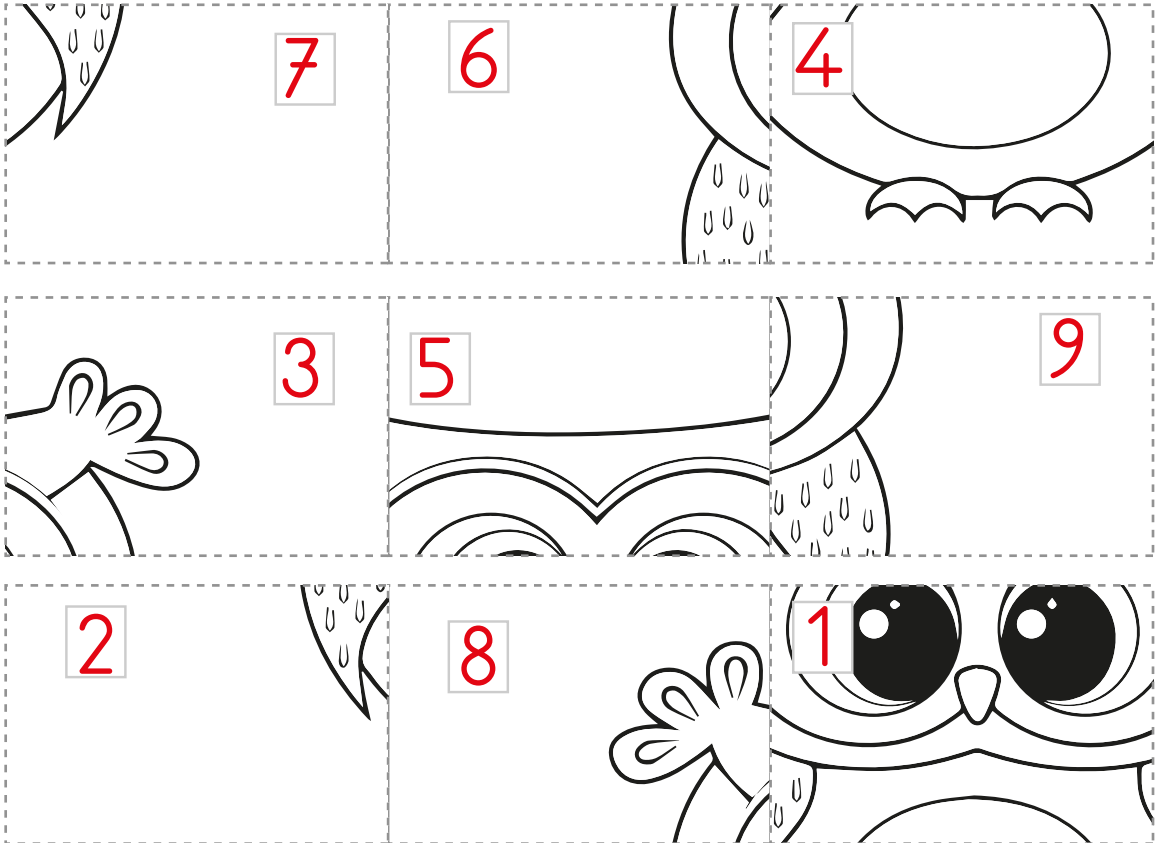

Aşağıdaki toplama işlemlerini yapalım.

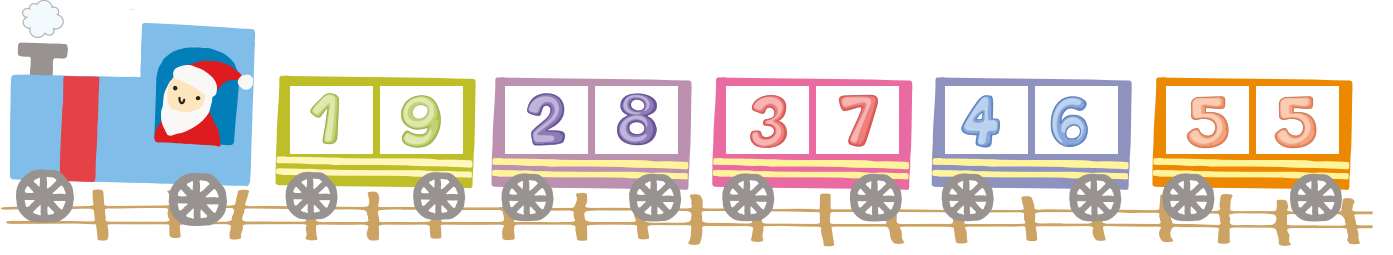

+	3
7	10

+	2
8	

+	3
7	

+	4
6	

+	5
5	

+	9
1	

10	0
10	0 = 10

6	4
	=

8	2
	=

7	3
	=

5	5
	=

2	8
	=



👉 Toplamı 10 olan balon ikililerini boyyalım.

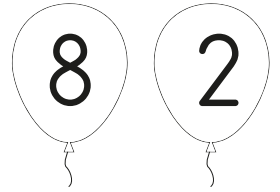
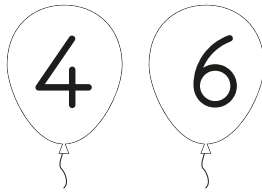
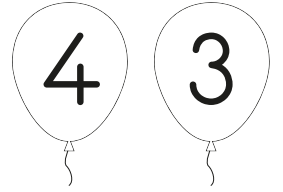
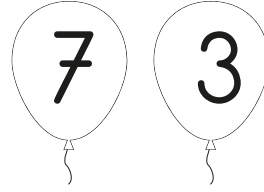
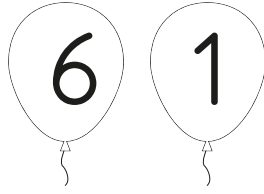
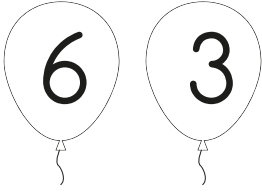
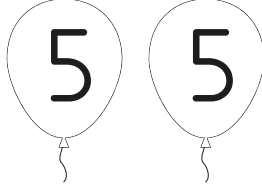
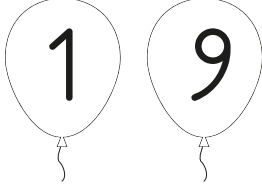

👉 Toplamı 10 olan sayılar yazalım.

+ = 10 + = 10 + = 10

+ = 10 + = 10 + = 10

+ = 10 + = 10 + = 10



👉 Toplamı 20 olan balon ikililerini boyyalım.

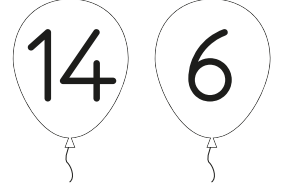
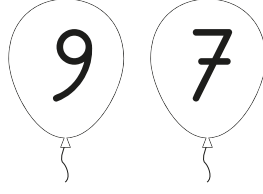
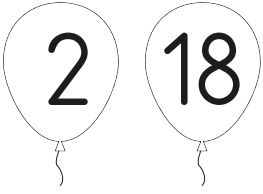
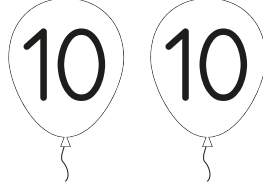
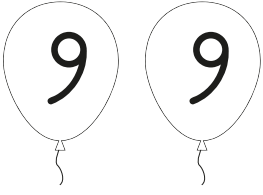
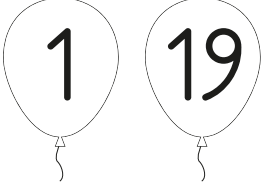

👉 Toplamı 20 olan sayılar yazalım.

+ = 20 + = 20 + = 20

+ = 20 + = 20 + = 20

+ = 20 + = 20 + = 20

+ = 20 + = 20 + = 20



👉 Toplama tablolarındaki işlemleri yapalım.

+	4	1
6	10	7
3	7	4

+	3	2
4		
8		

+	5	0
7		
3		

+	7	4
8		
10		

+	5	3
15		
8		

+	11	9
6		
5		

+	12	1
5		
11		

+	6	4
13		
6		

+	7	5
2		
13		

+	17	3
2		
15		

+	8	3
10		
1		

+	8	4
9		
2		

☞ Aşağıdaki toplama işlemlerini yapıp sonuçları boyayalım.

$$\begin{array}{r} 6 \\ + 2 \\ \hline \end{array}$$

8

7 8 9

$$\begin{array}{r} 4 \\ + 5 \\ \hline \end{array}$$

.....

5 7 9

$$\begin{array}{r} 3 \\ + 3 \\ \hline \end{array}$$

.....

4 5 6

$$\begin{array}{r} 4 \\ + 3 \\ \hline \end{array}$$

.....

6 7 8

$$\begin{array}{r} 8 \\ + 2 \\ \hline \end{array}$$

.....

8 9 10

$$\begin{array}{r} 7 \\ + 5 \\ \hline \end{array}$$

.....

10 11 12

$$\begin{array}{r} 6 \\ + 6 \\ \hline \end{array}$$

.....

11 12 13

$$\begin{array}{r} 5 \\ + 5 \\ \hline \end{array}$$

.....

10 11 12

$$\begin{array}{r} 13 \\ + 5 \\ \hline \end{array}$$

.....

16 17 18

$$\begin{array}{r} 11 \\ + 2 \\ \hline \end{array}$$

.....

12 13 14

$$\begin{array}{r} 14 \\ + 3 \\ \hline \end{array}$$

.....

15 16 17

$$\begin{array}{r} 10 \\ + 6 \\ \hline \end{array}$$

.....

16 17 18