

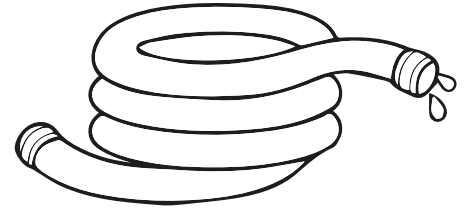

H, V VE Ğ SESİ ÇALIŞMALARI

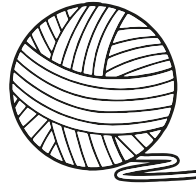

👉 Adında "h" sesi bulunan varlıkları boyayalım.

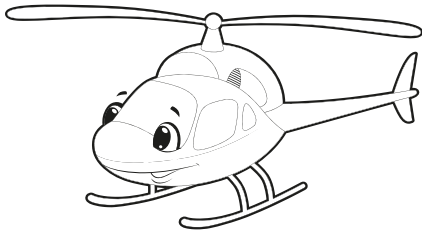
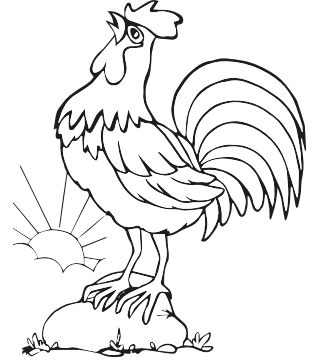

👉 "h" sesi ile başlayan varlıkları işaretleyelim.

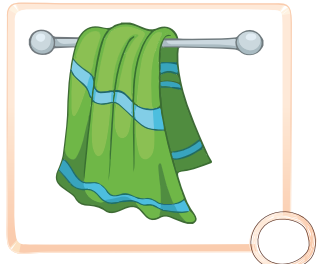
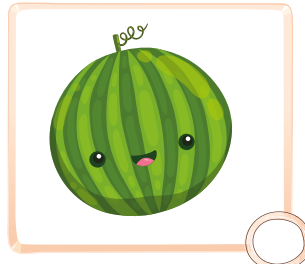
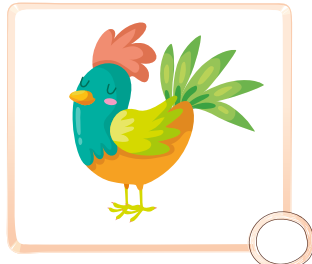
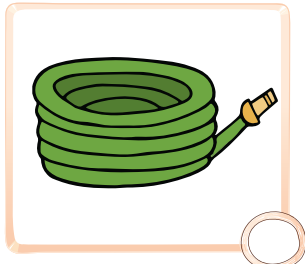
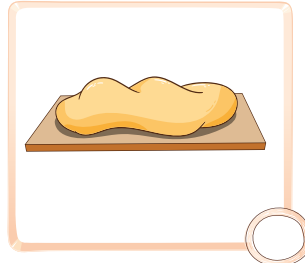
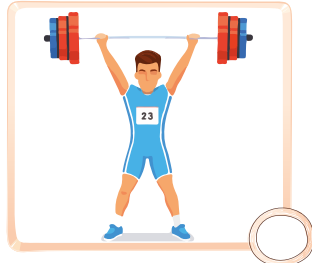
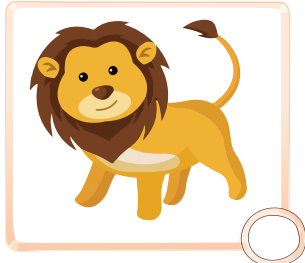
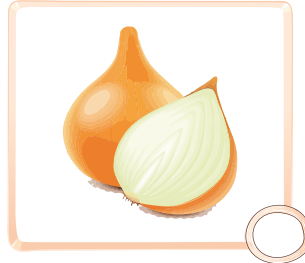
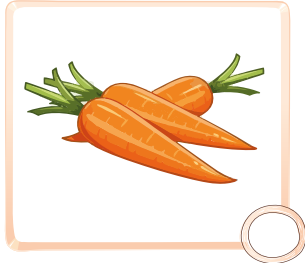



👉 Büyük "H" harfinin yazılış yönüne dikkat edelim. İçinden kalemimizle geçelim.

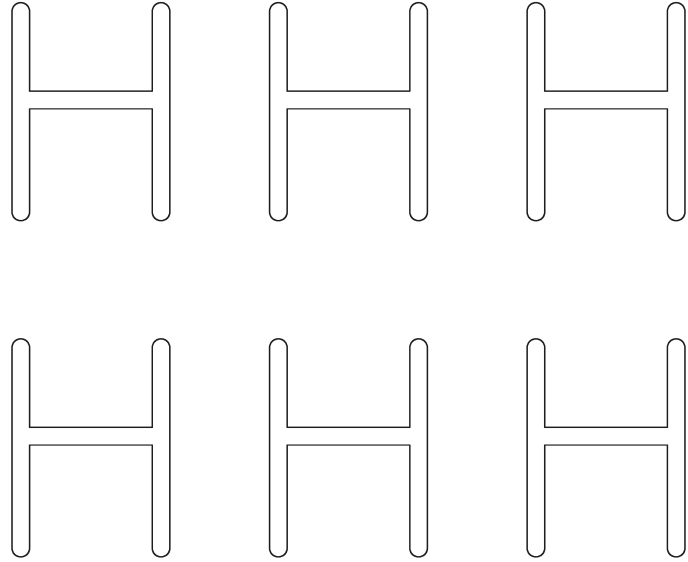
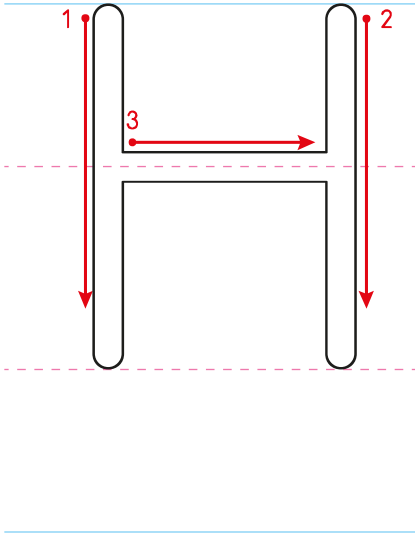

👉 "H" harfinin yazılı olduğu balonları boyayalım.

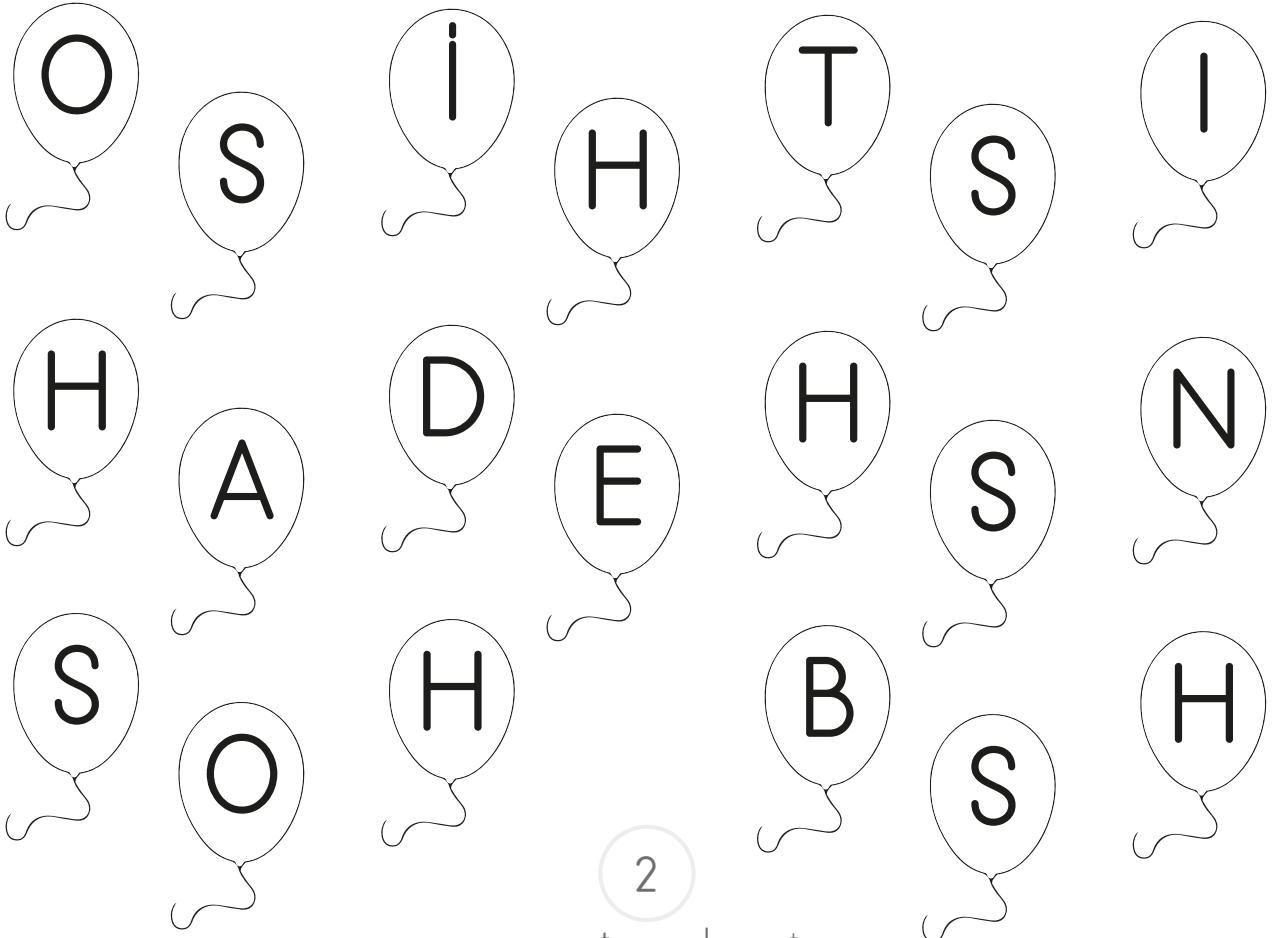

Yönergeleri uygulayalım.

• "H" harfini boyayalım.

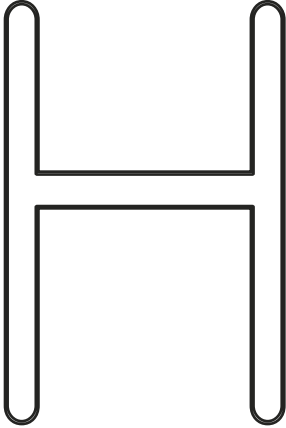

• "H" harflerini bulup yuvarlak içine alalım.



• Noktaları birleştirelim.

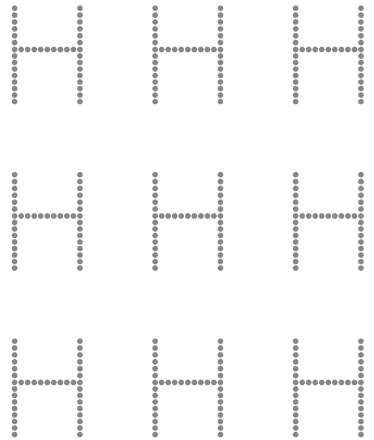

Yazma yönüne dikkat ederek "H" harfini yazalım.

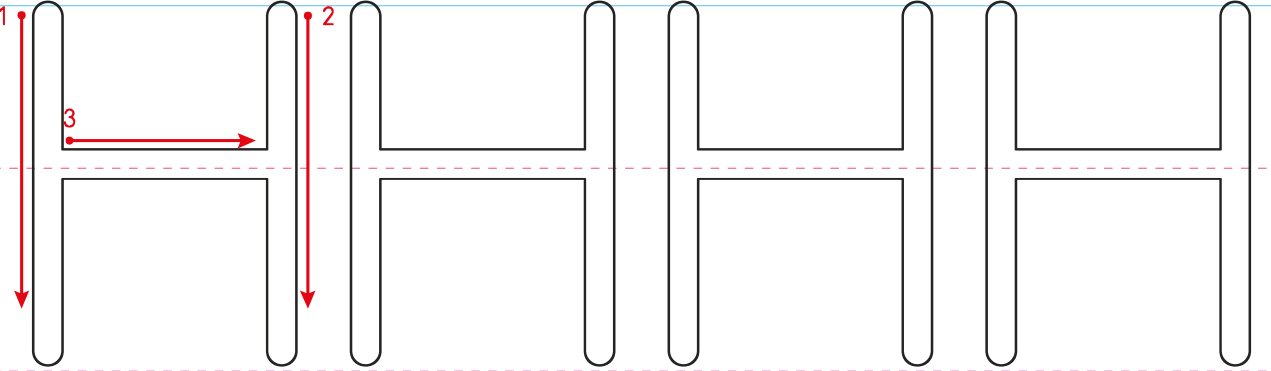



👉 "H" harfini yazalım.

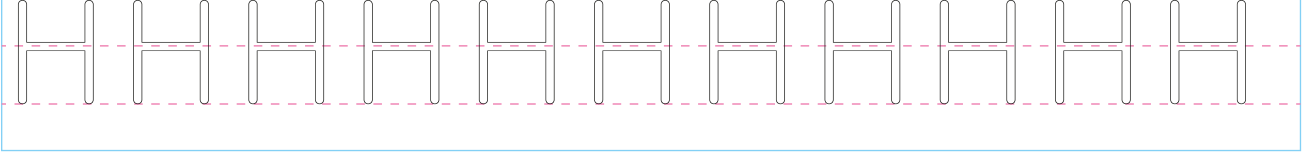



☞ Küçük "h" harfinin yazılış yönüne dikkat edelim. İçinden kalemimizle geçelim.

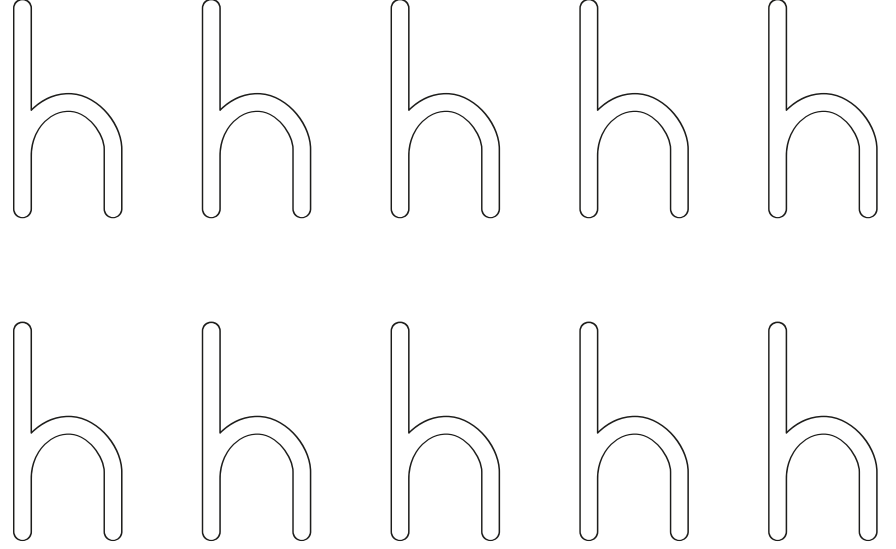
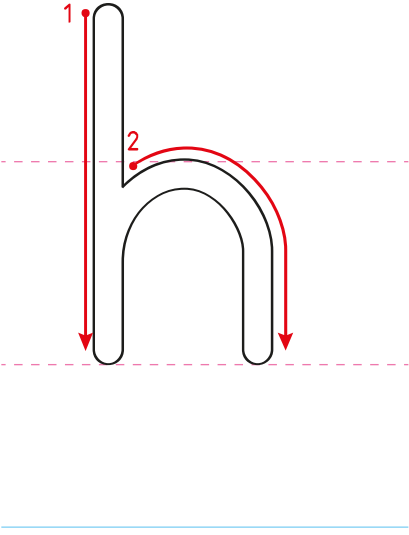

☞ "h" harfinin yazılı olduğu yıldızları boyayalım.



Yönergeleri uygulayalım.

- "h" harfini boyayalım.

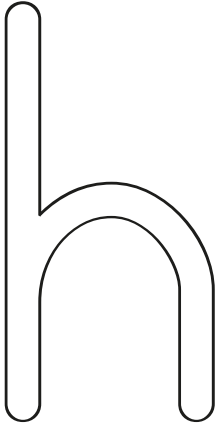

- "h" harflerini bulup yuvarlak içine alalım.

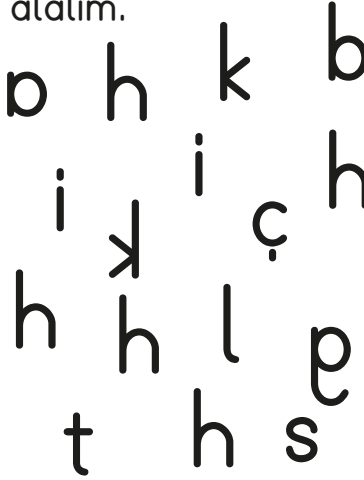

- Noktaları birleştirelim.

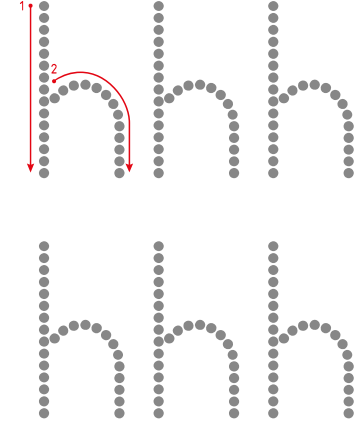

Yazma yönlerine dikkat ederek "h" harfini yazalım.

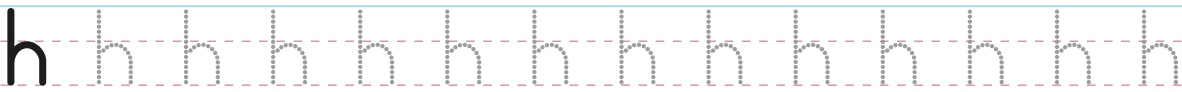
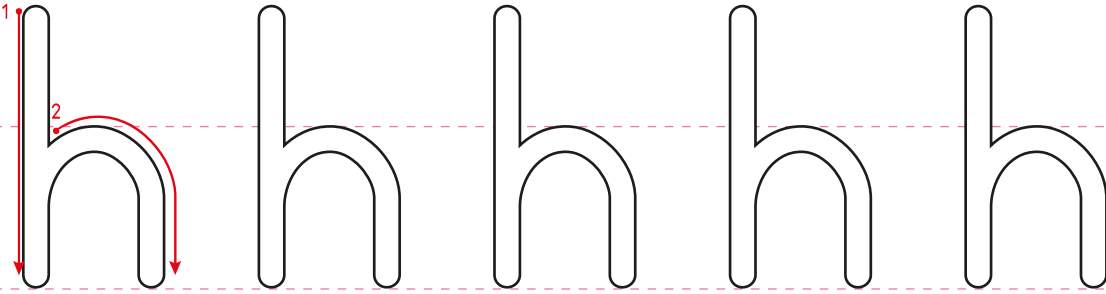



👉 "h" harfini yazalım.

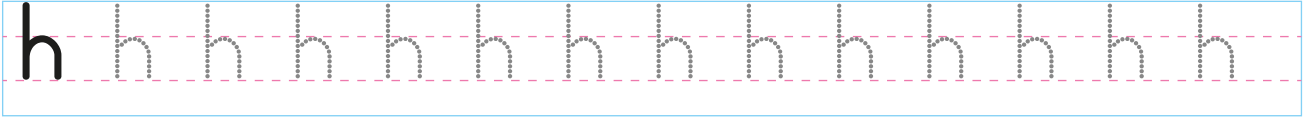
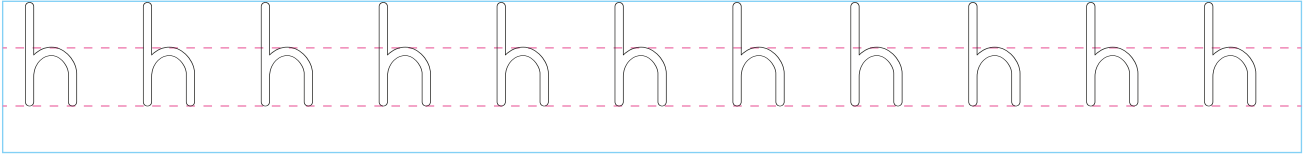



👉 Büyük "H" ve küçük "h" harfini yazalım.

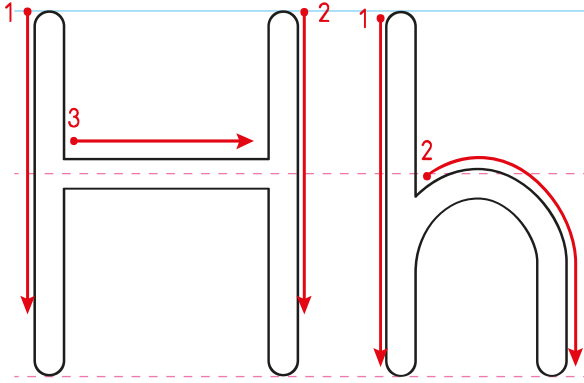

H H

h h h h

h h h h

h

h

h

h



Okuyalım, yazalım.

e h eh

h e he

a h ah

h a ha

i h ih

h i hi

o h oh

h o ho

he ce hece

He lin Helin

Helin hecele.

Ah met Ahmet

ha lı halı

Ahmet halı aldı.

da hi dahi

Hi lal Hilal

Hilal bir dahi.

ho roz horoz

ho bi hobi

Horoz öter.



Okuyalım, yazalım.

u h uh

h u hu

ü h üh

h ü hü

ö h öh

h ö hö

ı h ih

h ı hi

hu zur huzur

hu kuk hukuk

Huzurlu ol.

hü ner hüner

Hül ya Hüllya

Hüllya hünerli.

şö h şö

şöh ret şöret

Şöhreti bulmuş.

hı z hız

hız lı hızlı

Hızlı gidiyor.



☞ Kelimeleri okuyalım, yazalım.

hak

hiç

huy

hür

halk

harç

hırs

taht

hala

hata

ahır

halı

sabah

hasta

hamsi

nohut

siyah

timsah

hindi

hazır

ahtapot

hemşire

hazine

☞ Karışık hecelerden kelime oluşturalım.

pot	ah	ta	▶
he	ye	di	▶
ka	hi	ye	▶
ta	ri	ha	▶
hem	re	şi	▶

☞ Cümleleri görsellerin adlarıyla tamamlayalım. Cümleleri okuyalım.



Bu sabah ötmedi.

Annem yemeği yaptı.

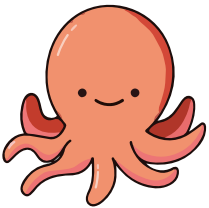

..... nerede yaşar?

Hilmi siyah almış.

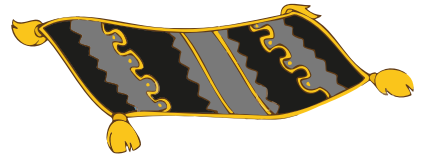

Ahu pazardan al.



☞ Cümleleri okuyalım. Okudukça kalpleri boyayalım.

♡ Halam, sabah erken uyanır.

♡ Hasan, mühendis olmak istiyor.

♡ Bahar, bahçeden ıhlamur topladı.

♡ Hande, hikâyeyi hece hece okudu.

♡ Hülya hızlı koştu, düştü.

♡ Halime, siyah hırka giymiş.

♡ Erhan, Hale'ye hediye almış.

♡ Muhtar, sabah bize geldi.

♡ Şahin, hep haber izliyor.

♡ Hatice, haşlanmış hindi yedi.



👉 Aynı rakamlarda yazılı kelimelerle cümleler oluşturup yazalım.

1 hamsi

2 tohum

3 Mehtap

4 Ahmet

3 okuyor

2 Hilmi

5 hemen

4 halı

1 Hasan

2 ekti

5 Cihan

4 bahçede

5 çık

5 bahçeye

4 çırpıyor

3 hukuk

1 tuttu

2 dayı

1

2

3

4

5

Metni okuyalım. Görseli boyayalım.

HAKAN'IN HATASI

Hakan, bahçeye çıkmıştı. Bahçede top oynadı. Terledi, susadı. Hemen gidip su içti. Hata yapmıştı. Hasta oldu. Annesi onu hastaneye götürdü. Hekim ona hap yazdı. Hakan hapını her gün içti. Annesi ihlamur yaptı. Onu da içti. Tahin pekmez yedi. Hemencecik iyileşti. Bir daha hata yapmadı.

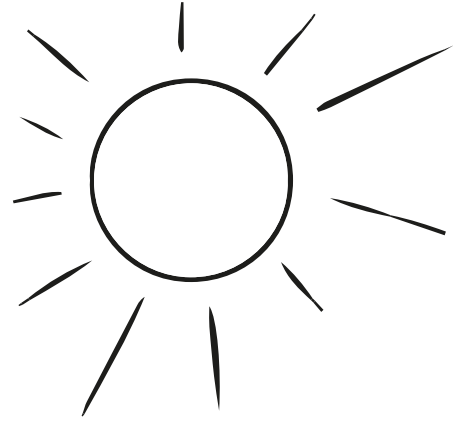



👉 Soruları cevaplayalım.

1. Hakan, nereye çıkmış?

2. Hakan'ın hatası neymiş?

3. Annesi Hakan'ı nereye götürmüştü?

4. Hekim, Hakan'a ne yazmış?

👉 Doğru mu, yanlış mı?

CÜMLELER	Doğru	Yanlış
Hakan, bahçeye çıkmış.		
Bahçede elma toplamış.		
Hakan hasta olmuş.		
Halası hastaneye götürmüştü.		
Hekim ona şurup yazmış.		
Annesi ihlamur yapmış.		



☞ Soruları cevaplayalım.

Hasan hızlı koşar.

- Kim hızlı koşar?

- Hasan nasıl koşar?

Hacer hekim oldu.

- Kim hekim oldu?

- Hacer ne oldu?

Sabah kar yağdı.

- Sabah ne yağdı?

- Kar ne zaman yağdı?

Mahir, hamakta sallanır.

- Kim hamakta sallanır?

- Mahir nerede sallanır?



☞ Soruları cevaplayalım.

Haritadan şehir
baktı.

- Nereden şehir baktı?

- Haritadan ne baktı?

Hemşire merhem
sürdü.

- Kim merhem sürdü?

- Hemşire ne sürdü?

Hande'den haber
geldi.

- Kimden haber geldi?

- Hande'den ne geldi?

Hasan hamsi yedi.

- Kim hamsi yedi?

- Hasan ne yedi?



Metni okuyalım, soruları cevaplayalım.

HÜLYA'NIN HEYECANI

Hülya, okuldan gelmişti. İçeri girince çok heyecanlandı. Çünkü halası oradaydı. Halasına koştu, boynuna sarıldı. Halası ona hediye almıştı. Hülya hemen hediyeyi açtı. Oyun hamuru çıktı. Hülya, hop hop zıpladı. Mutlu olmuştu. Bu harika bir hediyeydi. Ellerini yıkadı. Oynamaya başladı. Heykeller yaptı. Horoz heykeli ve hindi yaptı. Saatlerce hamurla oynadı.

1. Hülya neden heyecanlanmış?

2. Halası ona ne almış?

3. Hamurdan neler yapmış?

👉 Noktalı yerlere uygun meslek isimlerini yazalım.

hemşire

hekim

hakem

hostes

hakim

mühendis



Zuhal



Hakan

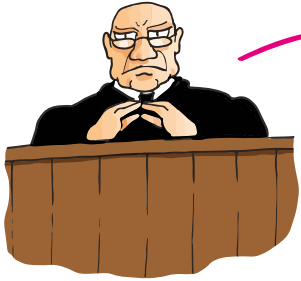

Hilmi



Bahar



Hande



Hikmet



☞ Soruları cevaplayalım. Yönergeleri uygulayalım.

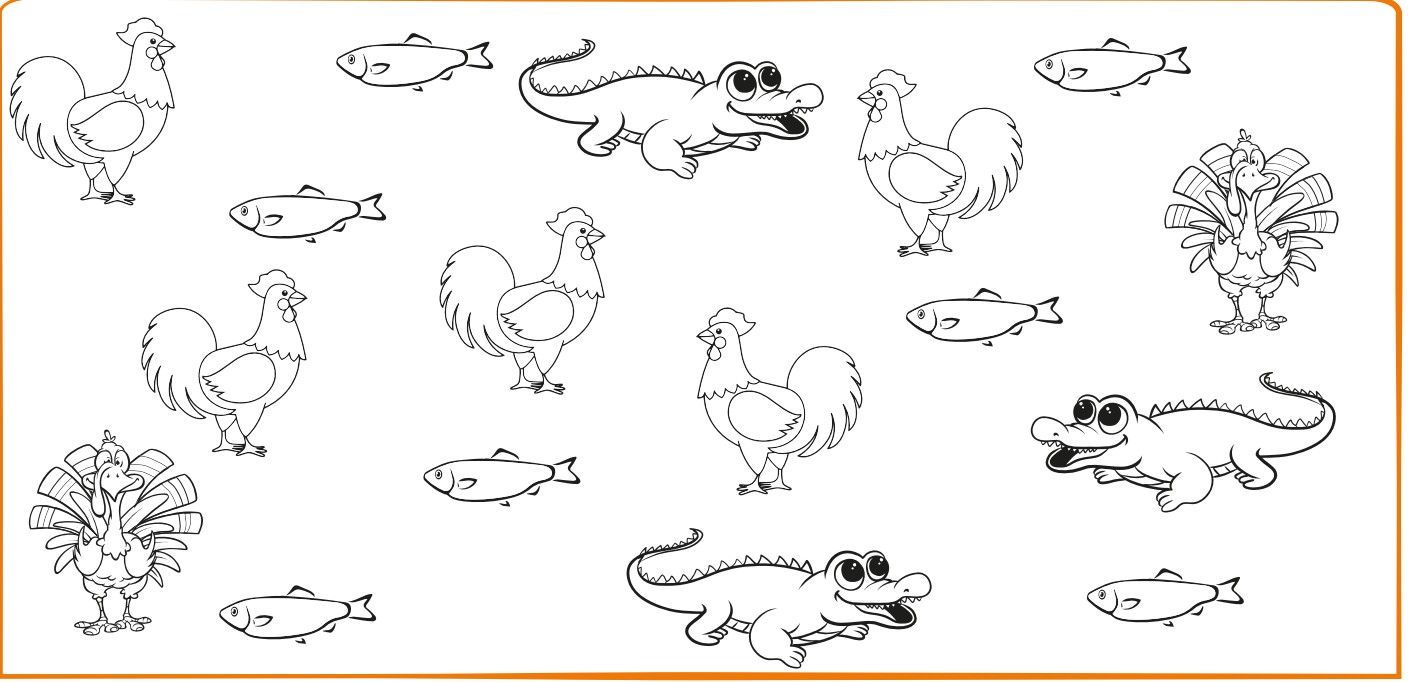

1. Horozlar kaç tane?

2. Hindiler kaç tane?

3. Timsahlar kaç tane?

4. Hamsiler kaç tane?

- Hamsileri siyaha boyayalım.
- Hindileri kırmızıya boyayalım.
- Timsahları yeşile boyayalım.
- Horozları kahverengiye boyayalım.

Adında "v" sesi bulunan varlıkları boyayalım.



"v" sesi ile başlayan varlıkları işaretleyelim.





👉 Büyük "V" harfinin yazılış yönüne dikkat edelim. İçinden kalemimizle geçelim.

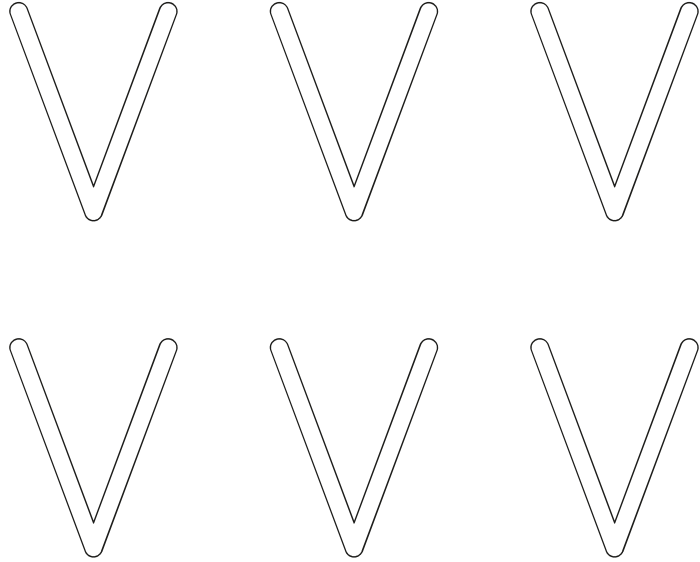
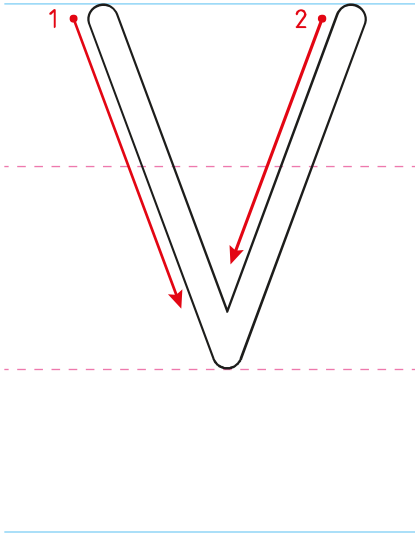

👉 "V" harfinin yazılı olduğu balonları boyayalım.

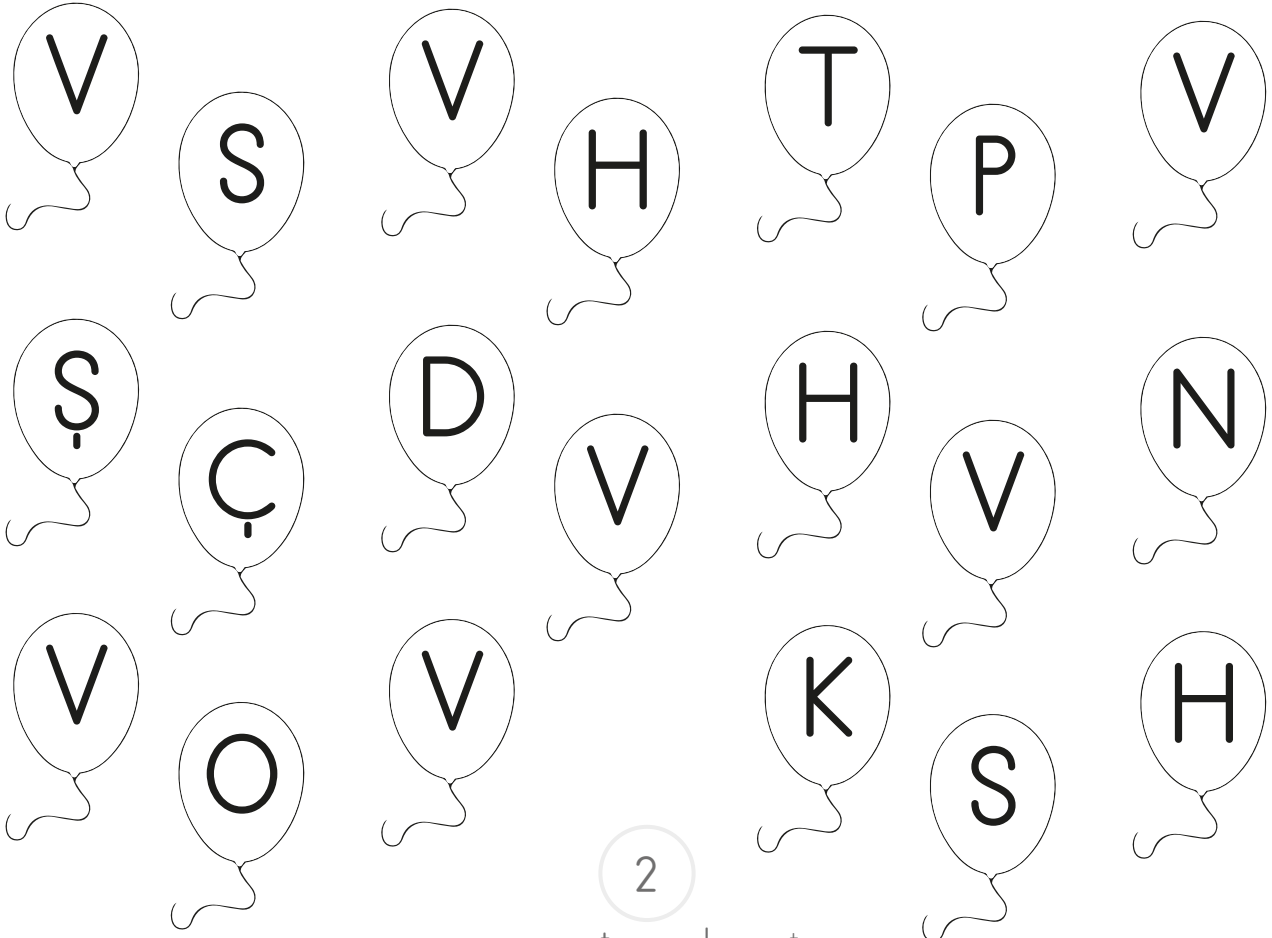

Yönergeleri uygulayalım.

• "V" harfini boyayalım.

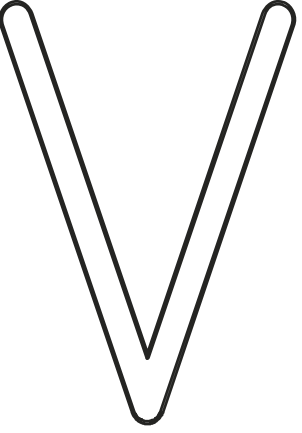

• "V" harflerini bulup yuvarlak içine alalım.

P p V H
V i S n
e O V
V p V ş

• Noktaları birleştirelim.

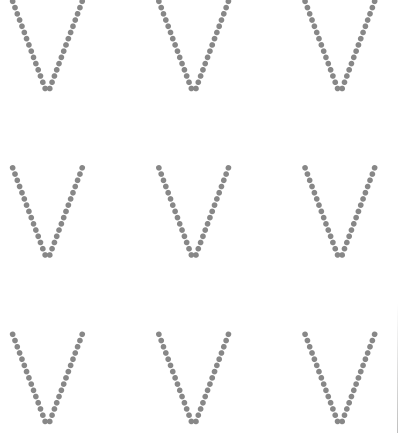

Yazma yönüne dikkat ederek "V" harfini yazalım.

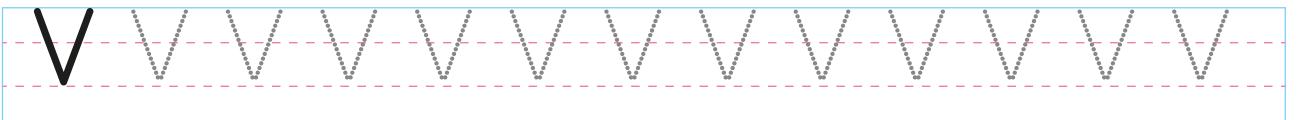
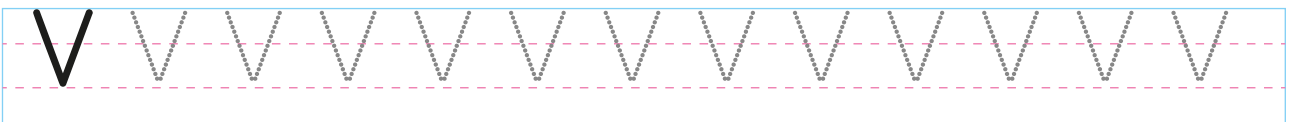
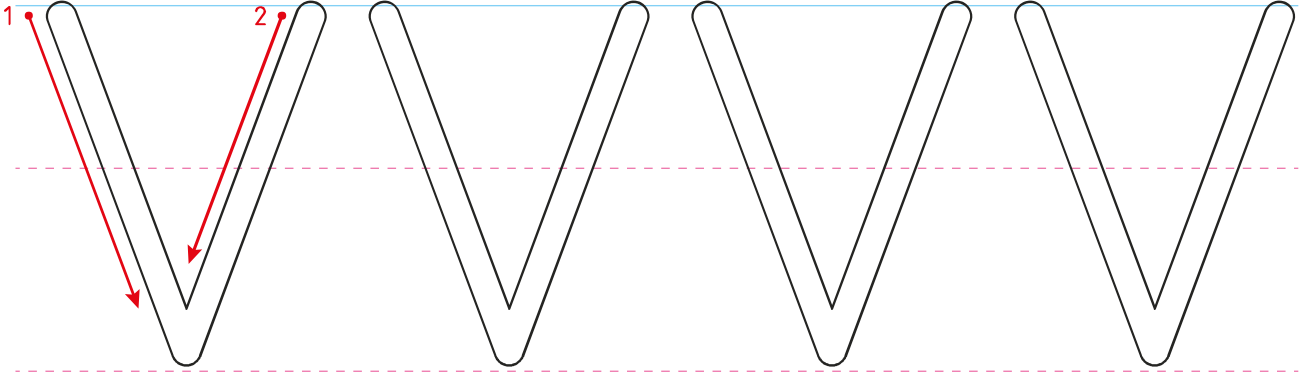



👉 "V" harfini yazalım.

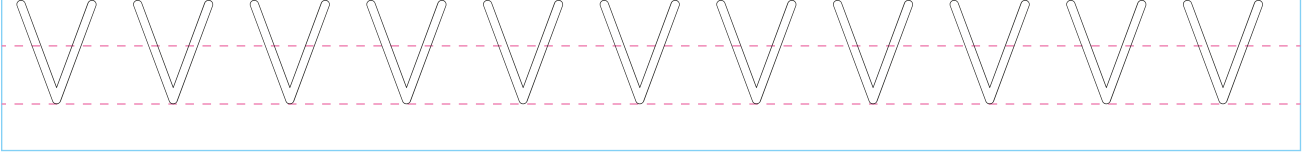



☞ Küçük "v" harfinin yazılış yönüne dikkat edelim. İçinden kalemimizle geçelim.

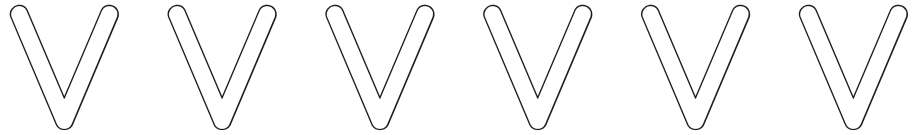
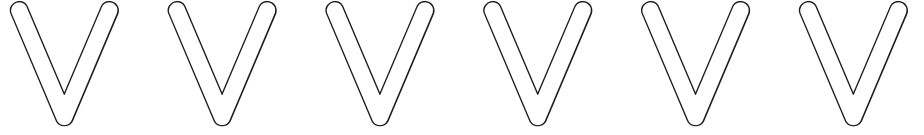
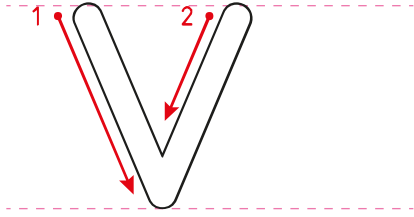

☞ "v" harfinin yazılı olduğu yıldızları boyayalım.

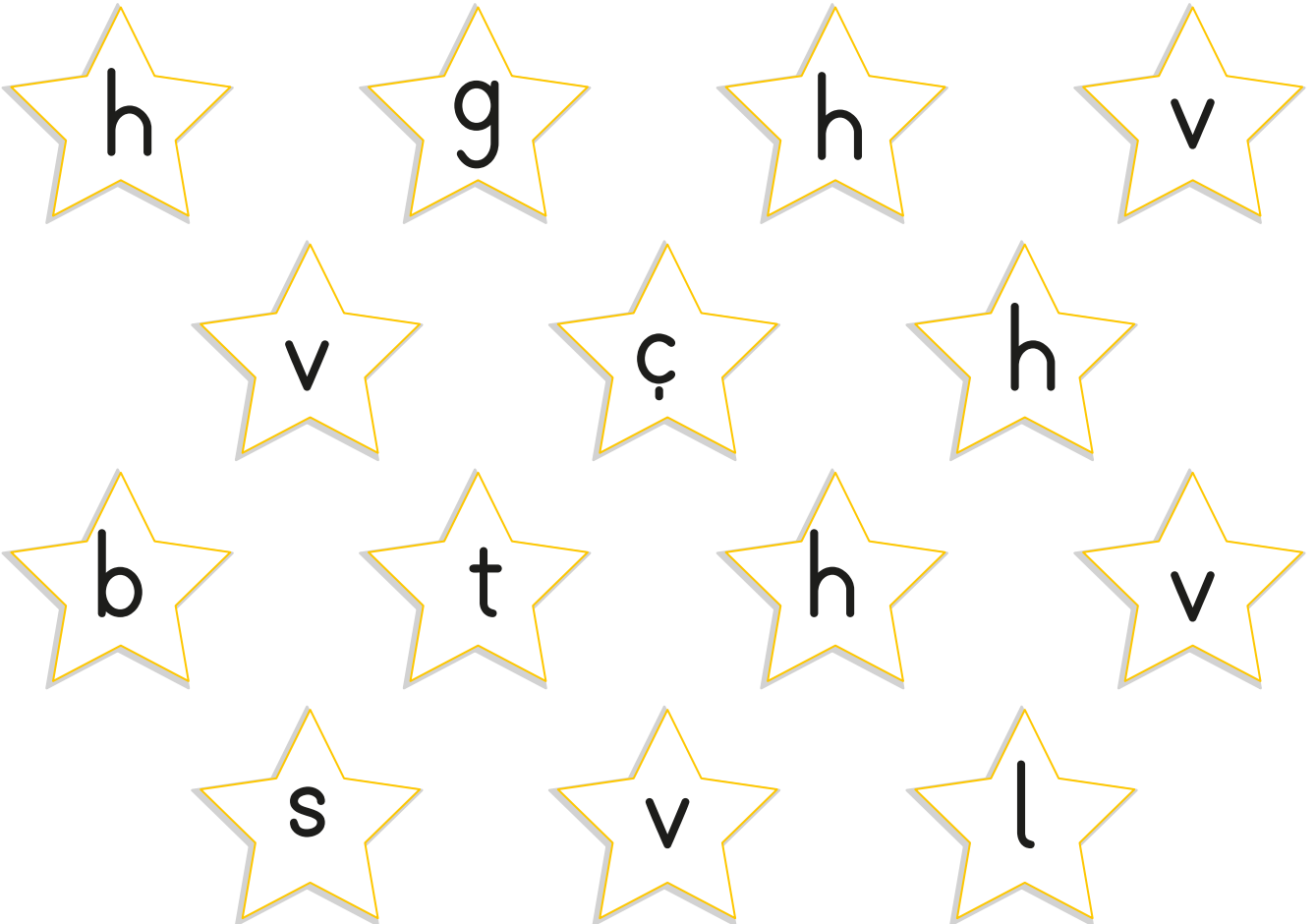

Yönergeleri uygulayalım.

• "v" harfini boyayalım.

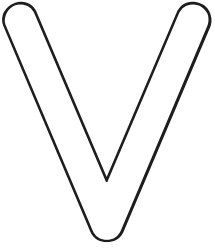

• "v" harflerini bulup yuvarlak içine alalım.

b h v b
v k i ç h
v v l n
t v s

• Noktaları birleştirelim.

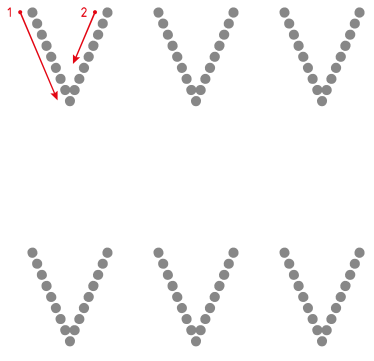

Yazma yönlerine dikkat ederek "v" harfini yazalım.

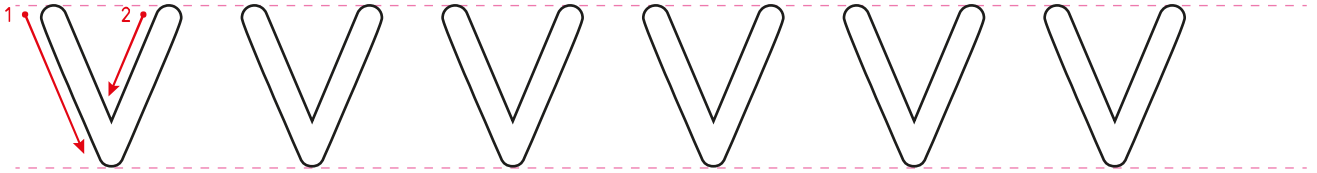

v v v v v v v v v v v v v v v

v v v v v v v v v v v

v v v v v



☞ "v" harfini yazalım.

V V V V V V V V V V V V

V V V V V V V V V V V V V V V

V V V

V

V

V

V

V

V

V

V

V



👉 Büyük "V" ve küçük "v" harfini yazalım.

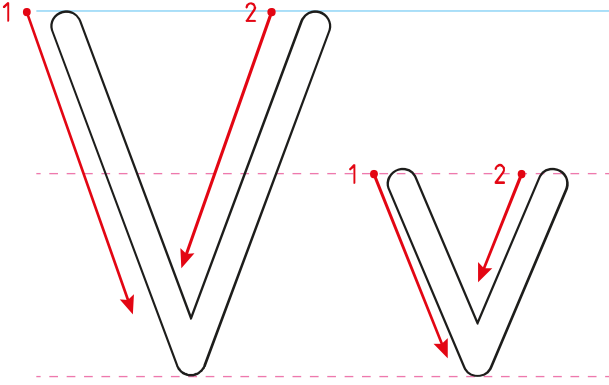



Okuyalım, yazalım.

e v ev

v e ve

a v av

v a va

i v iv

v i vi

o v ov

v o vo

ev li evli

Ve li Veli

Veli ile evli.

ha va hava

yu va yuva

Yuva hava almış.

vi da vida

Vil dan Vildan

Vildan vida al.

vo kal vokal

Vol kan Volkan

Volkan vokal yap.



Okuyalım, yazalım.

u v uv

v u vu

ü v üv

v ü vü

ö v öv

v ö vö

ı v ıv

v ı vı

ha vuz havuz

ta vuk tavuk

Tavuk yedim.

vü cut vücut

öv gü övgü

Vücutta yara olmuş.

Bu övgüyü hak ediyorsun.

Arı vız vız etti.

Bol sıvı tüket.



☞ Kelimeleri okuyalım, yazalım.

ver

var

vur

sev

veya

vazo

mavi

kivi

havuz

cevap

pilav

evlat

vagon

havuç

Mevlüt

Elvan

eldiven

merdiven

vitamin

kavanoz

veteriner

tornavida

☞ Karışık hecelerden kelime oluşturalım.

vo	bol	ley	▶		
tı	kah	val	▶		
va	bak	la	▶		
min	ta	vi	▶		
te	yon	le	viz	▶	

☞ Cümleleri görsellerin adlarıyla tamamlayalım. Cümleleri okuyalım.



Tavşan üç yedi.

..... ile tüm gün dolaştık.

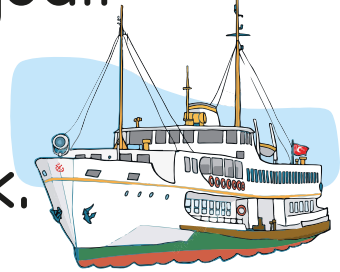

Vildan iki su taşıdı.

Kümeşte yedi var.

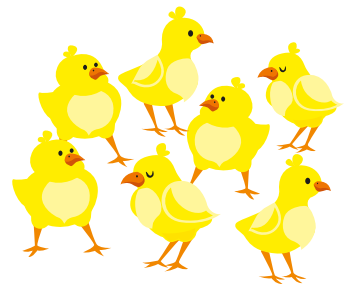

..... ile yılan arkadaş olmuş.



☞ Cümleleri görseli ile eşleştirelim.

Levent cetvel almış.

Vildan ödev yapıyor.

Tavşan havuç sever.

Volkan ceviz yer.

Veli ayva topluyor.

Vişne çok lezzetli.

Tabakta kavun var.

Evde davul çalma.

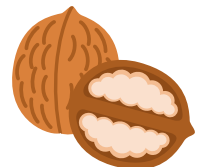
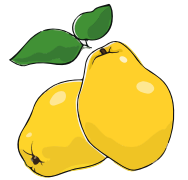
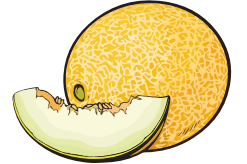



☞ Metni okuyalım. Aşağıya yazalım.

MEYVELER

Güzeldir meyvelerin hepsi

Vişne, kavun, ayva, kivi

Vitamin dolu hep içleri

Meyve yiyen çocukların

Kuvvetli olur kemikleri



Handwriting practice line with a dashed red line for the middle and solid blue lines for the top and bottom.

Handwriting practice line with a dashed red line for the middle and solid blue lines for the top and bottom.

Handwriting practice line with a dashed red line for the middle and solid blue lines for the top and bottom.

Handwriting practice line with a dashed red line for the middle and solid blue lines for the top and bottom.

Handwriting practice line with a dashed red line for the middle and solid blue lines for the top and bottom.

Handwriting practice line with a dashed red line for the middle and solid blue lines for the top and bottom.



👉 Metni okuyalım, soruları cevaplayalım.

VEDA

Vildan eve gelmiş. Kapının önünde valiz varmış. Mavi valizi hep babası kullanırmış. Yavaşça salona geçmiş. Babası Vildan'ı görünce kalkmış. "Van'a gitmem gerek. Ama hemen dönerim." demiş. Vildan'ın babası valiymiş. Vildan babasına veda etmiş. Üzülmüş. Ama bu onun işi için gerekiymiş. Vildan odasına gitmiş. Ödevini yapmış.

1. Valiz ne renkmiş?

2. Babası nereye gidecekmış?

3. Vildan odasında ne yapmış?



☞ Görsele uygun bir cümle yazalım.



Blank writing area with a dashed line for tracing.

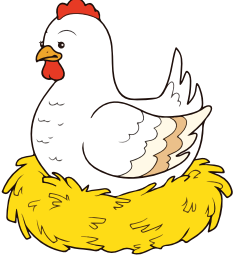

Blank writing area with a dashed line for tracing.



Blank writing area with a dashed line for tracing.



Blank writing area with a dashed line for tracing.



Blank writing area with a dashed line for tracing.



Blank writing area with a dashed line for tracing.

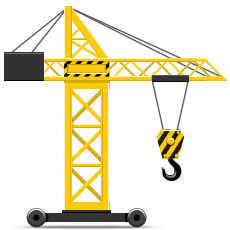

Blank writing area with a dashed line for tracing.

👉 Adında "ğ" sesi bulunan varlıkları boyayalım.

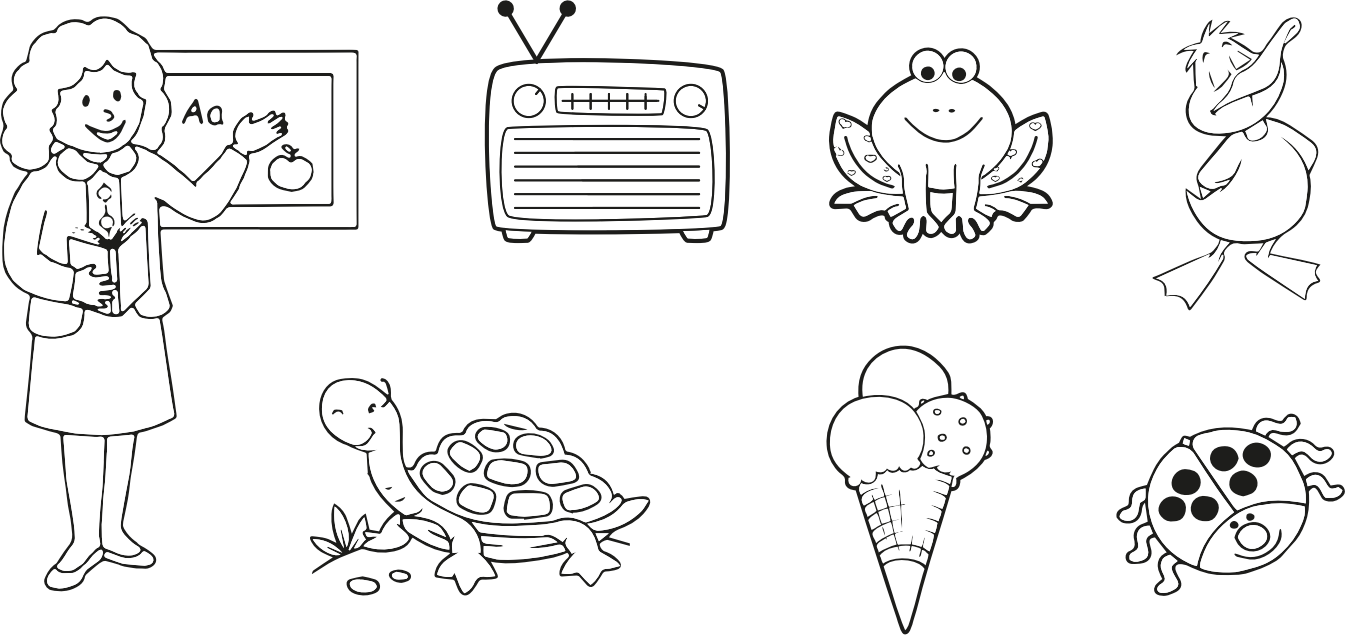

👉 İçinde "ğ" sesi olanları işaretleyelim.



☞ Büyük "Ğ" harfinin yazılış yönüne dikkat edelim. İçinden kalemimizle geçelim.

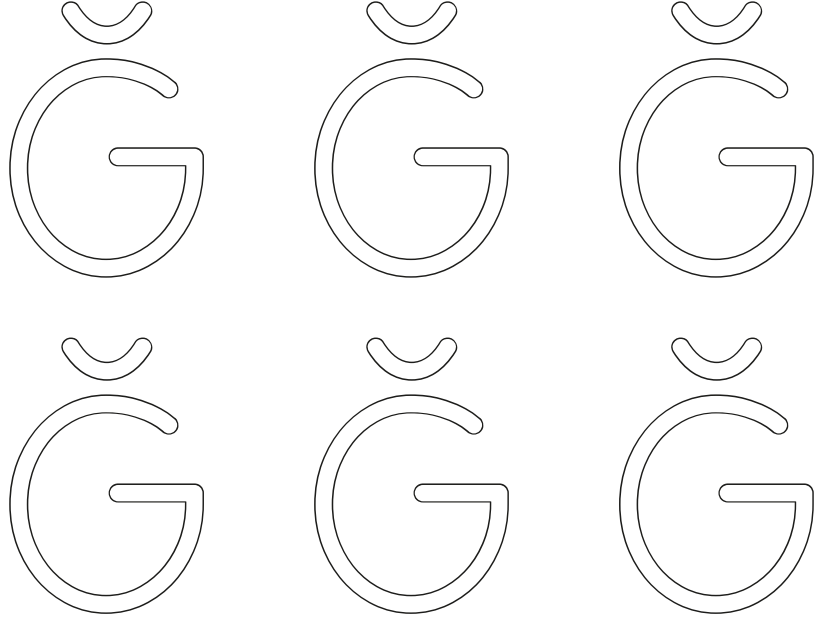
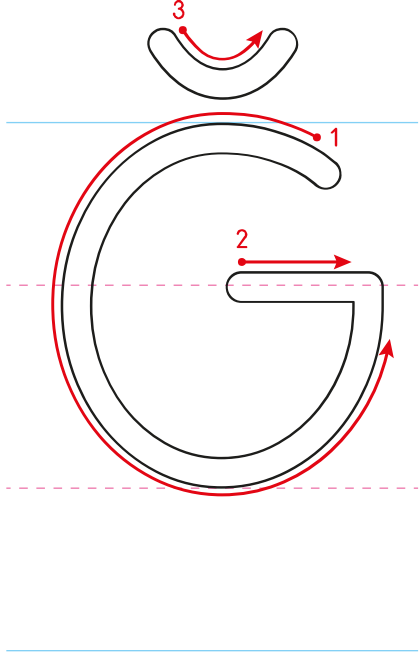

☞ "Ğ" harfinin yazılı olduğu balonları boyayalım.

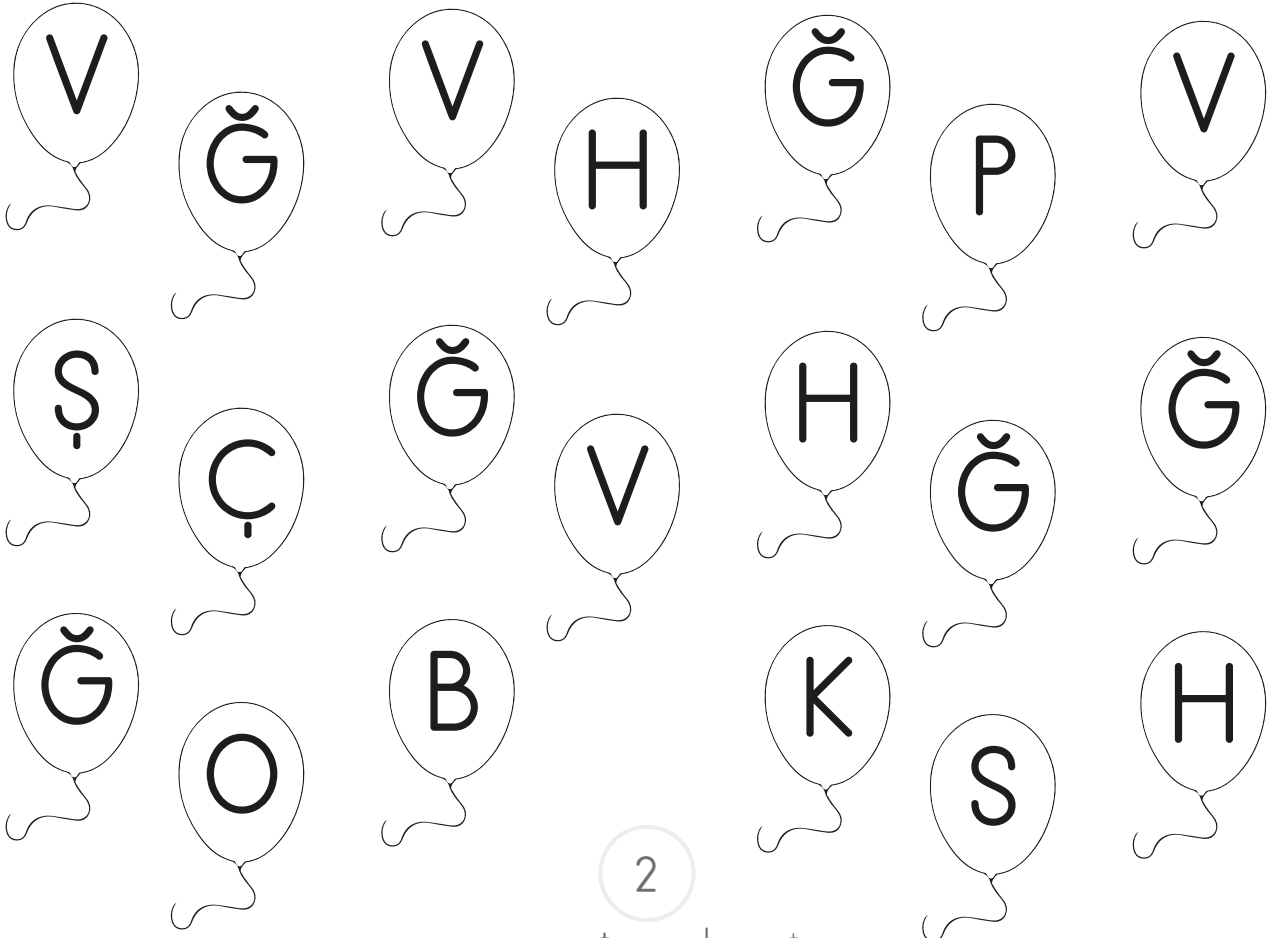

Yönergeleri uygulayalım.

• "Ğ" harfini boyayalım.

• "Ğ" harflerini bulup yuvarlak içine alalım.

• Noktaları birleştirelim.

Yazma yönüne dikkat ederek "Ğ" harfini yazalım.



☞ "Ğ" harfini yazalım.

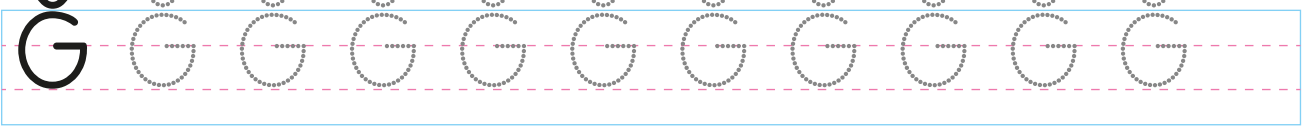
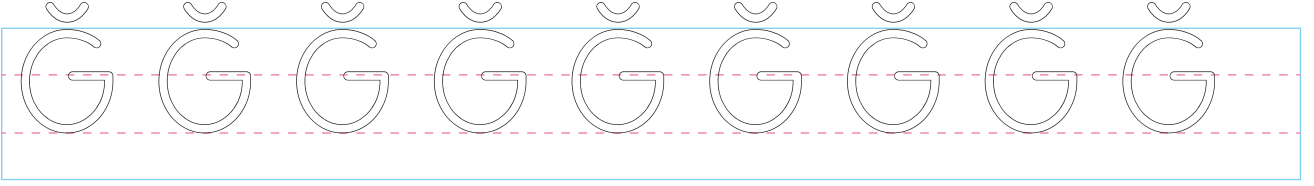

☞ Küçük "ğ" harfinin yazılış yönüne dikkat edelim. İçinden kalemimizle geçelim.

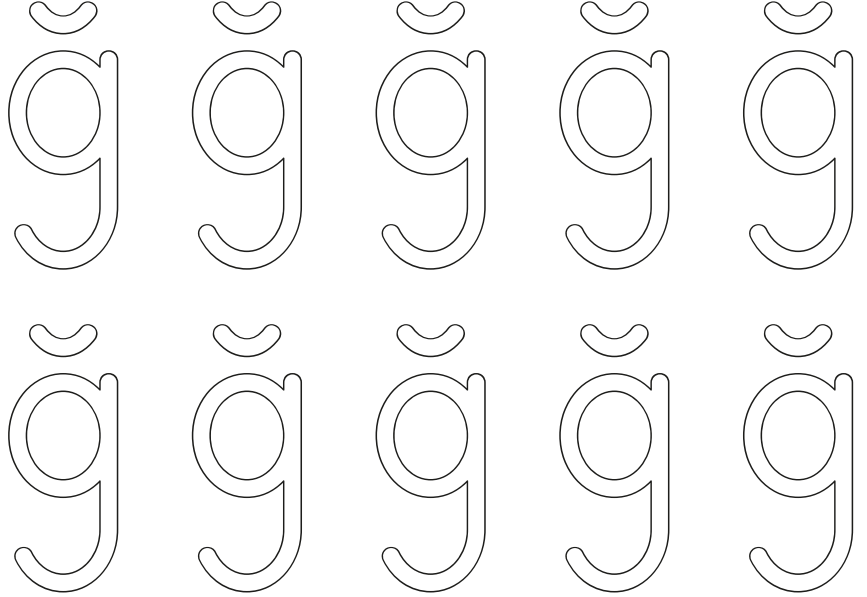
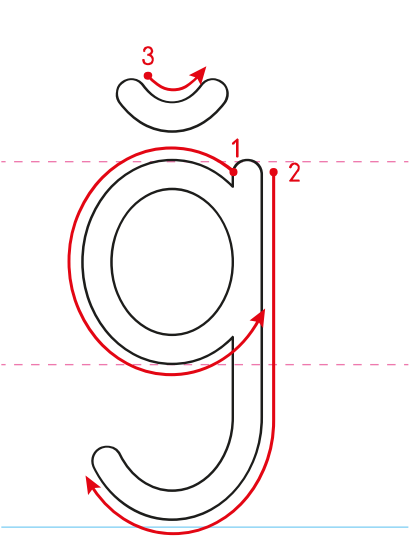

☞ "ğ" harfinin yazılı olduğu yıldızları boyayalım.

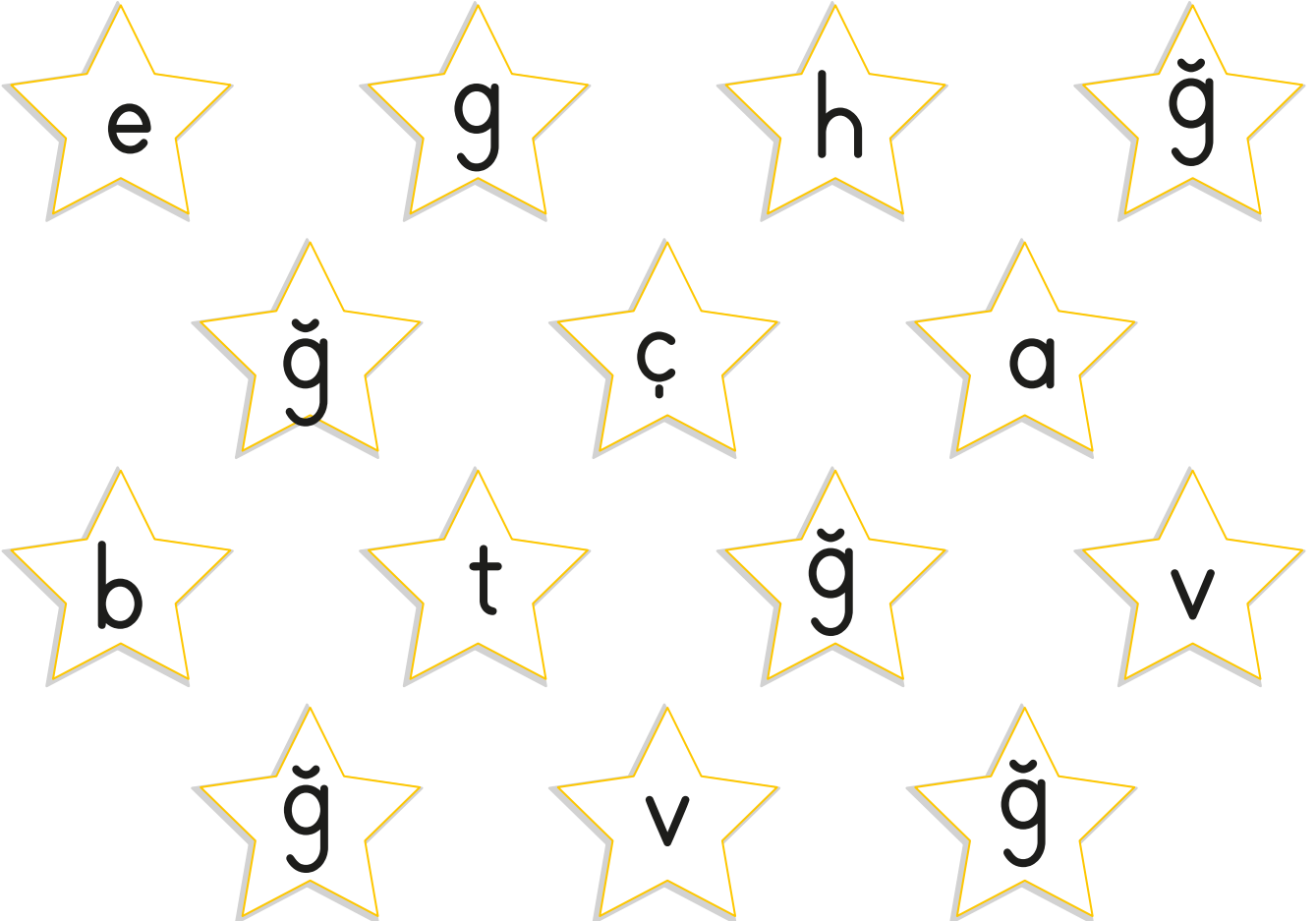

Yönergeleri uygulayalım.

• "ğ" harfini boyayalım.



• "ğ" harflerini bulup yuvarlak içine alalım.

b h v ğ
ğ k i ç h
v v ğ n
ğ v s

• Noktaları birleştirelim.

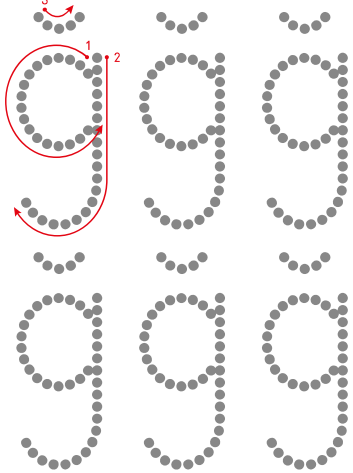

Yazma yönlerine dikkat ederek "ğ" harfini yazalım.

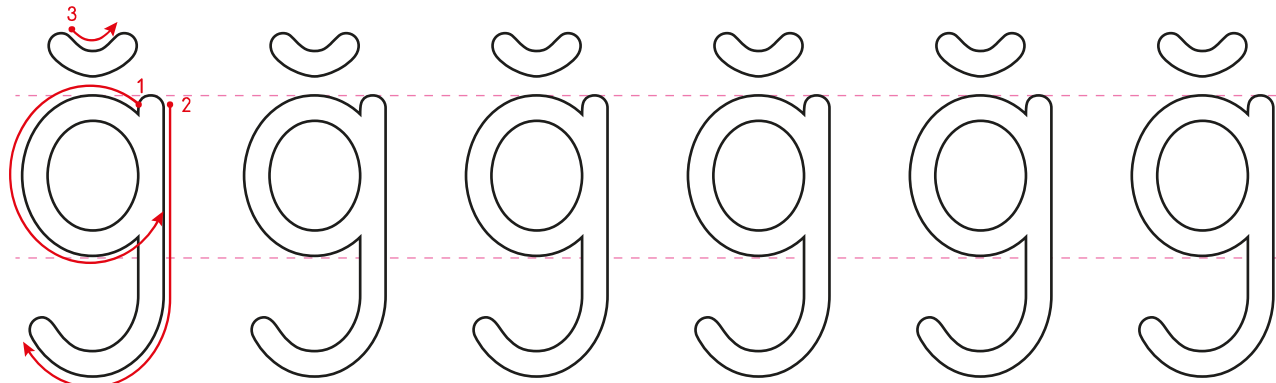

ğ ğ ğ ğ ğ ğ ğ ğ ğ ğ ğ ğ ğ ğ

ğ ğ ğ ğ ğ ğ ğ

ğ ğ ğ



☞ "ğ" harfini yazalım.

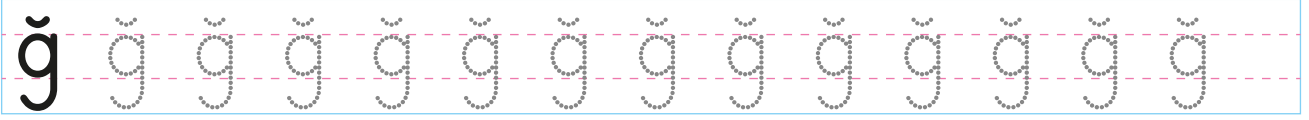
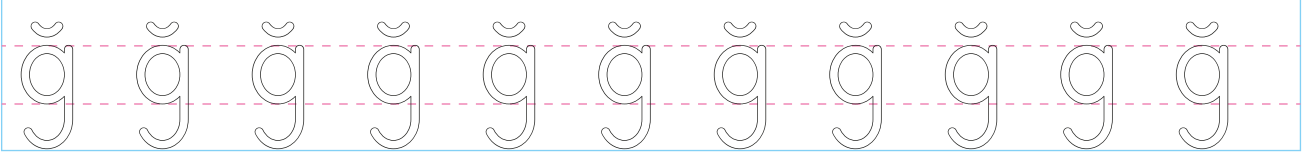



👉 Büyük "Ğ" ve küçük "ğ" harfini yazalım.

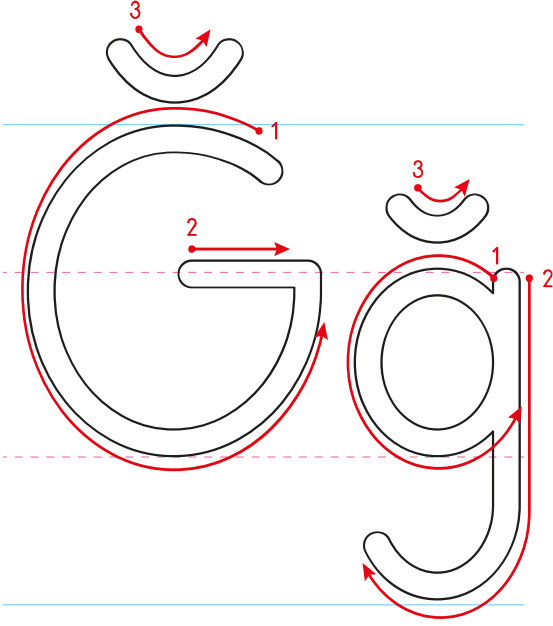

Ğ Ğ Ğ Ğ Ğ Ğ

Ğ Ğ Ğ

Ğ

Ğ

Ğ Ğ

ğ ğ ğ ğ

ğ ğ ğ ğ

ğ

ğ

ğ

ğ



Okuyalım, yazalım.

e	ğ	eğ	ğ	e	ğe
a	ğ	ağ	ğ	a	ğa
i	ğ	iğ	ğ	i	ği
o	ğ	oğ	ğ	o	go
u	ğ	uğ	ğ	u	gu
ü	ğ	üğ	ğ	ü	gü
ö	ğ	öğ	ğ	ö	gö
ı	ğ	iğ	ğ	ı	ğı

eğri eğri ağrı ağrı doğa doğa

iğne iğne iğde iğde oğlak oğlak

uğrak uğrak doğu doğu öğlen öğlen



☞ Kelimeleri okuyalım, yazalım.

yağ

sağ

dağ

çiğ

ağrı

ağaç

boğa

öğüt

Çağla

Çağrı

Buğra

Kağan

Doğan

Tuğrul

Uğur

Yiğit

soğuk

düğün

yoğurt

soğan

kurbağa

armağan

değirmen



☞ Görseli verilen varlıkların adındaki eksik heceleri yazalım.



papa . . .



kurba . .



u . . . böce . .



. . . murluk



arma . . .



. . retmen

öğretmen

yoğurt

öğüt

iğde

soğan

- Uğur ağaçtan topladı.
- Öğle yemeğinde yedim.
- Çiğ yemeği sevmiyor.
- Çağla olmak istiyor.
- Ninem bize verdi.



☞ Cümleleri okuyalım. Okudukça balıkları boyayalım.

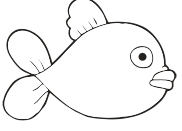

Ağrı Dağına gitmek ister misin?

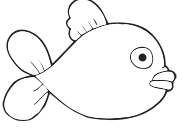

Leğende birçok çamaşır var.

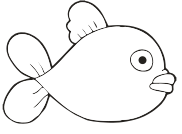

Ağaçtan iğde ile çağla topladık.

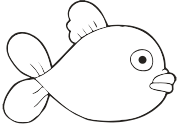

Muğla'da yağmur yağıyor.

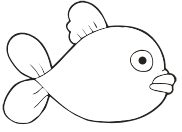

Uğur Doğan'ın düğmesi kopmuş.

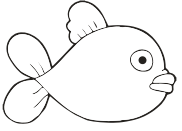

Oğuz dayım bağlama çalar.

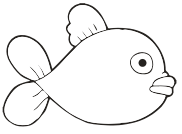

Eğitim her zaman çok önemlidir.

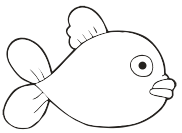

Çiğdem iğne olmalısın.

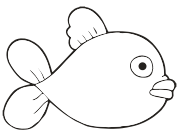

Tuğçe köyde kurbağa gördü.

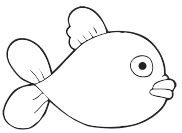

Yiğit yemeğe soğan doğradı.



👉 Aynı şeklin içindeki kelimelerle cümle oluşturalım. Cümleleri yazalım.

boğazımı

öğrenciyi

bağdan

tırmandı

Çiğdem

öğretmen

öğlen

soğuk

Yiğit

ağrıttı

çağırıldı

yağdı

yanına

üzüm

su

topladı

ağaca

yağmur

Blank writing line with a dashed red line for the middle and a solid blue line for the bottom.

Blank writing line with a dashed red line for the middle and a solid blue line for the bottom.

Blank writing line with a dashed red line for the middle and a solid blue line for the bottom.

Blank writing line with a dashed red line for the middle and a solid blue line for the bottom.

Blank writing line with a dashed red line for the middle and a solid blue line for the bottom.



👉 Soruları kısaca cevaplayalım.

Çiğdem düğmeyi
iğne ile dikti.

• Kim dikti?

• Neyi dikti?

• Ne ile dikti?

Buğra, Ağrı'da
dağa tırmandı.

• Kim tırmandı?

• Nerede tırmandı?

• Neye tırmandı?

Uğur öğlen poğaçaya
yedi.

• Kim yedi?

• Ne zaman yedi?

• Ne yedi?

Yağmur yağınca
ayağı ıslanmış.

• Niçin ıslanmış?

• Neresi ıslanmış?



👉 Metni okuyalım.

SOĞAN

Soğan sağlıklı bir sebzedir. Buğra ile toprağa soğan ektik. Soğanları sulamak istedik. O sırada yağmur yağdı. Yağmur soğanları suladı.

👉 Soruları cevaplayalım.

1. Soğan nasıl bir sebzedir?

2. Soğanları nereye ekmişler?

3. Soğanları ne sulamış?

👉 Metne uygun bir resim çizelim.

☞ Metni önce bir kez okuyalım. Sonra süre tutarak okuyalım. Bir dakikada kaç kelime okuduğumuzu tabloya yazalım.

SAĞLIK İÇİN

Sağlıklı olalım. Sağlık her şeyden önemlidir. Sabah, öğlen ve akşam sağlıklı besinler yiyelim. Yoğurt, süt tüketelim. Yağlı yiyecekleri çok yemeyelim. Bol bol doğada olalım. Spor yapalım. Soğuk su içmeyelim. Yağmurda çok kalmayalım. Akciğerleri koruyalım. Mevsimine uygun giysiler giyelim. Sağlıklı olursak mutlu oluruz. Her işimizi kolayca yaparız.

	Süre	Kelime Sayısı
1. Okuma	1 dakika kelime
2. Okuma	1 dakika kelime
3. Okuma	1 dakika kelime



👉 Kelimeleri doğru alanlara yapıştıralım.

deve	havuç	vişne	havlu
ayva	kurbağa	vazo	lahana
leğen	kivi	kova	hindi
karnabahar	iğde	horoz	soğan

SEBZE

MEYVE

HAYVAN

EŞYA



MATEMATİK

1

2

3

4

5

6

7

8

+

-

9

0

÷

×

=

?





👉 Toplama işlemlerini yapalım. Toplananların yerlerini değiştirerek işlemleri yeniden yapalım.

$$9 + 2 = \dots 11 \dots$$

$$\dots 2 \dots + \dots 9 \dots = \dots 11 \dots$$

$$6 + 4 = \dots \dots \dots$$

$$\dots \dots + \dots \dots = \dots \dots \dots$$

$$8 + 7 = \dots \dots \dots$$

$$\dots \dots + \dots \dots = \dots \dots \dots$$

$$5 + 11 = \dots \dots \dots$$

$$\dots \dots + \dots \dots = \dots \dots \dots$$

$$3 + 12 = \dots \dots \dots$$

$$\dots \dots + \dots \dots = \dots \dots \dots$$

$$6 + 9 = \dots \dots \dots$$

$$\dots \dots + \dots \dots = \dots \dots \dots$$

$$13 + 4 = \dots \dots \dots$$

$$\dots \dots + \dots \dots = \dots \dots \dots$$

$$16 + 3 = \dots \dots \dots$$

$$\dots \dots + \dots \dots = \dots \dots \dots$$

$$10 + 1 = \dots \dots \dots$$

$$\dots \dots + \dots \dots = \dots \dots \dots$$

$$11 + 7 = \dots \dots \dots$$

$$\dots \dots + \dots \dots = \dots \dots \dots$$

$$8 + 6 = \dots \dots \dots$$

$$\dots \dots + \dots \dots = \dots \dots \dots$$

$$14 + 5 = \dots \dots \dots$$

$$\dots \dots + \dots \dots = \dots \dots \dots$$

👉 Toplama işlemlerini yapalım. Toplananların yerlerini değiştirerek işlemleri yeniden yapalım.

$\begin{array}{r} 5 \\ + 9 \\ \hline \end{array}$ <p>.....</p> <p>.....</p>	$\begin{array}{r} 7 \\ + 7 \\ \hline \end{array}$ <p>.....</p> <p>.....</p>
$\begin{array}{r} 6 \\ + 4 \\ \hline \end{array}$ <p>.....</p> <p>.....</p>	$\begin{array}{r} 5 \\ + 0 \\ \hline \end{array}$ <p>.....</p> <p>.....</p>
$\begin{array}{r} 10 \\ + 5 \\ \hline \end{array}$ <p>.....</p> <p>.....</p>	$\begin{array}{r} 13 \\ + 6 \\ \hline \end{array}$ <p>.....</p> <p>.....</p>
$\begin{array}{r} 2 \\ + 7 \\ \hline \end{array}$ <p>.....</p> <p>.....</p>	$\begin{array}{r} 18 \\ + 2 \\ \hline \end{array}$ <p>.....</p> <p>.....</p>

İşlemlerin eşit olması için noktalı yerlere uygun sayılar yazalım.

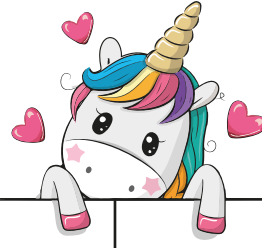

$8 + 3 = \dots + 8$	$9 + 2 = 2 + \dots$	$5 + \dots = 9 + 5$
$6 + \dots = 5 + 6$	$\dots + 11 = 11 + 6$	$7 + 5 = 5 + \dots$
$\dots + 7 = 9 + 7$	$15 + \dots = 15 + 4$	$3 + 10 = \dots + 3$
$3 + 15 = 3 + \dots$	$\dots + 1 = 0 + 1$	$4 + \dots = 7 + 4$
$\dots + 12 = 12 + 1$	$3 + \dots = 5 + 3$	$6 + 9 = \dots + 9$
$11 + \dots = 11 + 2$	$\dots + 6 = 3 + 6$	$8 + 7 = 7 + \dots$

☞ Görselleri inceleyelim, Örnekteki gibi açıklayalım.



Dalda 5 kuş varmış. 2 tanesi uçmuş. Daldaki kuş sayısı azalmış.

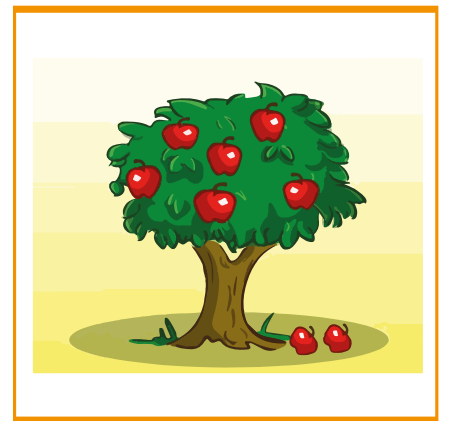
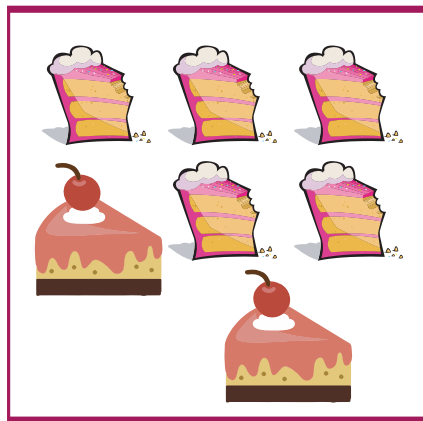
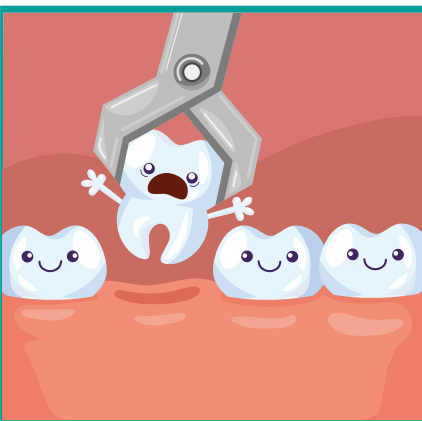
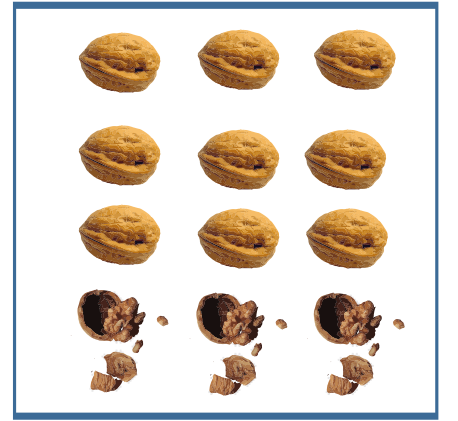
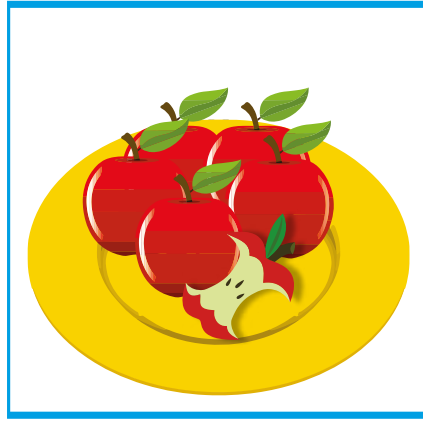

Modellenen çıkarma işlemlerini yapalım.

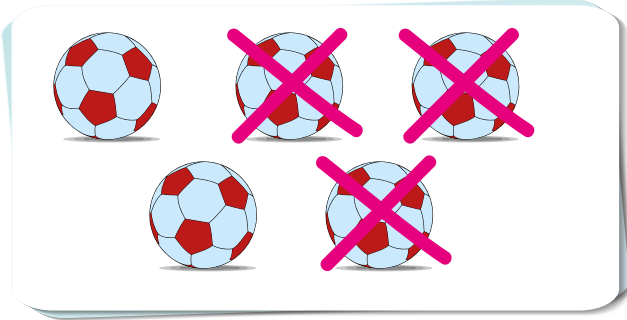

5 - 3 = 2



- =

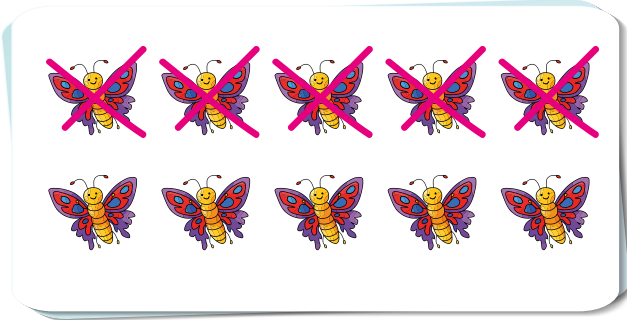

- =

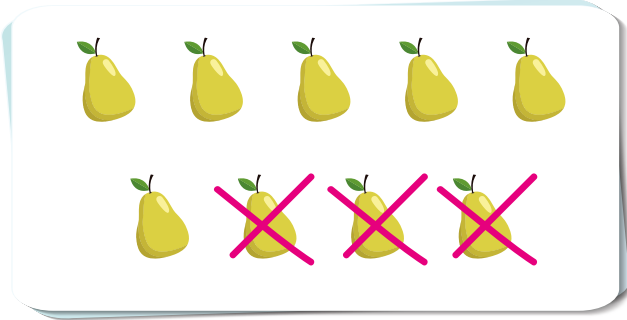



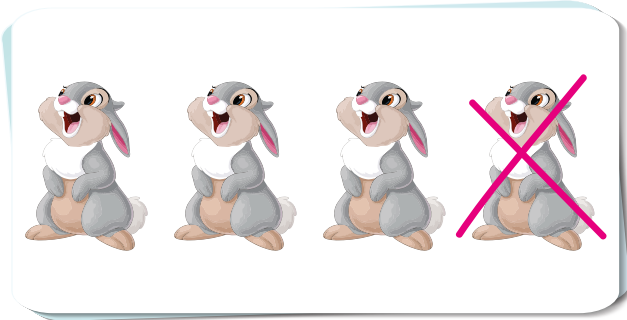





- =



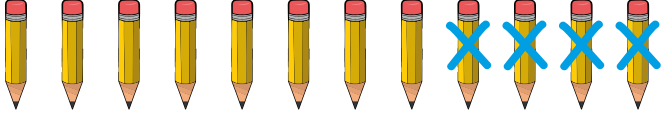

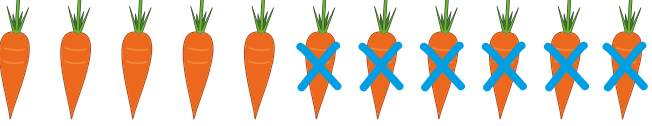

- =

Modellenen çıkarma işlemlerini yapalım.

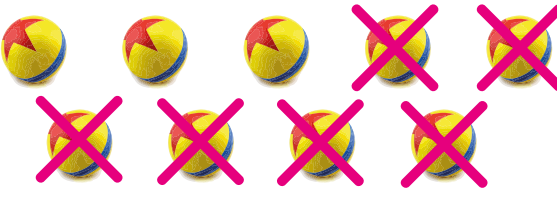
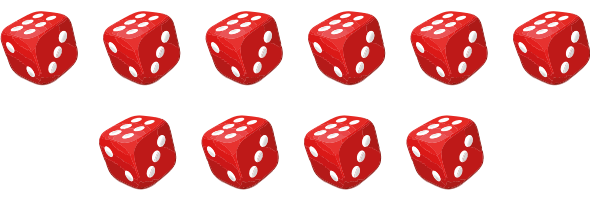
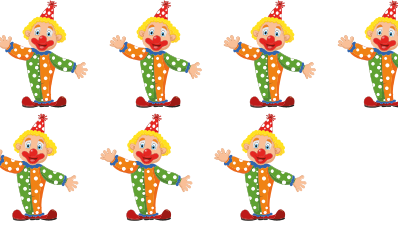
 <p>..... - =</p>	 <p>..... - =</p>
 <p>..... - =</p>	 <p>..... - =</p>
 <p>..... - =</p>	 <p>..... - =</p>
 <p>..... - =</p>	 <p>..... - =</p>
 <p>..... - =</p>	 <p>..... - =</p>

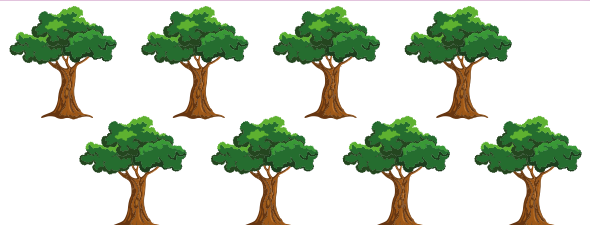
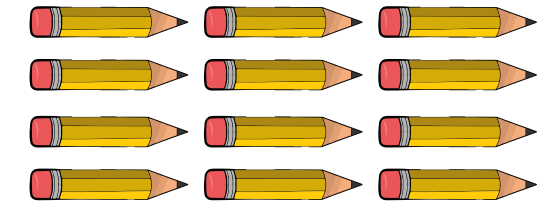
Verilen işlemleri örnekteki gibi yapalım.

$$9 - 6 = 3$$

$$10 - 3 = \dots$$

$$7 - 5 = \dots$$

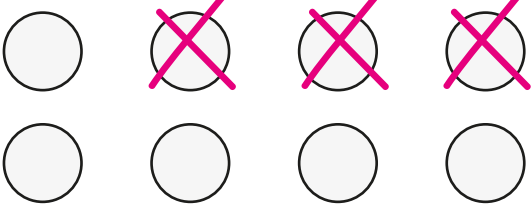
$$5 - 2 = \dots$$

$$3 - 1 = \dots$$

$$8 - 4 = \dots$$

$$12 - 3 = \dots$$

$$6 - 3 = \dots$$

Çıkarma işlemlerini örnekteki gibi şekil çizerek yapalım.

$$8 - 3 = \dots 5$$



$$10 - 4 = \dots$$

$$13 - 7 = \dots$$

$$9 - 5 = \dots$$

$$7 - 4 = \dots$$

$$12 - 7 = \dots$$

$$15 - 8 = \dots$$

$$8 - 2 = \dots$$