

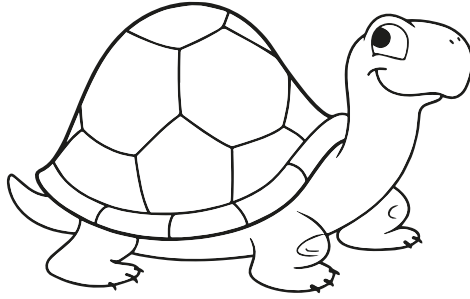

# Ş, C VE P SESİ ÇALIŞMALARI

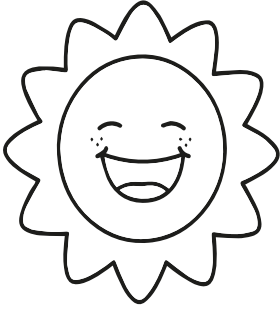

👉 Adında "ş" sesi bulunan varlıkları boyayalım.

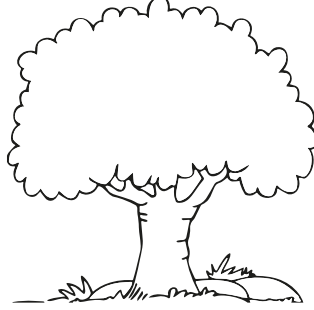
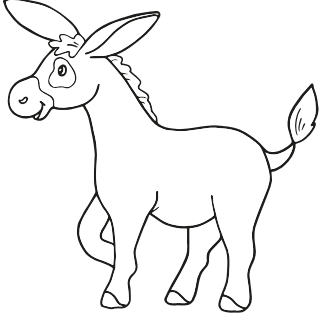

👉 "ş" sesi ile başlayan varlıkları işaretleyelim.

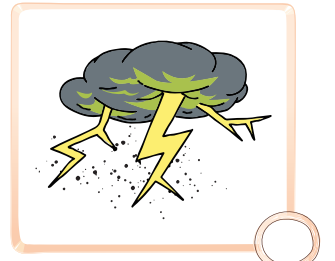
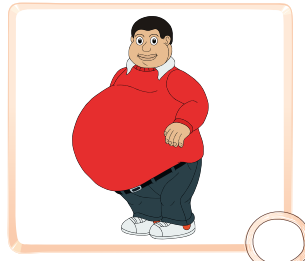
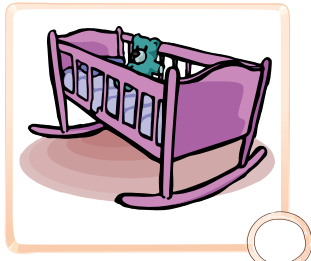
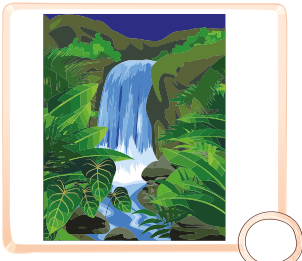
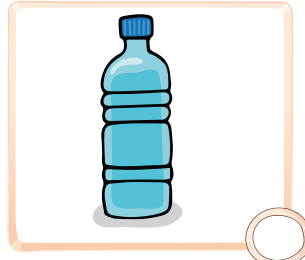
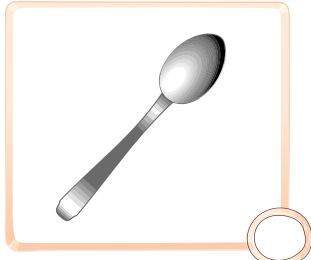
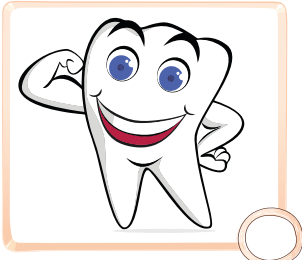
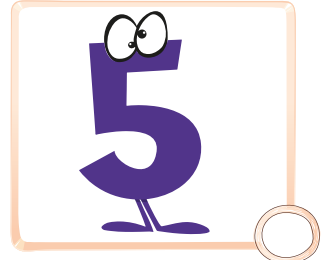

👉 Büyük "Ş" harfinin yazılış yönüne dikkat edelim. İçinden kalemimizle geçelim.

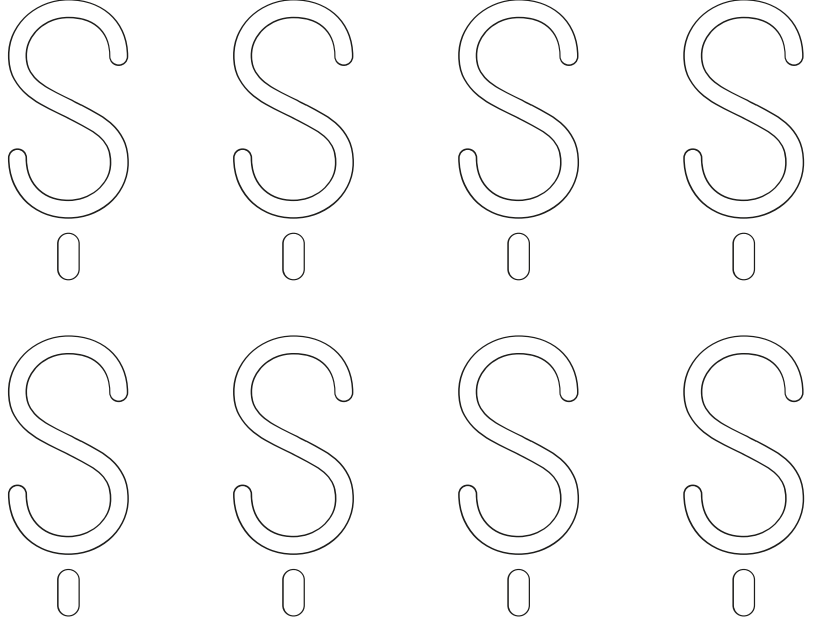
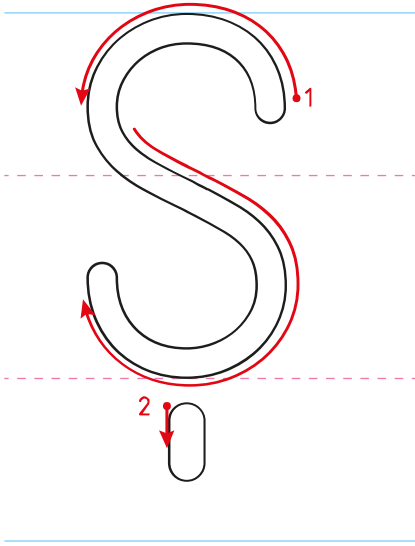

👉 "Ş" harfinin yazılı olduğu balonları boyayalım.

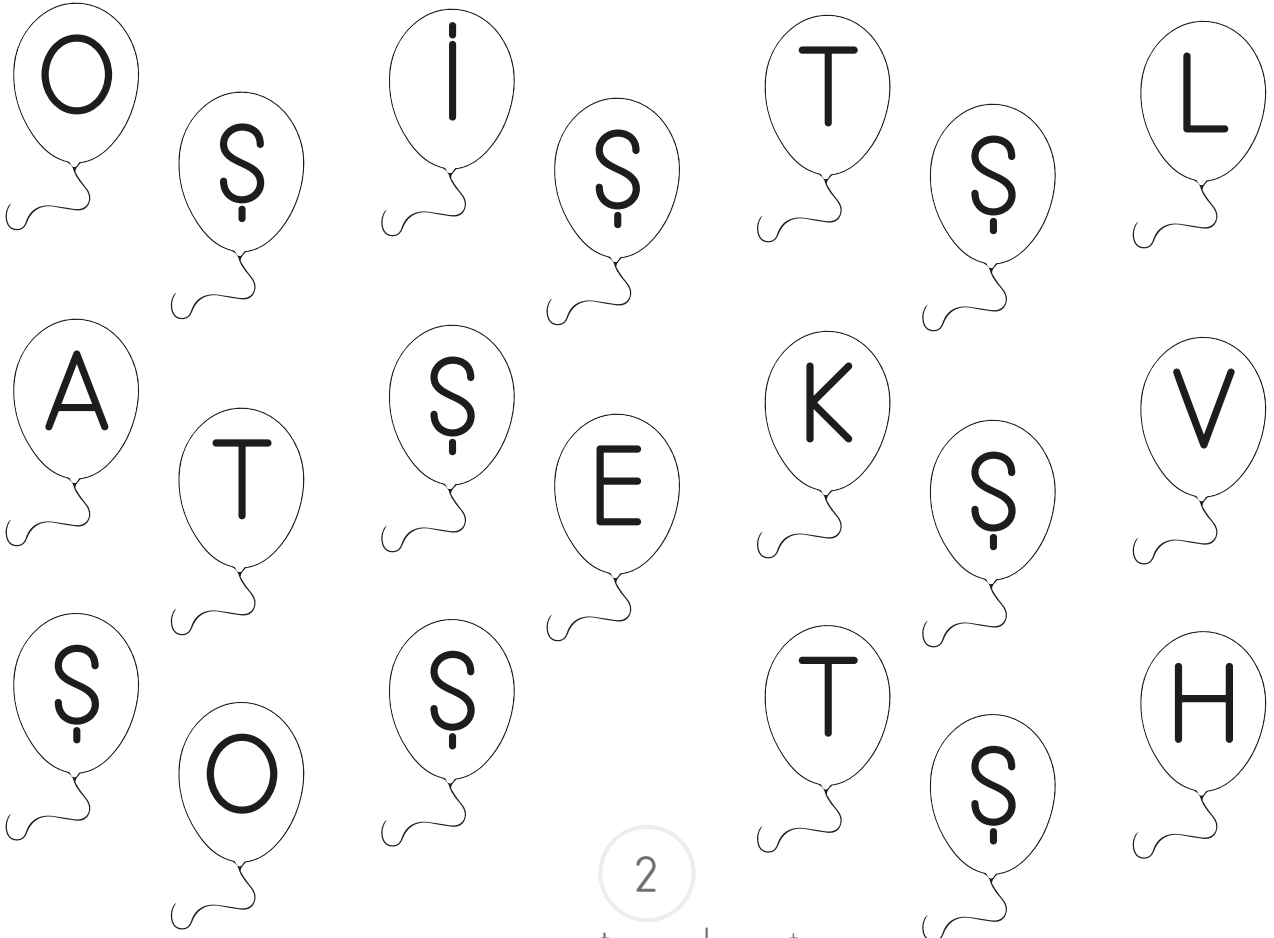

Yönergeleri uygulayalım.

• "Ş" harfini boyayalım.

• "Ş" harflerini bulup yuvarlak içine alalım.

• Noktaları birleştirelim.

Yazma yönüne dikkat ederek "Ş" harfini yazalım.



☞ "Ş" harfini yazalım.

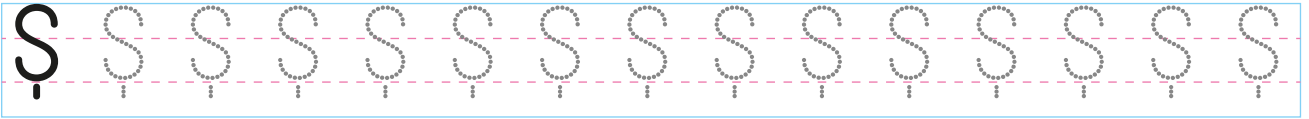
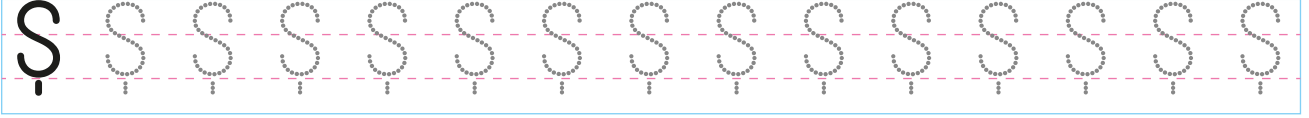
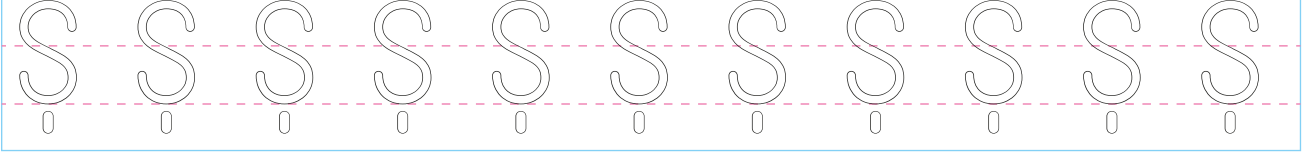



☞ Küçük "ş" harfinin yazılış yönüne dikkat edelim. İçinden kalemimizle geçelim.

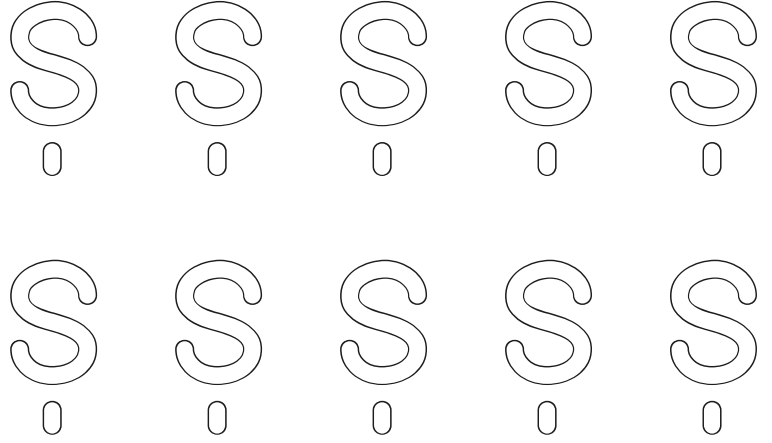
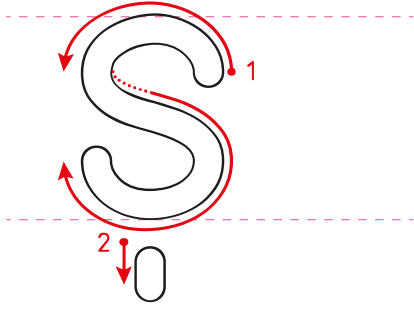

☞ "ş" harfinin yazılı olduğu yıldızları boyayalım.



Yönergeleri uygulayalım.

• "ş" harfini boyayalım.

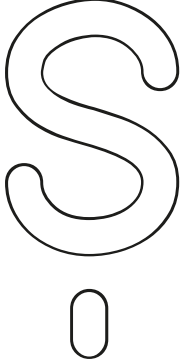

• "ş" harflerini bulup yuvarlak içine alalım.

ş ş k ü  
i k ş  
ş ş l o  
t t ş

• Noktaları birleştirelim.

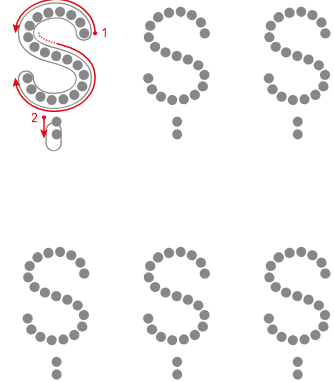

Yazma yönlerine dikkat ederek "ş" harfini yazalım.

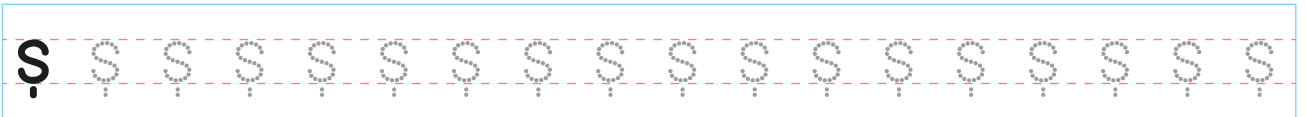
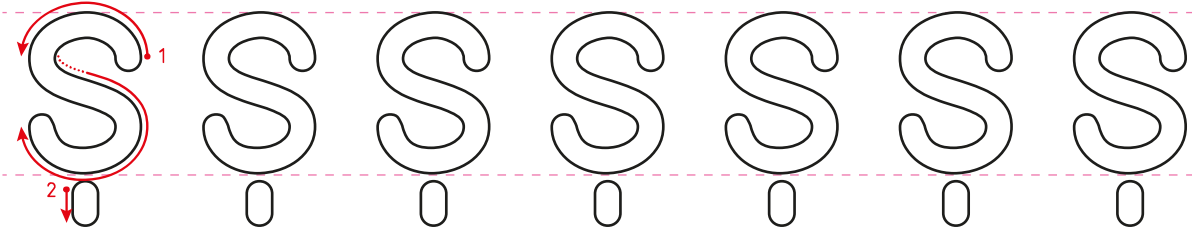



👉 "ş" harfini yazalım.

Ş Ş Ş Ş Ş Ş Ş Ş Ş Ş Ş Ş

Ş Ş Ş Ş Ş Ş Ş Ş Ş Ş Ş Ş Ş Ş Ş

Ş Ş Ş

Ş

Ş

Ş

Ş

Ş

Ş

Ş

Ş

Ş





👉 Büyük "Ş" ve küçük "ş" harfini yazalım.

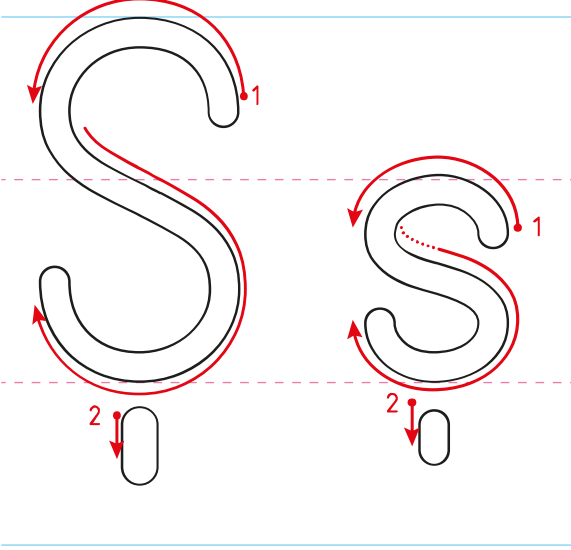



Okuyalım, yazalım.

e ş eş

ş e şe

a ş aş

ş a şa

i ş iş

ş i şi

o ş oş

ş o şo

eş ya eşya

Şe nay Şenay

Şenay eşya aldı.

aş ç aşçı

Şa kir Şakir

Şakir aşçı oldu.

iş ç işçi

şi ir şiir

İşçi şiir okudu.

şo k şok

şor t şort

Şoktan şort al.



Okuyalım, yazalım.

u ş uş

ş u şu

ü ş üş

ş ü şü

ö ş öş

ş ö şö

ı ş iş

ş ı şı

Mu ş Muş

du ş duş

Muşta duş al.

Şük ran Şükran

şu t şut

Şükran şut at.

köş k köşk

şö len şölen

Köşkte şölen oldu.

kı ş kış

şı k şık

Bu kış şık oldu.



👉 Kelimeleri okuyalım, yazalım.

diş

Handwriting practice box for the word "diş" with a yellow highlighted area for writing.

fiş

Handwriting practice box for the word "fiş" with a yellow highlighted area for writing.

kuş

Handwriting practice box for the word "kuş" with a yellow highlighted area for writing.

beş

Handwriting practice box for the word "beş" with a yellow highlighted area for writing.

aşı

Handwriting practice box for the word "aşı" with a yellow highlighted area for writing.

eşek

Handwriting practice box for the word "eşek" with a yellow highlighted area for writing.

ataş

Handwriting practice box for the word "ataş" with a yellow highlighted area for writing.

yeşil

Handwriting practice box for the word "yeşil" with a yellow highlighted area for writing.

beşik

Handwriting practice box for the word "beşik" with a yellow highlighted area for writing.

Şule

Handwriting practice box for the word "Şule" with a yellow highlighted area for writing.

Barış

Handwriting practice box for the word "Barış" with a yellow highlighted area for writing.

İşil

Handwriting practice box for the word "İşil" with a yellow highlighted area for writing.

Şeyma

Handwriting practice box for the word "Şeyma" with a yellow highlighted area for writing.

şeker

Handwriting practice box for the word "şeker" with a yellow highlighted area for writing.

şemsiye

Handwriting practice box for the word "şemsiye" with a yellow highlighted area for writing.

şişman

Handwriting practice box for the word "şişman" with a yellow highlighted area for writing.

beşik

Handwriting practice box for the word "beşik" with a yellow highlighted area for writing.

başarı

Handwriting practice box for the word "başarı" with a yellow highlighted area for writing.

şımarık

Handwriting practice box for the word "şımarık" with a yellow highlighted area for writing.

bitişik

Handwriting practice box for the word "bitişik" with a yellow highlighted area for writing.

arkadaş

Handwriting practice box for the word "arkadaş" with a yellow highlighted area for writing.

Ayşegül

Handwriting practice box for the word "Ayşegül" with a yellow highlighted area for writing.

başbakan

Handwriting practice box for the word "başbakan" with a yellow highlighted area for writing.



👉 Karışık hecelerden kelimeler oluşturup yazalım.

le la şe ▶

şik be taş ▶

mu yu şak ▶

müş ri te ▶

be şir te ▶

muş ku o ▶

ma rik şı ▶

şik ka rı ▶

ti bi şik ▶



☞ Cümleleri görsellerin adlarıyla tamamlayalım. Cümleleri okuyalım.



Büşra çorbayı ..... ile içmiş.



Daldaki ..... kaçmış.

5

Şeniz ..... tane turşu yemiş.



Dişi ..... yüzünden çürümüş.



Şule renkli ..... almış.



Dedem ..... ile inek almış.



☞ Cümleleri okuyalım. Okudukça yıldız boyayalım.



Şakir beş tane balon şişirdi.



Şensu geçen kış kursa başlamış.



Daldaki kuşları kaçırmış.



Şebnem teyzem turşu kurdu.



Büşra iki şişe taşır.



Şule akşam bize gelmiş.



Yaşar maçta şut atmış.



Şubat ayında maaş almış.



Şirin şaşkın şaşkın bakmış.



Yeşil ışık yandı, karşıya geç.



👉 Aynı rakamlarda yazılı kelimelerle cümleler oluşturup yazalım.

1 almış	2 çok	3 Ayşe
4 beş	3 yaktı	2 Şermin
5 almış	4 almış	1 Başak
2 koşuda	5 Şensu	4 kuruş
5 kışlık	5 kazak	4 Şenol
3 ışık	1 duş	2 yoruldu

1

2

3

4

5





👉 Metni okuyalım. Aşağıya yazalım.

## ŞANLI ATATÜRK

Anlı şanlı Atatürk

Yaşa yaşa sen çok yaşa

Şanlı Türk, Atatürk

Düşmana korku salmış

Bizlere neşe olmuş.



Blank writing area with a dashed line for tracing.

Blank writing area with a dashed line for tracing.

Blank writing area with a dashed line for tracing.

Blank writing area with a dashed line for tracing.

Blank writing area with a dashed line for tracing.

Blank writing area with a dashed line for tracing.



👉 Cümleleri okuyalım. Soruları cevaplayalım.

Şenay'a beş  
şeker aldı.

- Şenay'a ne aldı?

- Kaç şeker aldı?

İşıl yeşil şort giymiş.

- Ne renk şort giymiş?

- Yeşil şortu kim giymiş?

Şenol şemsiye açmış.

- Kim şemsiye açmış?

- Şenol ne açmış?

Şakir dışarıda  
üşümüş.

- Kim dışarıda üşümüş?

- Şakir nerede üşümüş?

Metini okuyalım. İstedığımız sonu işaretleyelim.

Şule bir şiir yazmış. Şiir Atatürk ile ilgiliymiş. Şule şiiri okulda okumuş.

- Arkadaşları onu alkışlamış.
- Şule çok mutlu olmuş.

Şükrü diş doktoruna gitmiş. Beş dişi çürükmüş. Doktor onu uyarmış. Dişlerini temiz tut demiş.

- Şükrü doktoru dinlememiş.
- Şükrü utanmış. Dişlerini temiz tutmuş.

Şenay bugün aşı oldu. Aşıdan korkmamış. Doktor onu kutlamış. Ona elma vermiş.

- Şenay, doktora teşekkür etmiş.
- Şenay çikolatayı yemiş.

Adında "c" sesi bulunan varlıkları boyayalım.

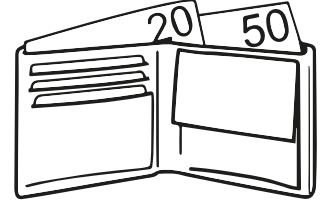
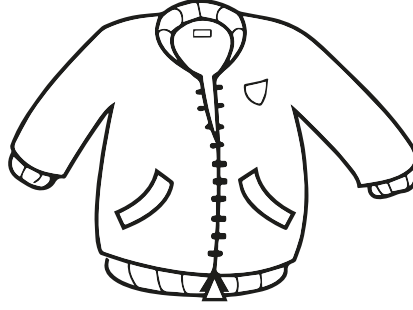
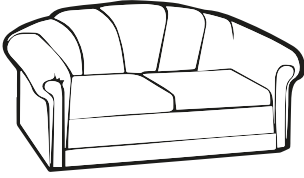
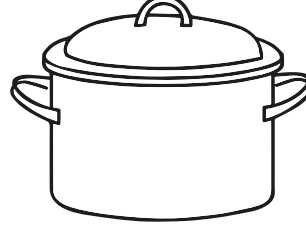
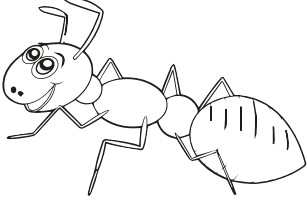

"c" sesi ile başlayan varlıkları işaretleyelim.

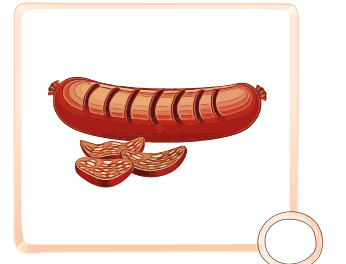
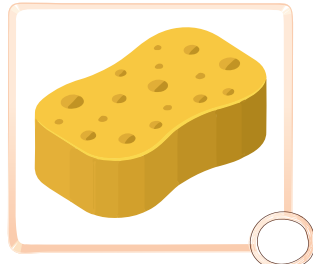
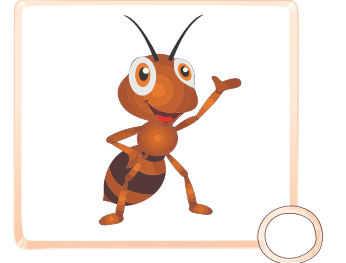
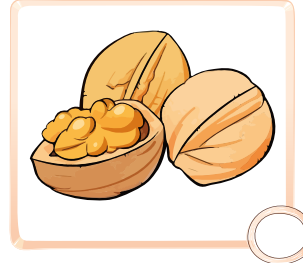
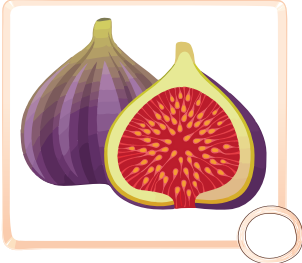
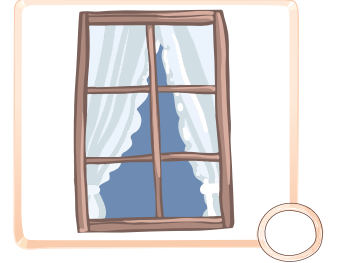
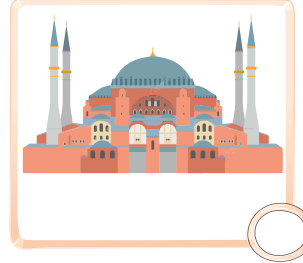
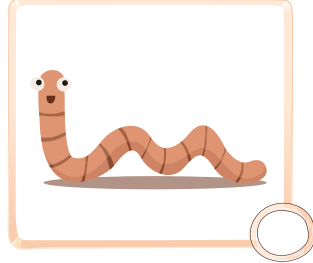

☞ Büyük "C" harfinin yazılış yönüne dikkat edelim. İçinden kalemimizle geçelim.

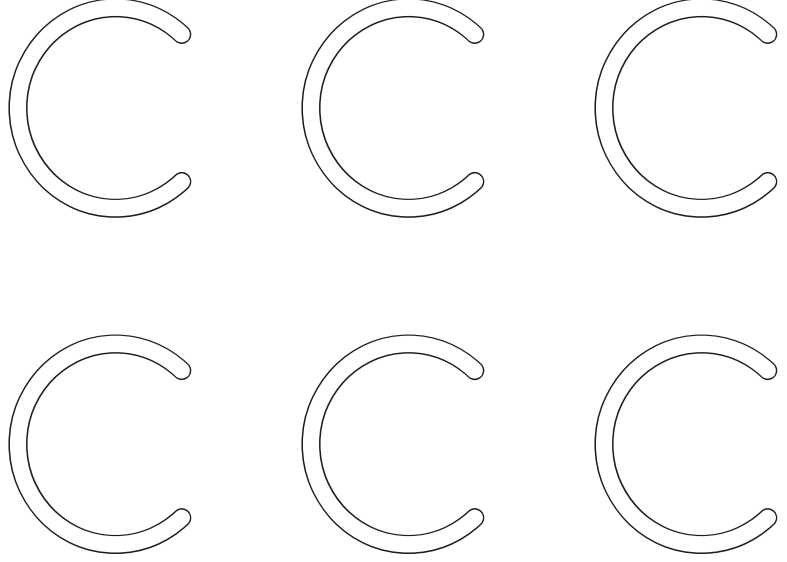
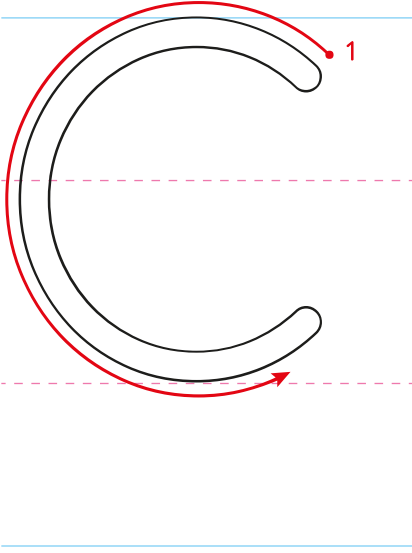

☞ "C" harfinin yazılı olduğu balonları boyayalım.

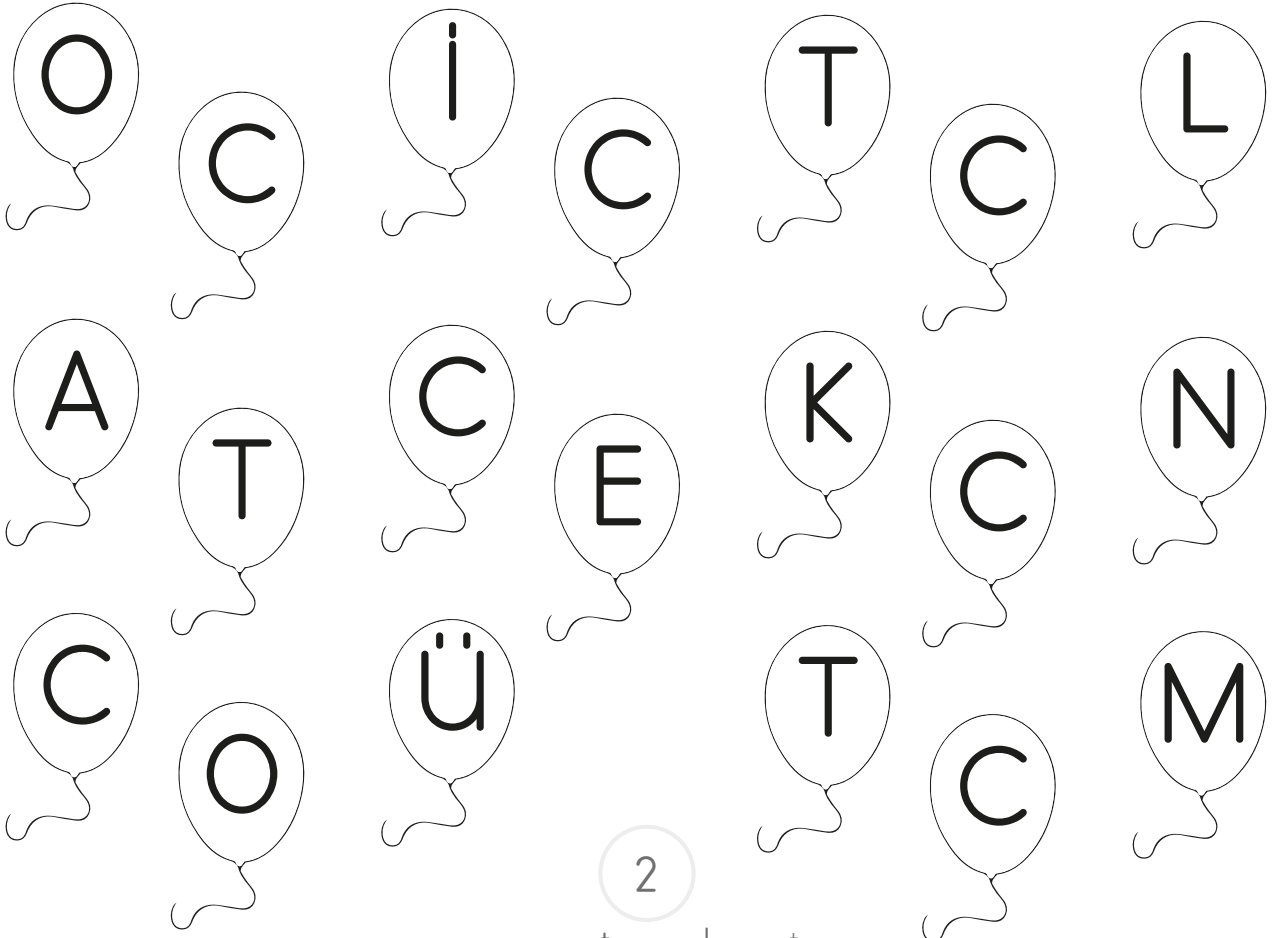

Yönergeleri uygulayalım.

- "C" harfini boyayalım.

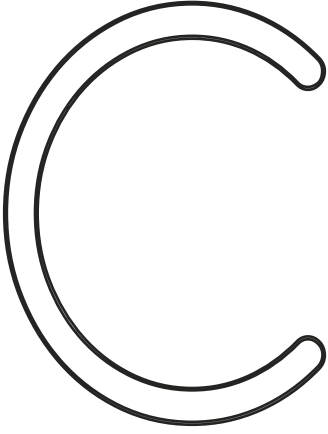

- "C" harflerini bulup yuvarlak içine alalım.

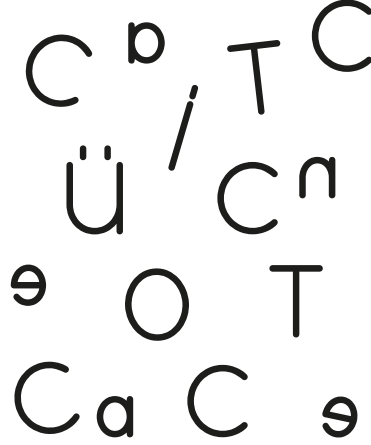

- Noktaları birleştirelim.

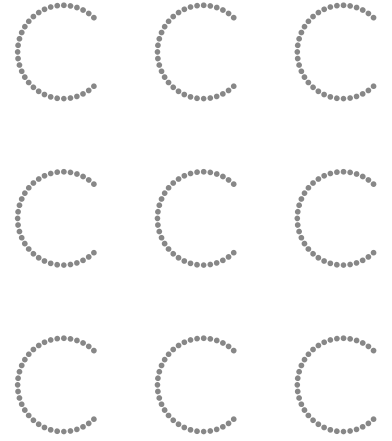

Yazma yönüne dikkat ederek "C" harfini yazalım.

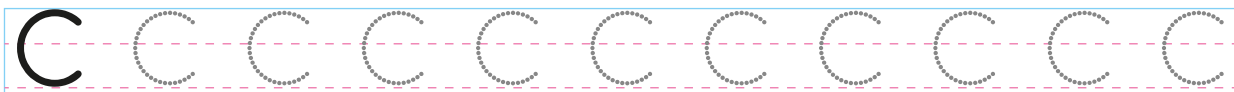
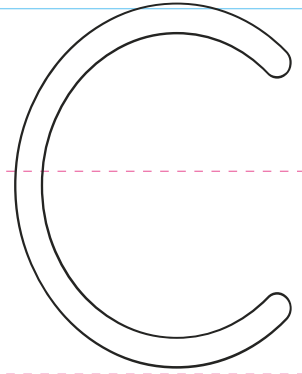
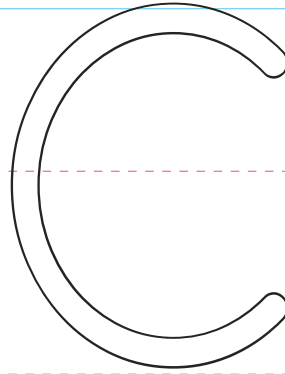
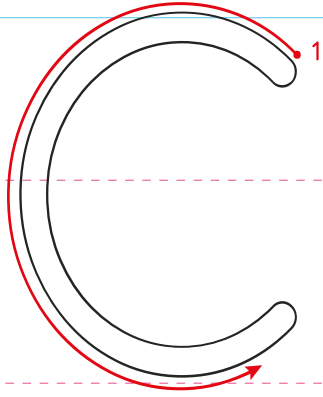



☞ "C" harfini yazalım.

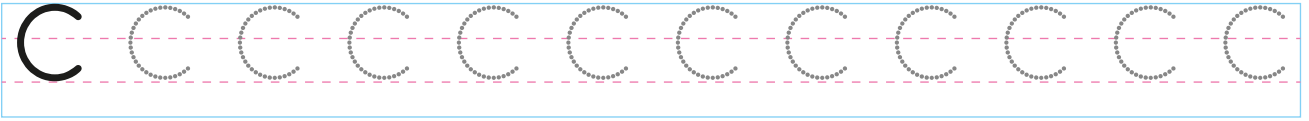
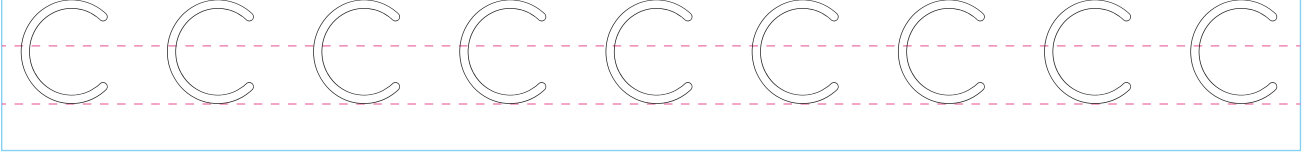



☞ Küçük "c" harfinin yazılış yönüne dikkat edelim. İçinden kalemimizle geçelim.

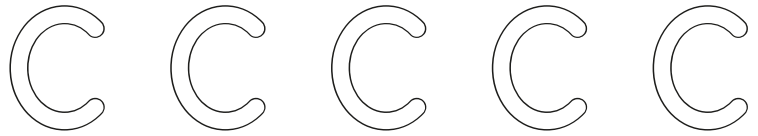
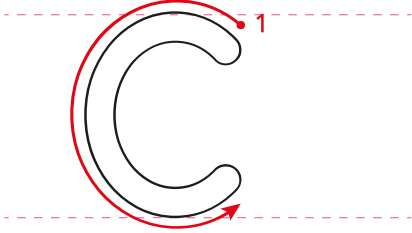
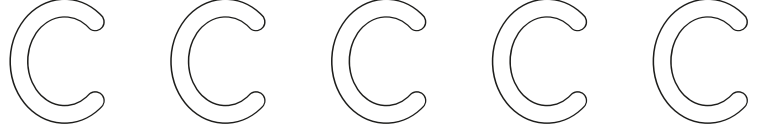

☞ "c" harfinin yazılı olduğu yıldızları boyyalım.

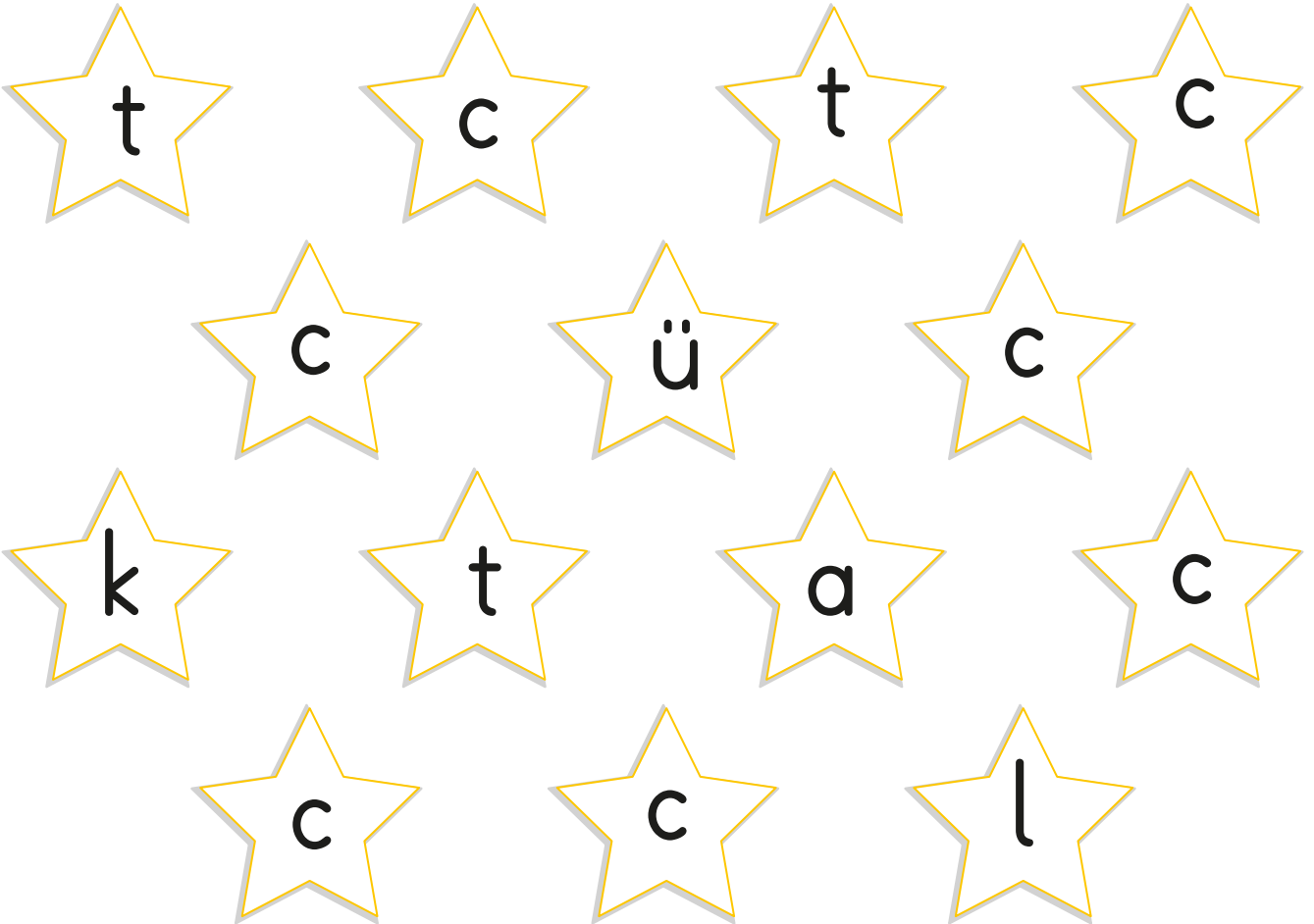



Yönergeleri uygulayalım.

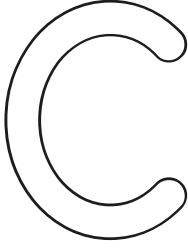

• "c" harfini boyayalım.



• "c" harflerini bulup yuvarlak içine alalım.

b c c ü  
i k i k c  
c c l o  
t t c

• Noktaları birleştirelim.



Yazma yönlerine dikkat ederek "c" harfini yazalım.

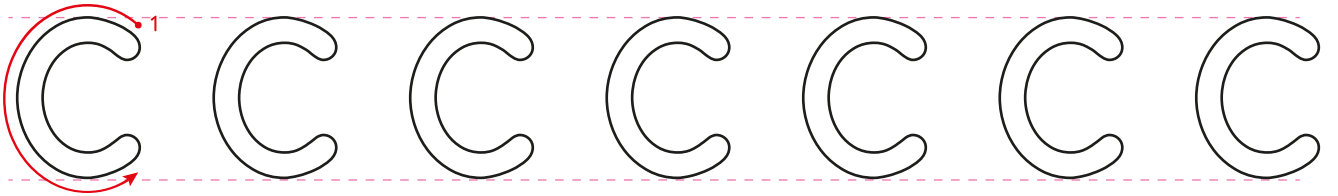



☞ "c" harfini yazalım.

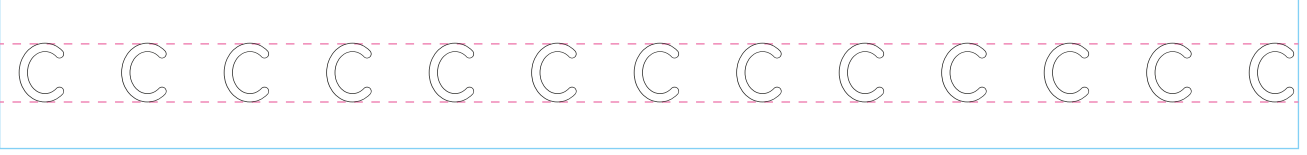



👉 Büyük "C" ve küçük "c" harfini yazalım.

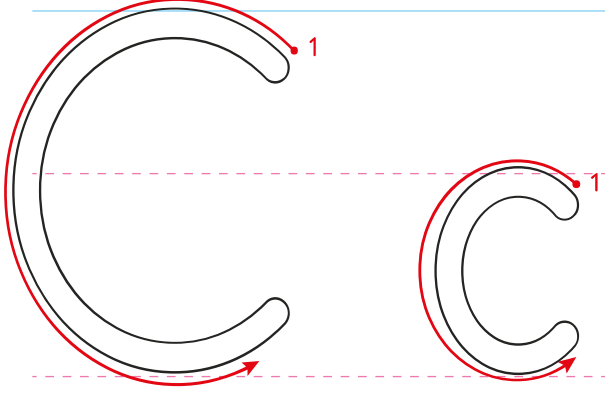



Okuyalım, yazalım.

e c ec

c e ce

a c ac

c a ca

i c ic

c i ci

o c oc

c o co

E ce Ece

ge ce gece

Ece gece geldi.

Ca n Can

ri ca rica

Can rica etti.

ci la cila

İn ci İnci

İnci onu cilaladı.

co ş coş

Coş kun Coşkun

Coşkun coştı.



u c uc

c u cu

ü c üc

c ü cü

ö c öc

c ö cö

ı c ic

c ı ci

cu ma cuma

su cu sucu

Cuma günü bize sucu geldi.

cü ce cüce

ö cü öcü

Cüce öcü dedi.

Ce m Cem

cö mert cömert

Cem cömert biri.

cı k cık

ca cık cacık

Ece cacık yer.



☞ Kelimeleri okuyalım, yazalım.

Can

Handwriting practice box for the word "Can".

Cem

Handwriting practice box for the word "Cem".

Ece

Handwriting practice box for the word "Ece".

Cenk

Handwriting practice box for the word "Cenk".

cam

Handwriting practice box for the word "cam".

acı

Handwriting practice box for the word "acı".

baca

Handwriting practice box for the word "baca".

cadı

Handwriting practice box for the word "cadı".

ceza

Handwriting practice box for the word "ceza".

sıcak

Handwriting practice box for the word "sıcak".

böcek

Handwriting practice box for the word "böcek".

sucuk

Handwriting practice box for the word "sucuk".

ciddi

Handwriting practice box for the word "ciddi".

Ceren

Handwriting practice box for the word "Ceren".

Cemal

Handwriting practice box for the word "Cemal".

Cemil

Handwriting practice box for the word "Cemil".

Gonca

Handwriting practice box for the word "Gonca".

çocuk

Handwriting practice box for the word "çocuk".

ciklet

Handwriting practice box for the word "ciklet".

cimri

Handwriting practice box for the word "cimri".

yolcu

Handwriting practice box for the word "yolcu".

Cemre

Handwriting practice box for the word "Cemre".

önce

Handwriting practice box for the word "önce".

yüce

Handwriting practice box for the word "yüce".

yonca

Handwriting practice box for the word "yonca".



👉 Karışık hecelerden kelimeler oluşturup yazalım.

ki	es	ci	▶	
o	cu	dun	▶	
cu	yun	o	▶	
ce	lik	ge	▶	
Bi	cik	le	▶	
ca	ka	rın	▶	

👉 Karışık kelimelerden cümleler oluşturup yazalım.

camları    kirli    sildi    Ceren

ile    oynadı    Ece    oyuncakları

reçeli    incir    yedi    Can



☞ Cümleleri görseli ile eşleştirelim.

Cengiz maçta kaleci oldu.



Cici kuş gece çok öttü.



Cumartesi günü Ceren geldi.



Canan mercimek çorbası içti.



Cemil yarışta birinci oldu.



Gece karnı çok acıkmış.



Cem amcam sucuk kızarttı.



Ceyda yemekte cacık yedi.







Metni okuyalım. Aşağıya yazalım.

## SALINCAK

Ece ile Can salıncak kurdu.

Önce Ece Can'ı salladı.

Sonra Can Ece'yi salladı.

Güzel sıcak bir gündü.

Salıncakta cici cici sallandılar.



Empty box for writing the first line of the text.

Empty box for writing the second line of the text.

Empty box for writing the third line of the text.

Empty box for writing the fourth line of the text.

Empty box for writing the fifth line of the text.

Empty box for writing the sixth line of the text.



👉 Metini okuyalım. Soruları cevaplayalım.

## GONCA

Gonca'nın karnı acıktı. Yemekte mercimek yedi. Canı cacık istedi. Sonra cacık da yedi. Annesi incir yıkadı. Gonca inciri de yedi. Karnını güzelce doyurdu. Annesine teşekkür etti.

1. Kimin karnı acıktı?

2. Gonca yemekte neler yedi?

3. Annesi ne yıkadı?

4. Gonca karnını nasıl doyurdu?



☞ Verilen görsellerle ilgili birer cümle yazalım.



Handwriting practice line with a dashed middle line.



Handwriting practice line with a dashed middle line.



Handwriting practice line with a dashed middle line.



Handwriting practice line with a dashed middle line.



Handwriting practice line with a dashed middle line.



Handwriting practice line with a dashed middle line.

👉 Adında "p" sesi bulunan varlıkları boyayalım.

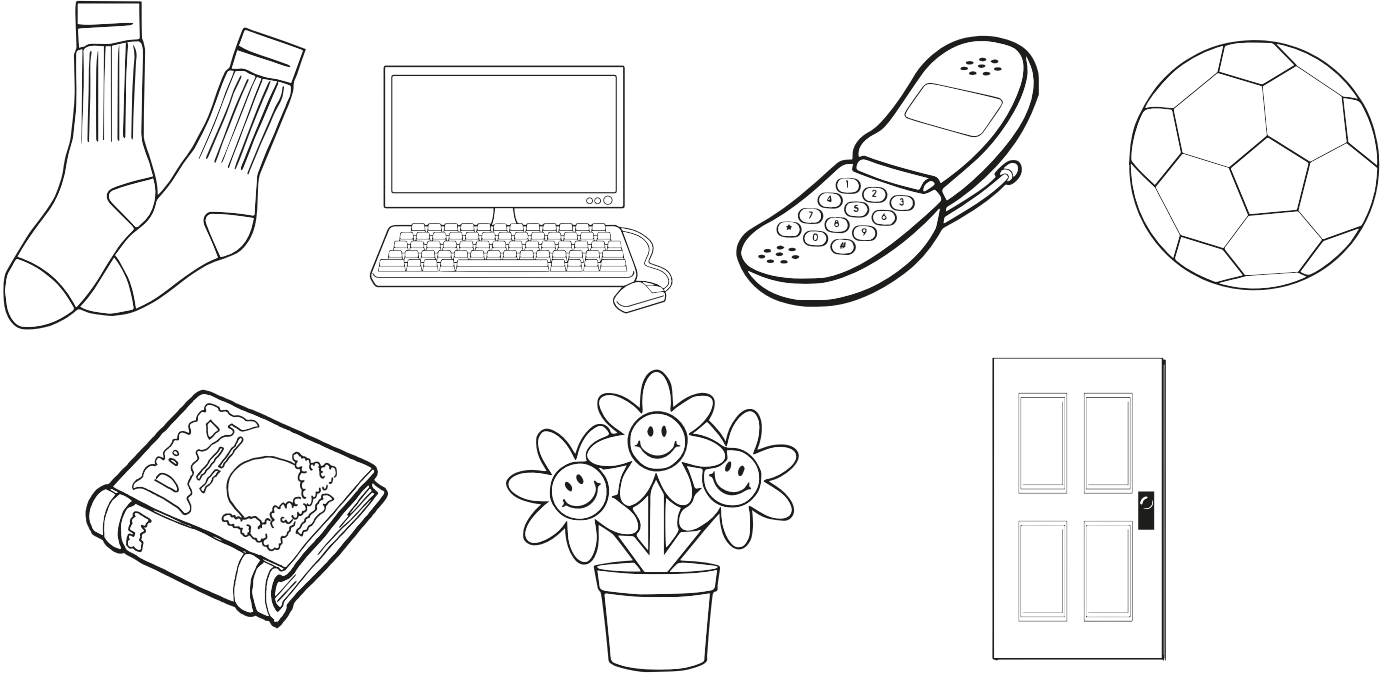

👉 "p" sesi ile başlayan varlıkları işaretleyelim.



☞ Büyük "P" harfinin yazılış yönüne dikkat edelim. İçinden kalemimizle geçelim.

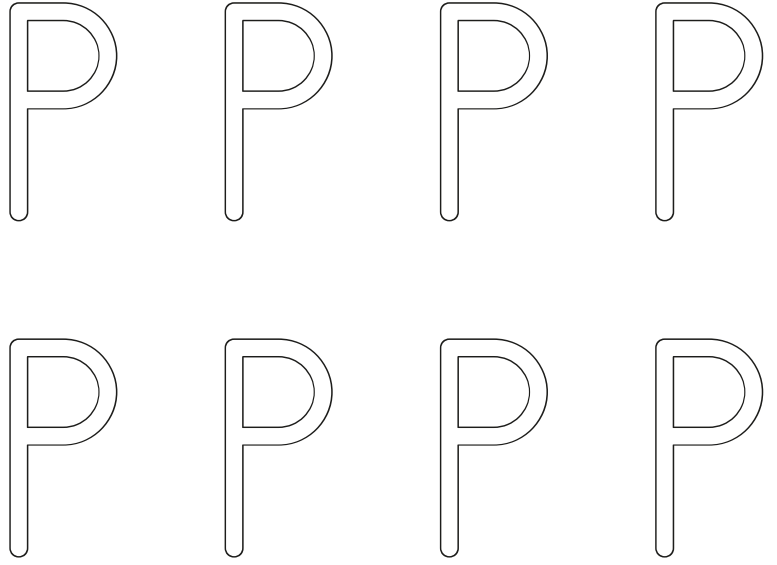
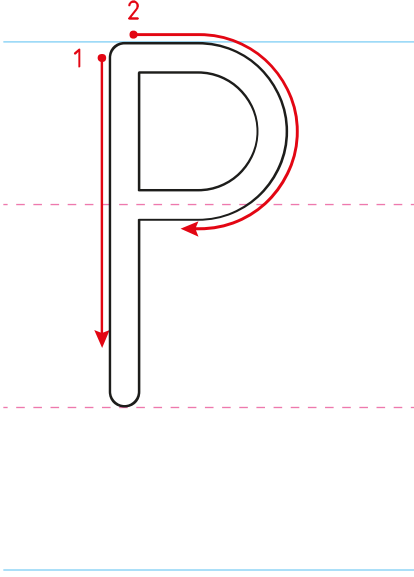

☞ "P" harfinin yazılı olduğu balonları boyayalım.

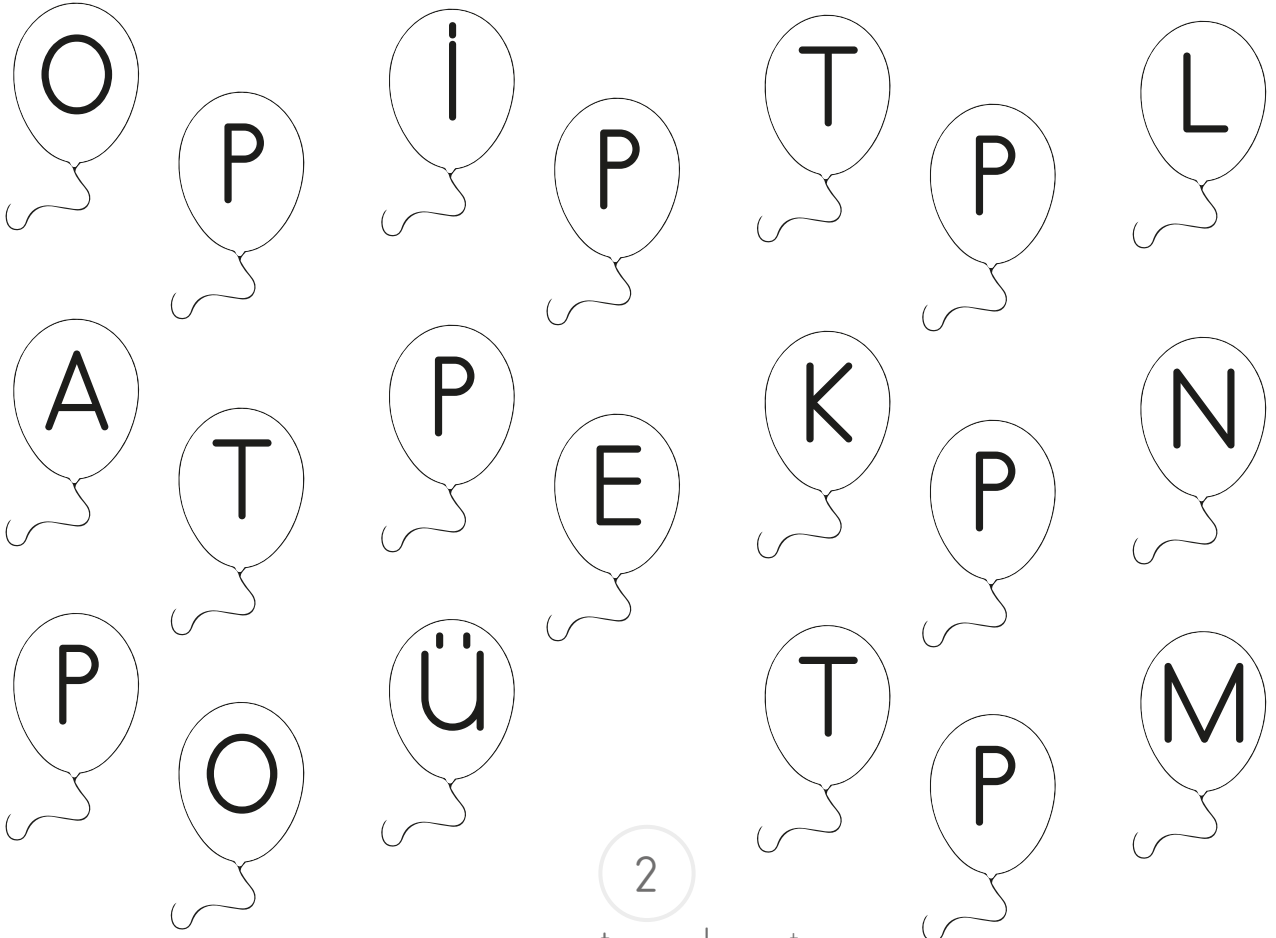

Yönergeleri uygulayalım.

• "P" harfini boyayalım.

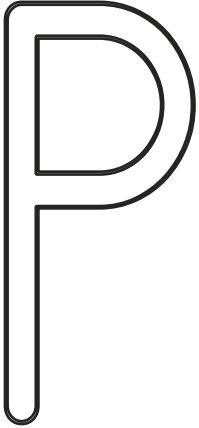

• "P" harflerini bulup yuvarlak içine alalım.

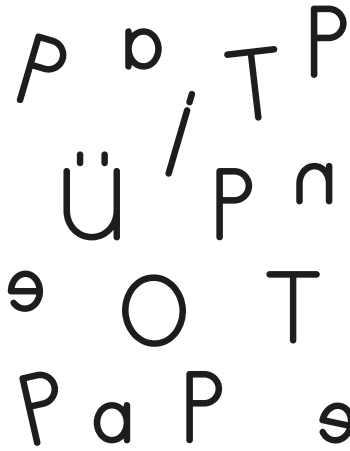

• Noktaları birleştirelim.

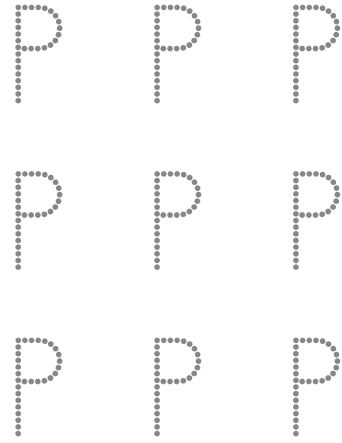

Yazma yönüne dikkat ederek "P" harfini yazalım.

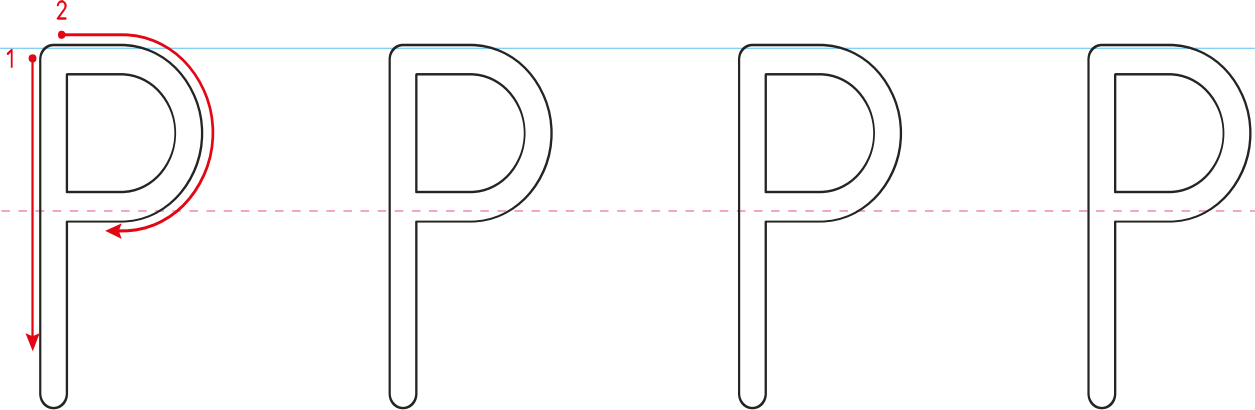



☞ "P" harfini yazalım.

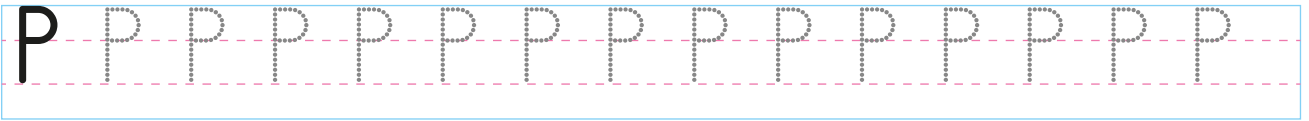
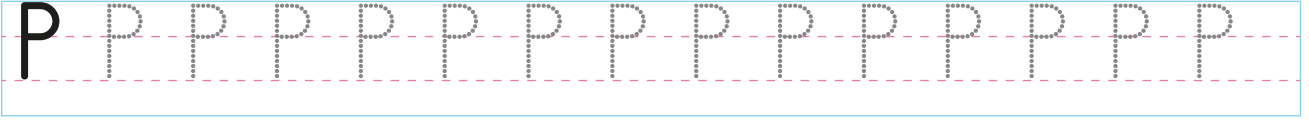
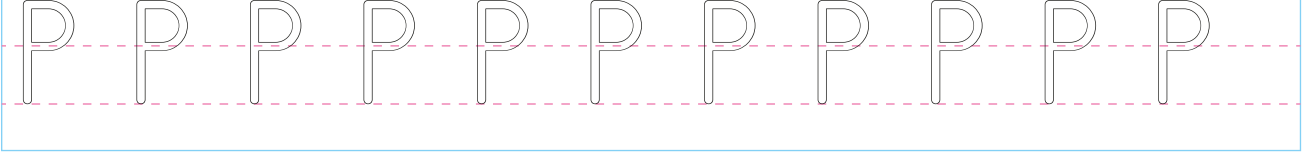

☞ Küçük "p" harfinin yazılış yönüne dikkat edelim. İçinden kalemimizle geçelim.

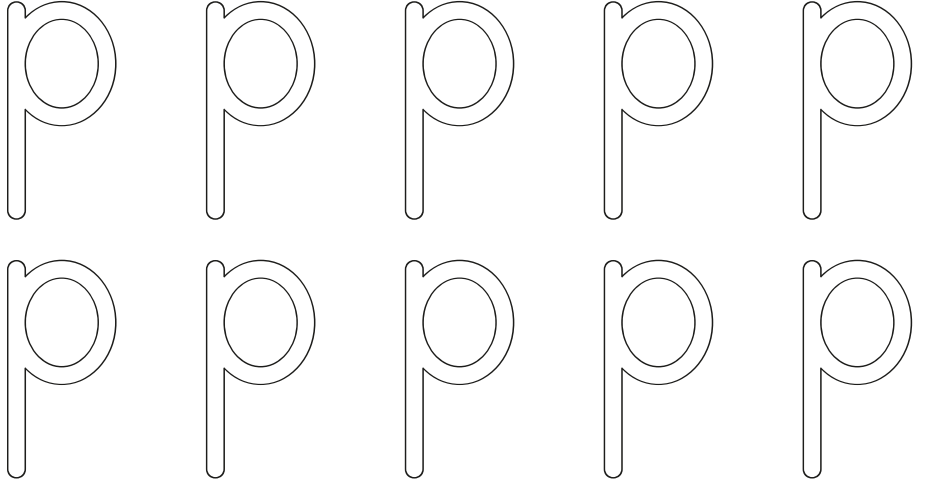
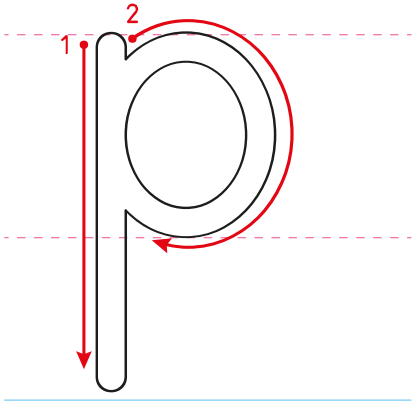

☞ "p" harfinin yazılı olduğu yıldızları boyayalım.





Yönergeleri uygulayalım.

• "p" harfini boyayalım.

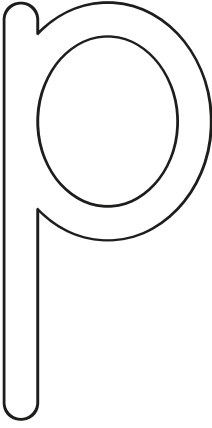

• "p" harflerini bulup yuvarlak içine alalım.

p p k ü  
i k p  
p p l o  
t t p

• Noktaları birleştirelim.

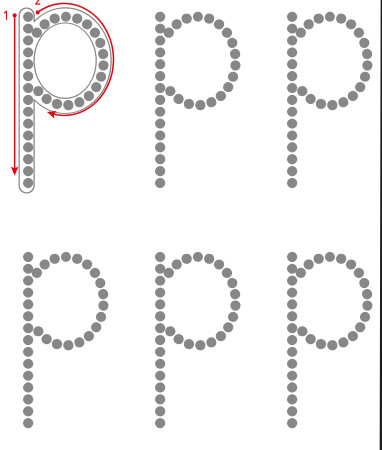

Yazma yönlerine dikkat ederek "p" harfini yazalım.

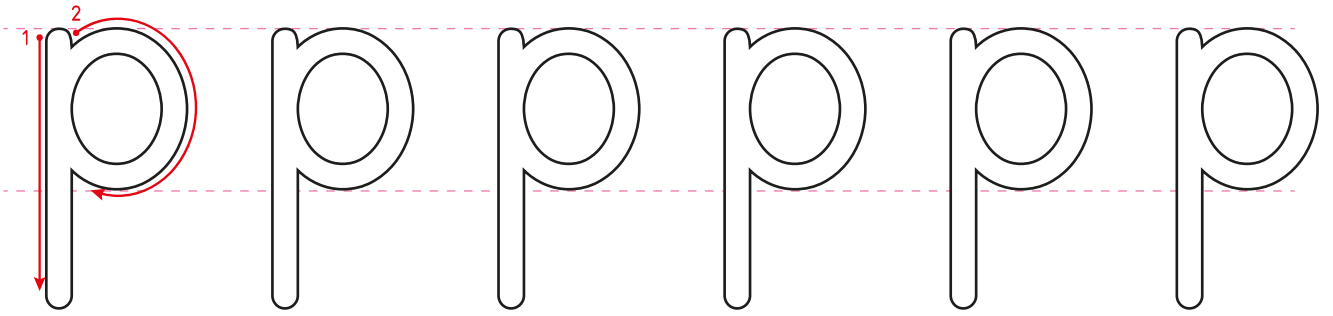



☞ "p" harfini yazalım.

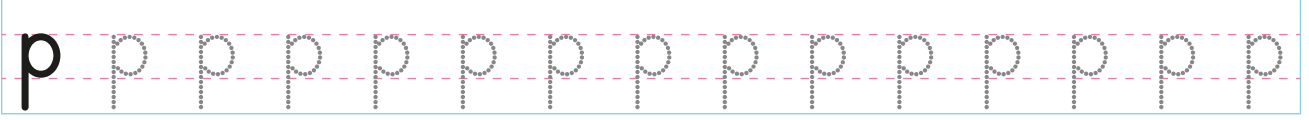
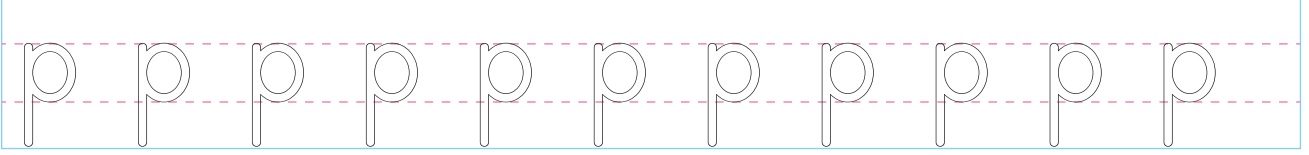



👉 Büyük "P" ve küçük "p" harfini yazalım.

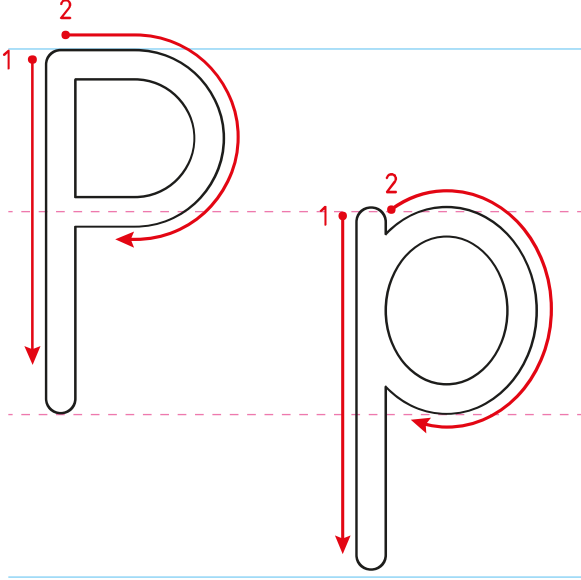

P P P P P P P P

P P P

P

P

P P

p p p p p

p p p p

p

p

p

p



Okuyalım, yazalım.

e p ep

p e pe

a p ap

p a pa

i p ip

p i pi

o p op

p o po

Pe lin Pelin

te pe tepe

Pelin tepeye gitti.

pa ra para

pa no pano

Panodan para al.

pi lot pilot

pi de pide

Pilot pide yedi.

Po lat Polat

po ta pota

Polat potaya at.



Okuyalım, yazalım.

u p up p u pu

ü p üp p ü pü

ö p öp p ö pö

ı p ip p ı pı

pu an puan to pu topu

Topu al, puan al.

pü re püre pü rüz pürüz

Püre pürüzlü.

öp tü öptü öp müş öpmüş

Annesi öptü.

Pı nar Pınar ka pı kapı

Pınar kapıyı aç.



☞ Cümleleri okuyalım. Okudukça yıldız boyayalım.



Pırıl, Polat'ın topunu patlattı.



Pelin teyzem pirinç ayıklıyor.



Pazardan karpuz, ıspanak aldık.



Recep peynirli pide sever.



İpek kırlarda papatya topladı.



Pembe ip ile pamuk alır mısın?



Serpil yeni küpe taktı.



Annemle peynirli pizza yaptık.



Zeynep akşam kitap okur.



Poyraz patates püresi yaptı.



👉 Aynı şeklin içindeki kelimelerle cümle oluşturalım. Cümleleri yazalım.

günü

kremalı

yaptı

kupa

Serpil

pembe

tuttu

posta

kazandı

geldi

pasta

Alper

yaptı

perdeye

pazartesi

püskül

Alpay

topu

Blank writing line with a dashed red line for the middle and a solid blue line for the bottom.

Blank writing line with a dashed red line for the middle and a solid blue line for the bottom.

Blank writing line with a dashed red line for the middle and a solid blue line for the bottom.

Blank writing line with a dashed red line for the middle and a solid blue line for the bottom.

Blank writing line with a dashed red line for the middle and a solid blue line for the bottom.



👉 Cümleleri okuyalım. Soruları cevaplayalım.

Pınar pidecide  
Alper'i gördü.

• Kim gördü?

• Nerede gördü?

• Kimi gördü?

İpek patatesi  
küp küp kesti.

• Kim kesti?

• Neyi kesti?

• Nasıl kesti?

Poyraz topu  
potaya attı.

• Kim attı?

• Neyi attı?

• Nereye attı?

Pazar günü Pelin  
piknik yaptı.

• Ne zaman yaptı?

• Kim yaptı?

• Ne yaptı?



Metni okuyalım.

## PAZAR

Babama çorap aldık.  
Sonra kasaptan kıyma  
aldık. Yolda Pelin'e  
rastladık. Pelin pembe  
toka almış. Pembe toka  
ona yakışmış.

Metne uygun bir resim çizelim.

Soruları cevaplayalım.

1. Babasına ne  
almışlar?

2. Kasaptan ne  
almışlar?

3. Yolda kime  
rastlamışlar?



☞ Metni önce bir kez okuyalım. Sonra süre tutarak okuyalım. Bir dakikada kaç kelime okuduğumuzu tabloya yazalım.

## ALPAY KİTAPÇIDA

Alpay para topladı. Kitap almak istiyordu. Pırıl teyzesi gelince ona söyledi. Birlikte kitapçıya gittiler. Alpay, "Pinokyo" kitabını istedi. Kitapçı kitabı Alpay'a uzattı. Alpay da ona paraları uzattı. Parası yetmemişti. Pırıl teyzesi de para ekledi. Kitap Alpay'ın olmuştu. Alpay kitapçıdan çıkarken Pırıl teyzesine sarıldı. Ona teşekkür etti.

	Süre	Kelime Sayısı
1. Okuma	1 dakika	..... kelime
2. Okuma	1 dakika	..... kelime
3. Okuma	1 dakika	..... kelime



# MATEMATİK

1

2

3

4

5

6

7

8

+

-

9

0

÷



×

=



?

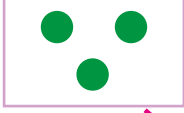

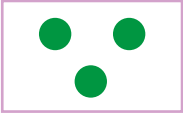

👉 Modellenen işlemleri örnekteki gibi yapalım.

   $\Rightarrow$   $3 + 2 = 5$



   $\Rightarrow$   $2 + 3 = 5$



   $\Rightarrow$   $\dots + \dots = \dots$

   $\Rightarrow$   $\dots + \dots = \dots$

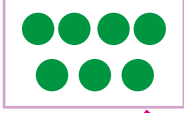
   $\Rightarrow$   $\dots + \dots = \dots$

   $\Rightarrow$   $\dots + \dots = \dots$

   $\Rightarrow$   $\dots + \dots = \dots$

   $\Rightarrow$   $\dots + \dots = \dots$

👉 Toplama işlemlerini yapalım. Toplananların yerlerini değiştirerek işlemleri yeniden yapalım.

$$4 + 2 = \dots 6 \dots$$

$$\dots 2 \dots + \dots 4 \dots = \dots 6 \dots$$

$$7 + 3 = \dots \dots \dots$$

$$\dots \dots + \dots \dots = \dots \dots \dots$$

$$3 + 2 = \dots \dots \dots$$

$$\dots \dots + \dots \dots = \dots \dots \dots$$

$$6 + 1 = \dots \dots \dots$$

$$\dots \dots + \dots \dots = \dots \dots \dots$$

$$8 + 4 = \dots \dots \dots$$

$$\dots \dots + \dots \dots = \dots \dots \dots$$

$$5 + 7 = \dots \dots \dots$$

$$\dots \dots + \dots \dots = \dots \dots \dots$$

$$1 + 8 = \dots \dots \dots$$

$$\dots \dots + \dots \dots = \dots \dots \dots$$

$$4 + 6 = \dots \dots \dots$$

$$\dots \dots + \dots \dots = \dots \dots \dots$$

$$2 + 7 = \dots \dots \dots$$

$$\dots \dots + \dots \dots = \dots \dots \dots$$

$$9 + 3 = \dots \dots \dots$$

$$\dots \dots + \dots \dots = \dots \dots \dots$$

$$6 + 5 = \dots \dots \dots$$

$$\dots \dots + \dots \dots = \dots \dots \dots$$

$$3 + 10 = \dots \dots \dots$$

$$\dots \dots + \dots \dots = \dots \dots \dots$$

☞ Toplama işlemlerini yapalım. Toplananların yerlerini değiştirerek işlemleri yeniden yapalım.

$\begin{array}{r} 6 \\ + 2 \\ \hline \end{array}$ <p>.....</p> <p>.....</p>	$\begin{array}{r} 8 \\ + 6 \\ \hline \end{array}$ <p>.....</p> <p>.....</p>
$\begin{array}{r} 9 \\ + 5 \\ \hline \end{array}$ <p>.....</p> <p>.....</p>	$\begin{array}{r} 7 \\ + 4 \\ \hline \end{array}$ <p>.....</p> <p>.....</p>
$\begin{array}{r} 8 \\ + 5 \\ \hline \end{array}$ <p>.....</p> <p>.....</p>	$\begin{array}{r} 3 \\ + 9 \\ \hline \end{array}$ <p>.....</p> <p>.....</p>
$\begin{array}{r} 6 \\ + 0 \\ \hline \end{array}$ <p>.....</p> <p>.....</p>	$\begin{array}{r} 8 \\ + 9 \\ \hline \end{array}$ <p>.....</p> <p>.....</p>



İşlemlerin eşit olması için noktalı yerlere uygun sayılar yazalım.

$7+5=.....+7$	$4+8=8+.....$	$3+.....=7+3$
$9+.....=2+9$	$.....+1=1+6$	$7+4=4+.....$
$.....+8=8+10$	$7+.....=12+7$	$2+14=.....+2$
$6+11=11+.....$	$.....+3=3+15$	$12+...=8+12$
$.....+1=14+1$	$8+.....=6+8$	$7+9=.....+7$
$12+...=0+12$	$.....+2=2+11$	$5+4=4+.....$



☞ Sonucu birbirine eşit olan işlemleri kesip yapıştıralım.



$4+2$

$12+5$

$9+4$

$8+6$

$3+2$

$1+9$

$6+4$

$7+5$

$12+7$

$10+8$

$6+5$

$5+7$

$2+3$

$2+4$

$4+9$

$5+12$

$8+10$

$9+1$

$7+12$

$5+6$

$\square = \square$

$\square = \square$

$\square = \square$

$\square = \square$

$\square = \square$

$\square = \square$

$\square = \square$

$\square = \square$

$\square = \square$

$\square = \square$



👉 Eşit olan işlemlerde noktalı yere gelecek sayıyı bulalım. Bulmayaca yazalım.

a-  $2 + 17 = \dots + 2$

f-  $8 + \dots = 1 + 8$

b-  $8 + \dots = 7 + 8$

g-  $6 + 3 = 3 + \dots$

c-  $\dots + 4 = 13 + 4$

ğ-  $2 + 4 = \dots + 2$

ç-  $10 + 4 = \dots + 10$

h-  $12 + 5 = \dots + 12$

d-  $\dots + 8 = 8 + 3$

ı-  $\dots + 13 = 13 + 2$

e-  $7 + \dots = 9 + 7$

i-  $1 + \dots = 8 + 1$

a

c

ç

d

ğ

ı

b

e

f

g



İstedığımız  
meyvelerden  
kendimize  
taç yapalım.

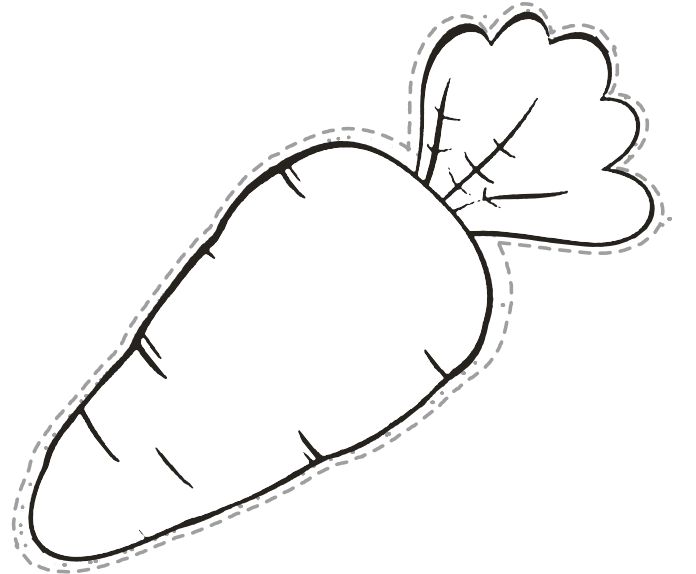
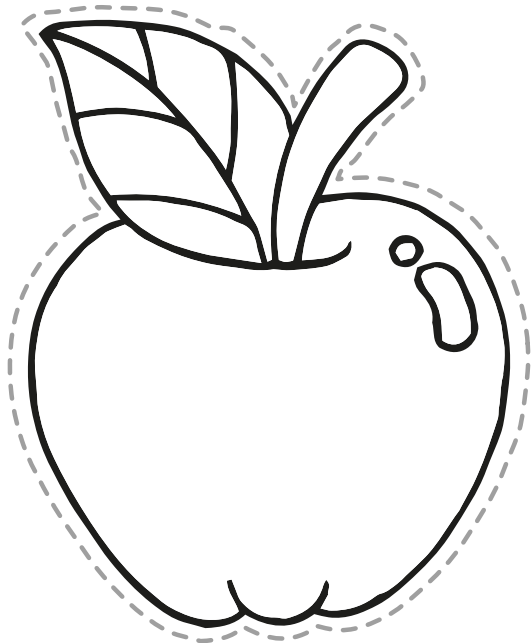
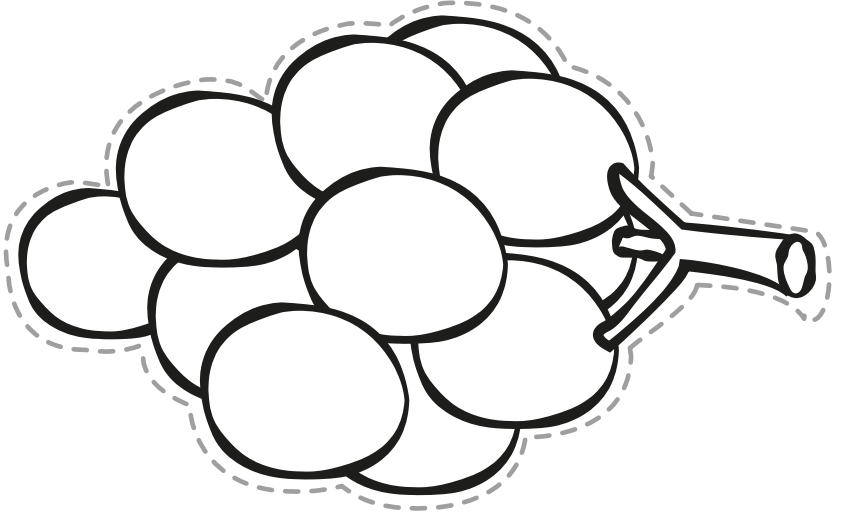
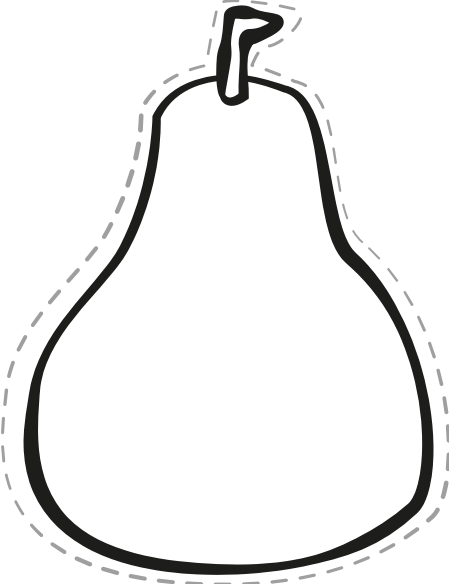

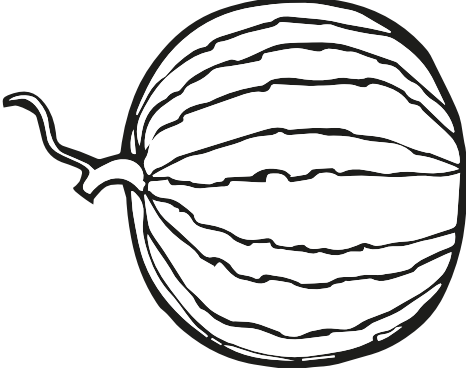

Y



M

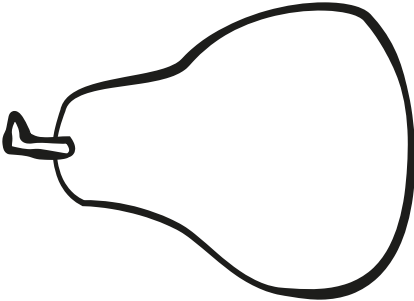
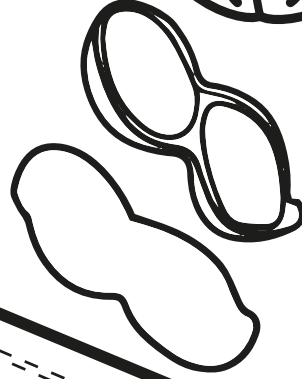

R

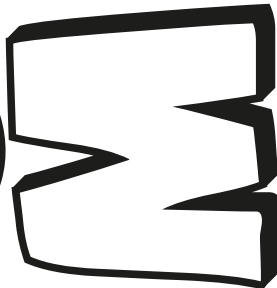
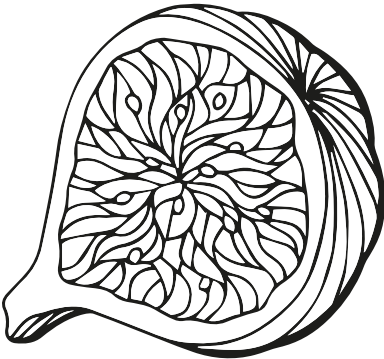
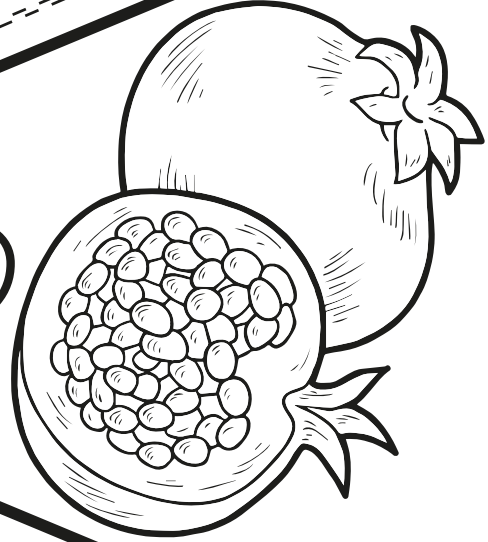
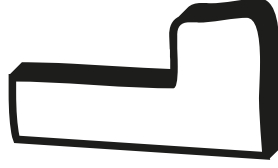
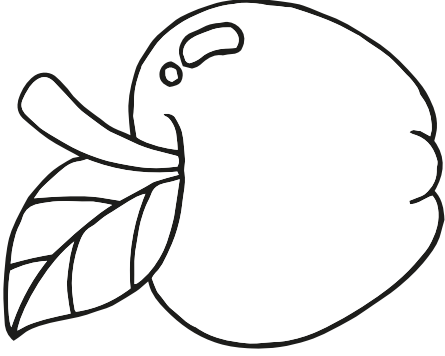

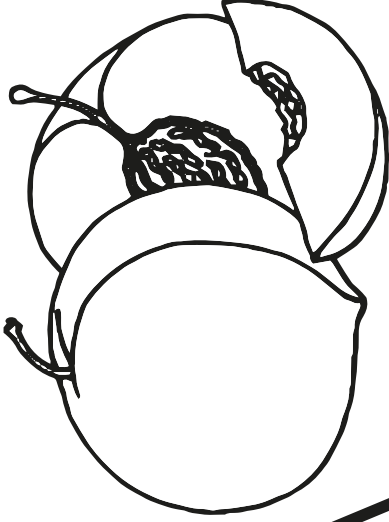

A

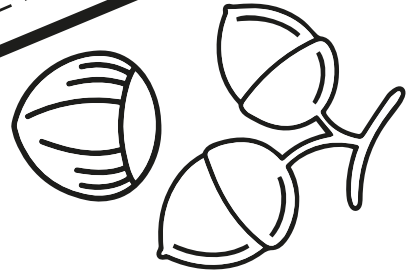

Y

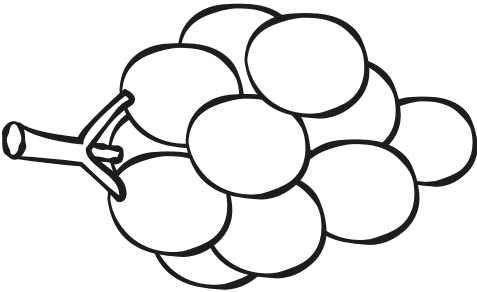
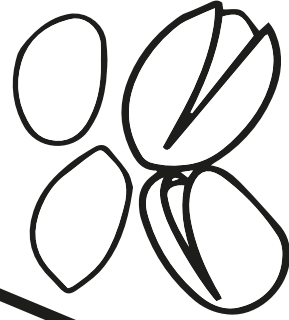

U