

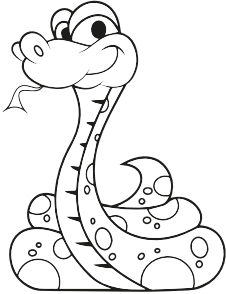

# I VE D SESİ ÇALIŞMALARI

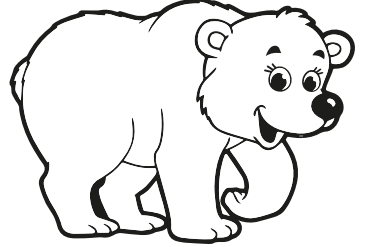

👉 Adında "i" sesi bulunan varlıkları boyayalım.

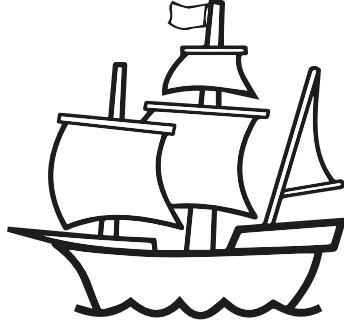
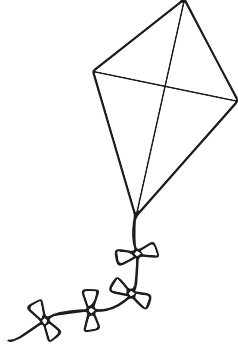
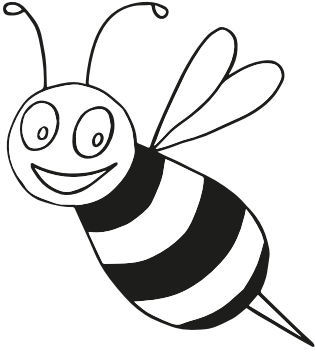

👉 "i" sesi ile başlayan varlıkları işaretleyelim.

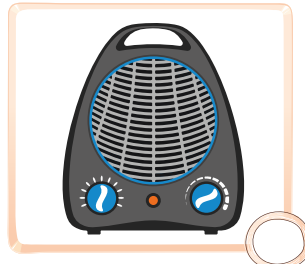
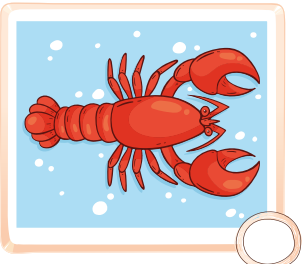
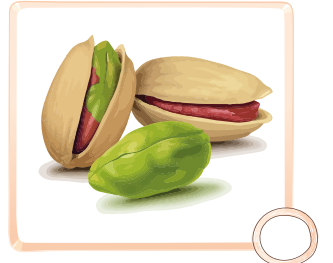
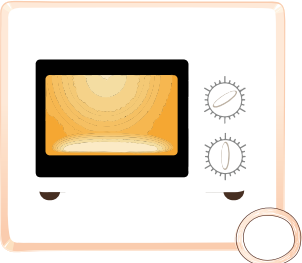
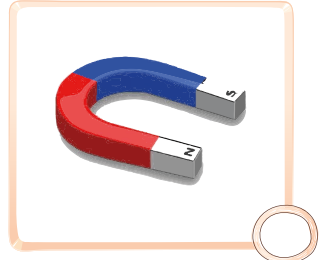
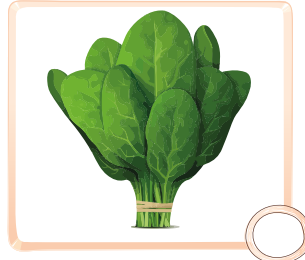
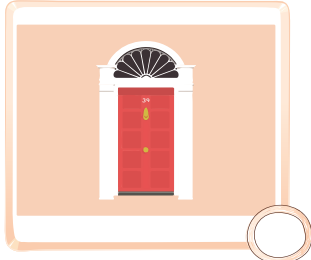
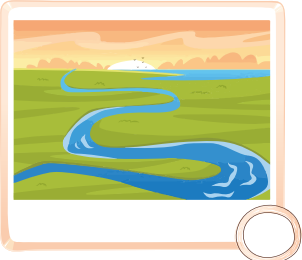

☞ Büyük "I" harfinin yazılış yönüne dikkat edelim. İçinden kalemimizle geçelim.

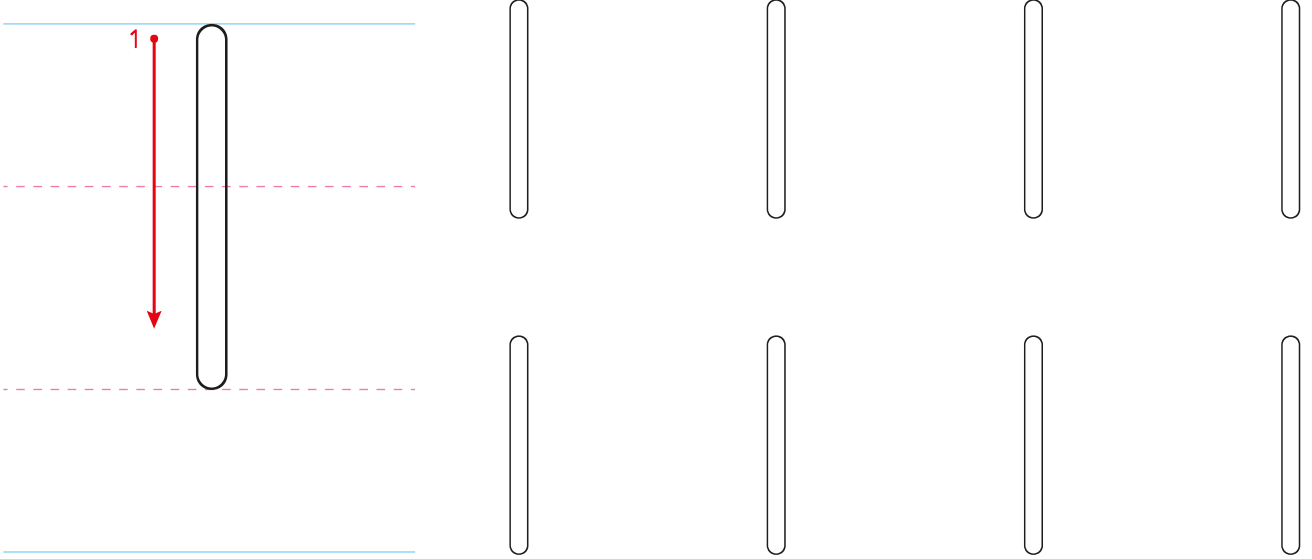

☞ "I" harfinin yazılı olduğu balonları boyayalım.

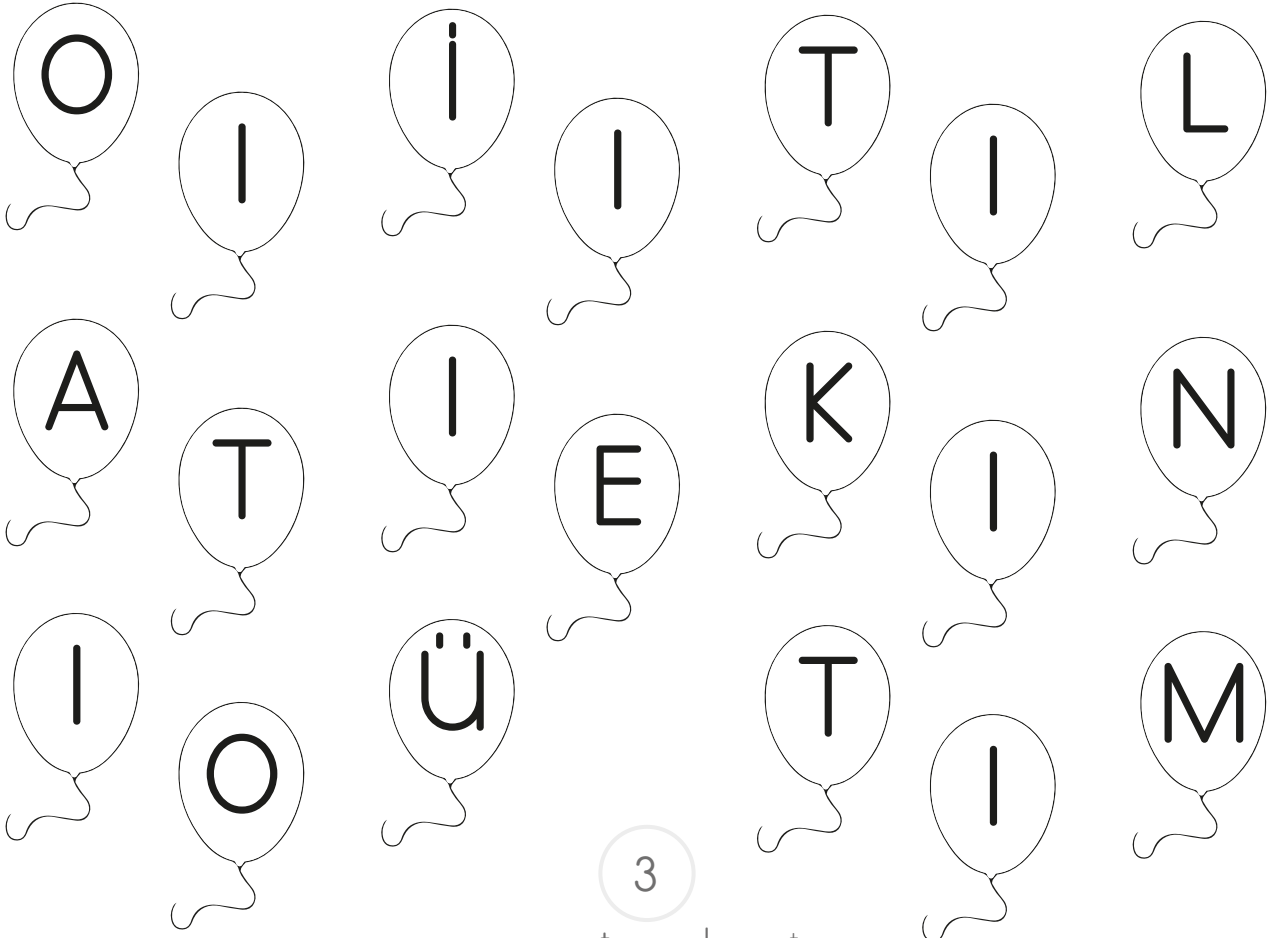

Yönergeleri uygulayalım.

• "I" harfini boyayalım.

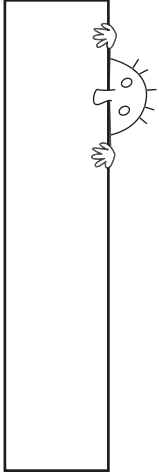

• "I" harflerini bulup yuvarlak içine alalım.

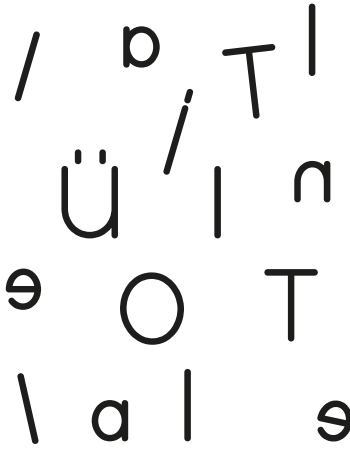

• Noktaları birleştirelim.



Yazma yönüne dikkat ederek "I" harfini yazalım.

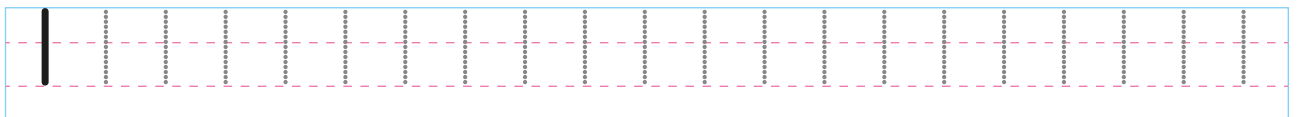
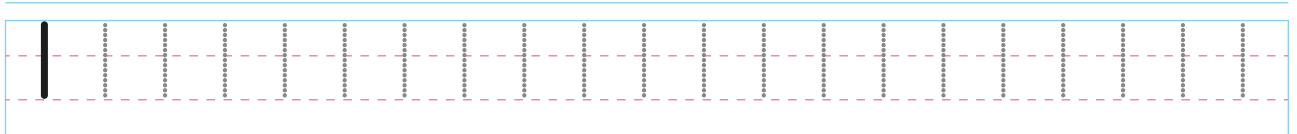
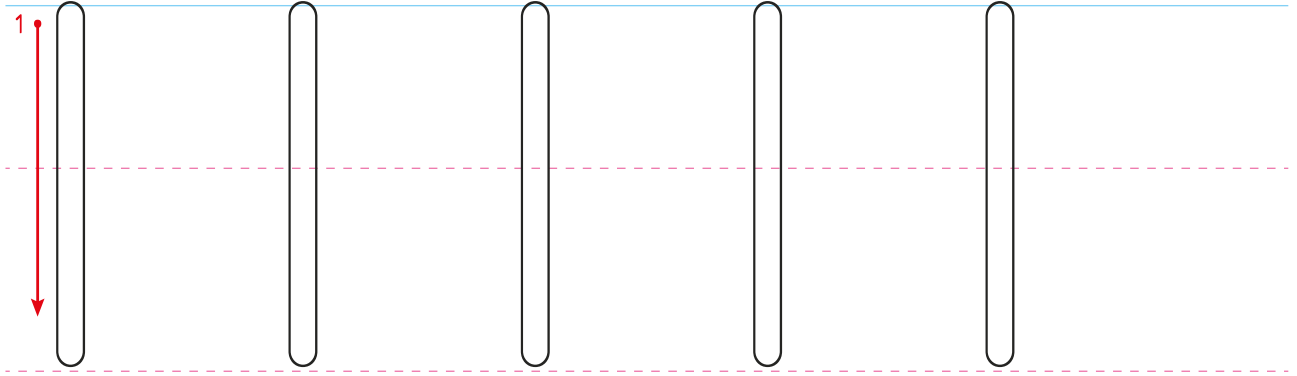



☞ "I" harfini yazalım.

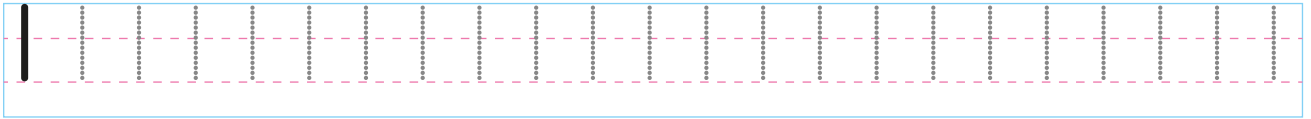
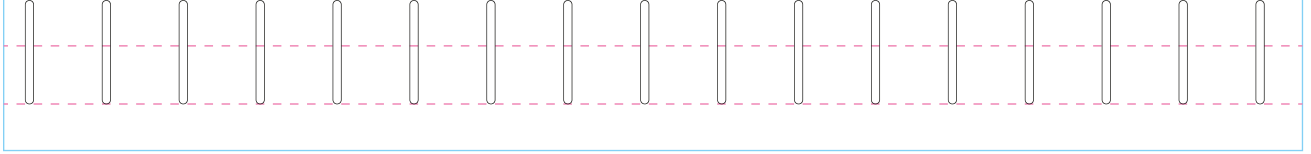



☞ Küçük "ı" harfinin yazılış yönüne dikkat edelim. İçinden kalemimizle geçelim.

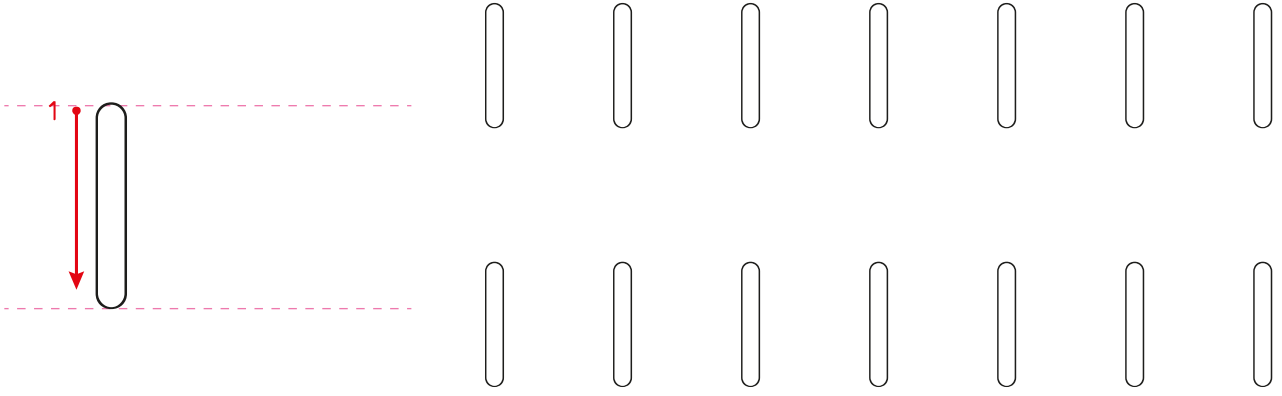

☞ "ı" harfinin yazılı olduğu yıldızları boyayalım.



👉 Yönergeleri uygulayalım.

• "ı" harfini boyayalım.



• "ı" harflerini bulup yuvarlak içine alalım.

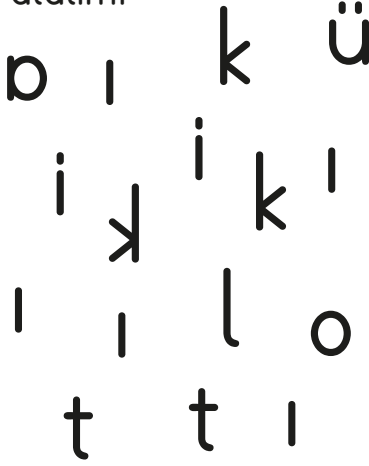

• Noktaları birleştiririm.

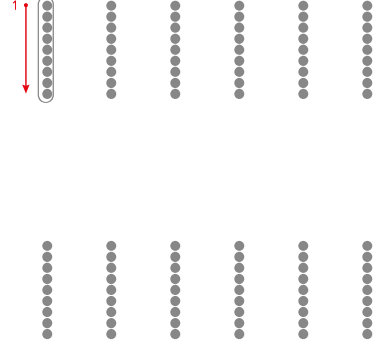

👉 Yazma yönlerine dikkat ederek "ı" harfini yazalım.

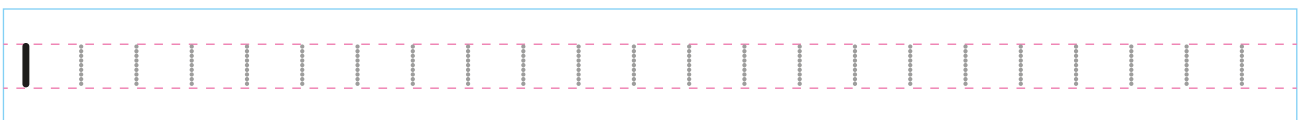
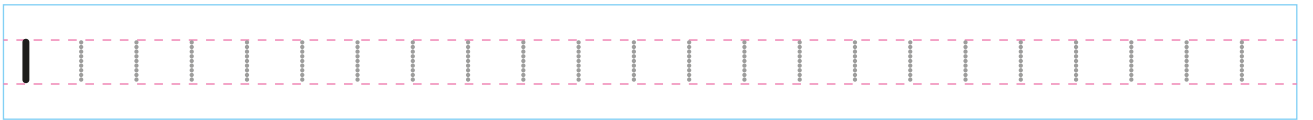
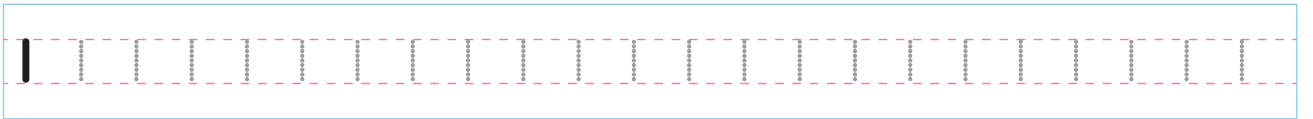
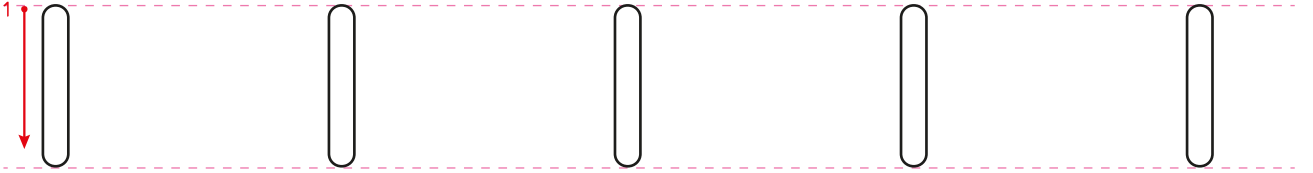



☞ "ı" harfini yazalım.

ı ı ı ı ı ı ı ı ı ı ı ı ı ı ı ı ı ı

ı ı ı ı ı ı ı ı ı ı ı ı ı ı ı ı ı ı

ı ı ı

ı

ı

ı

ı

ı

ı

ı

ı

ı





👉 Büyük "I" ve küçük "i" harfini yazalım.

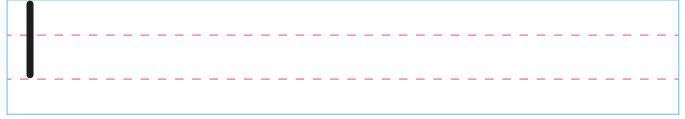
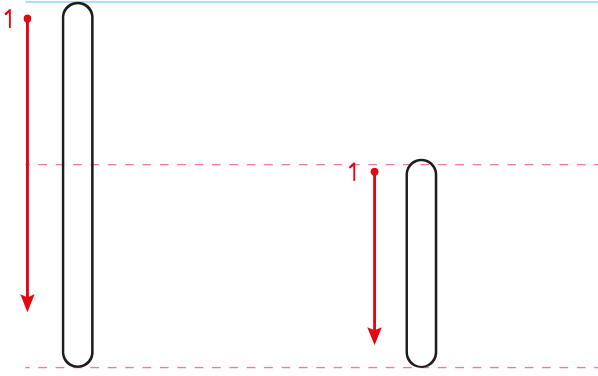



Okuyalım, yazalım.

ı l il il

l ı lı lı

il

lı

ı k ik ik

k ı kı kı

ik

kı

ya lı yalı

tat lı tatlı

at kı atkı

ta kı takı

kı na kına

Atkı ör.

Kına yak.

Tatlı yer.



Okuyalım, yazalım.

İ n in in

n İ nİ nİ

in

nİ

İ m im im

m İ mİ mİ

im

mİ

a nİ anİ

A nıl Anıl

ta nık tanık

tır mık tırmık

Anıl anı anlat.

Ona tanık ol.

Dört tırmık al.

Anıl tanık ol.



Okuyalım, yazalım.

ı t it it

t ı tı tı

it

tı

ı y iy iy

y ı yı yı

iy

yı

ar tı artı

tır nak tırnak

kı yı kıyı

yı lan yılan

yır tık yırtık

O, iki artı.

Yılanla oynama.

O etek yırtık.



Okuyalım, yazalım.

ı r ir ir r ı rı rı

Ir mak İrmak

a rı arı

ya rı yarı

ya rım yarım

Ta rık Tarık

İrmak yarım ekmek yer.

Tarık arı ile oynama.

İrmak ile Tarık tırmık alır.



☞ Kelimeleri okuyalım, yazalım.

yıl

kıl

tır

kır

takı

atkı

altı

artı

martı

tırmık

kıymık

Tarık

kayık

kıyma

altın

tarım

yılan

İrmak

mantık

tirtil



☞ Karışık hecelerden kelimeler oluşturup yazalım.

ran	ka	lık	▶	
ya	nık	u	▶	
lık	lak	ku	▶	
ki	lık	ra	▶	
yu	rı	ka	▶	
lı	a	kıl	▶	

☞ Görseli verilen varlıkların adını yazalım.



\_\_\_\_\_

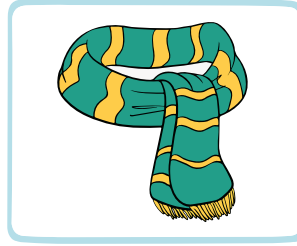

\_\_\_\_\_



\_\_\_\_\_



\_\_\_\_\_



\_\_\_\_\_



\_\_\_\_\_



☞ Karışık kelimelerden cümleler oluşturup yazalım.

Ayten'e

al

Akın

allık

Anıl

tartın

elmaları

alın

yaktı

İrmak

eline

kına

martılara

Tarık

atın

ekmek

takı

altın

Annem

takar

Akın

yeme

aman

tırnak





☞ Metni okuyalım. Aşağıya yazalım.

## IRMAK

Irmak kıymalı mantı alır.

Kıymalı mantı altı lira.

Irmak mantıyı ılık yer.

Kıymalı mantı tane tane,

Irmak alır altı tane.



Handwriting practice line with a dashed red line for the middle stroke.

Handwriting practice line with a dashed red line for the middle stroke.

Handwriting practice line with a dashed red line for the middle stroke.

Handwriting practice line with a dashed red line for the middle stroke.

Handwriting practice line with a dashed red line for the middle stroke.

Handwriting practice line with a dashed red line for the middle stroke.

👉 Cümleleri okuyalım. Soruları cevaplayalım.

⇒ İrmak kına yaktı. ⇒

1. Kim kına yaktı?

-----

2. İrmak ne yaktı?

-----

⇒ Anıl törene katılır. ⇒

1. Kim törene katılır?

-----

2. Anıl nereye katılır?

-----

⇒ İtir atkı takar. ⇒

1. İtir ne takar?

-----

2. Kim atkı takar?

-----



☞ Cümleleri okuyalım. Soruları cevaplayalım.

⇒ Akın Anıl'a altın alır. ⇒

1. Kim altın alır?

2. Akın ne alır?

⇒ Tarık kıymalı mantı yer. ⇒

1. Neli mantı yer?

2. Kim kıymalı mantı yer?

⇒ Irmak yerleri yıkar. ⇒

1. Irmak nereyi yıkar?

2. Kim yerleri yıkar?



👉 Metinleri okuyalım.

Al.

Tatlı al.

Altı tatlı al.

Altı kilo tatlı al.

Altı tatlı al.

Tatlı al.

Al.



Tak.

Atkı tak.

Anıl atkı tak.

Anıl iki atkı tak.

Anıl atkı tak.

Atkı tak.

Tak.

👉 Metinleri okuyalım.

Kur.

Takım kur.

Akın takım kur.

Akın altı takım kur.

Akın takım kur.

Takım kur.

Kur.



Yak.

Kına yak.

Irmak kına yak.

Irmak ona kına yak.

Irmak kına yak.

Kına yak.

Yak.



☞ Metinleri okuyalım.

Ye.

Mantı ye.

Itir mantı ye.

Itir kıymalı mantı ye.

Itir mantı ye.

Mantı ye.

Ye.



Oku.

Anı oku.

Anıl anı oku.

Anıl anılarını oku.

Anıl anı oku.

Anıl oku.

Oku.





👉 Metinleri okuyalım. Soruları cevaplayalım.

Minik tırtıl elma yer. Tatlı elma yer.  
Elmayı kıtır kıtır yer. Tatlı tırtıl, minik  
tırtıl. Ormana yürür tır tır.

1. Minik tırtıl ne yer?

2. Minik tırtıl nereye yürür?

Irmak İtir'a altın taktı. Yarım yarım  
altın taktı. Altın takı İtir'i mutlu etti.  
Takıyı kutuya attı.

1. Irmak kime altın taktı?

2. İtir'i ne mutlu etti?

Yönergeleri uygulayalım.

- Hayvan adlarını aşağıdan kesip yapıştıralım.

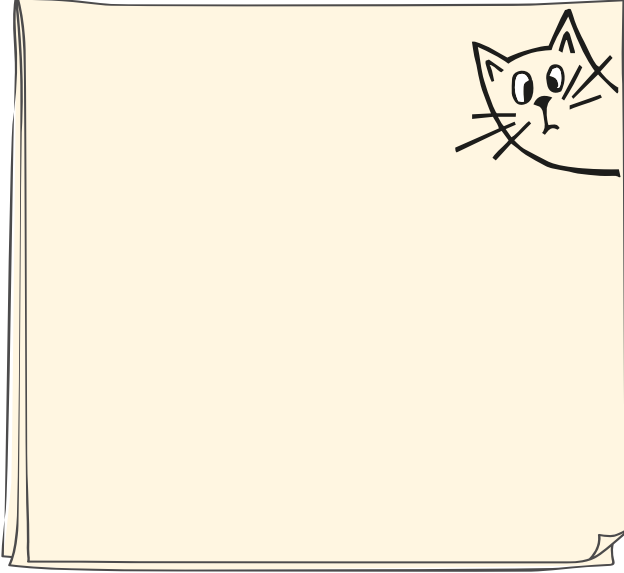

- Eşya adlarını aşağıdan kesip yapıştıralım.

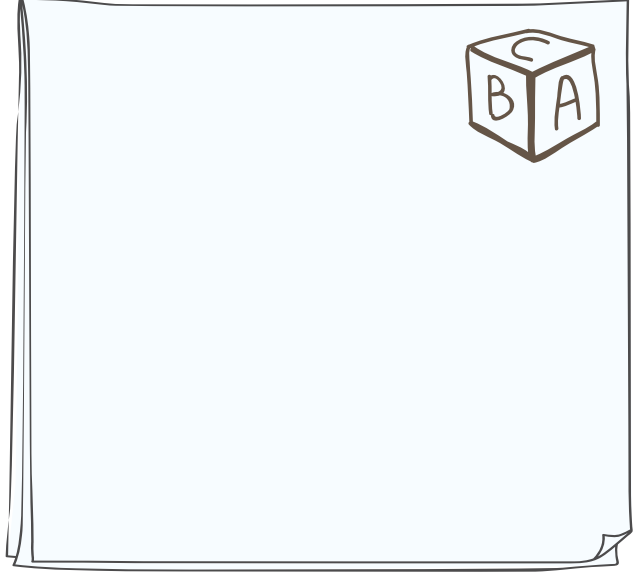

- Adında en çok "i" sesi olan görseli boyayalım.

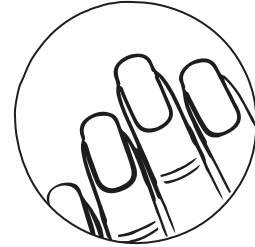
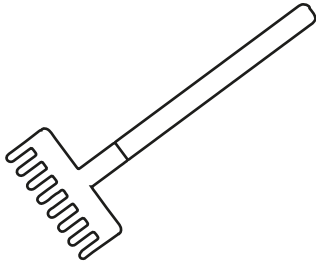

- Büyük "I" yazalım.

Blank writing area for the letter 'I' with a dashed line for the middle stroke.

Blank writing area for the letter 'I' with a dashed line for the middle stroke.

- Küçük "i" yazalım.

Blank writing area for the letter 'i' with a dashed line for the middle stroke.

Blank writing area for the letter 'i' with a dashed line for the middle stroke.

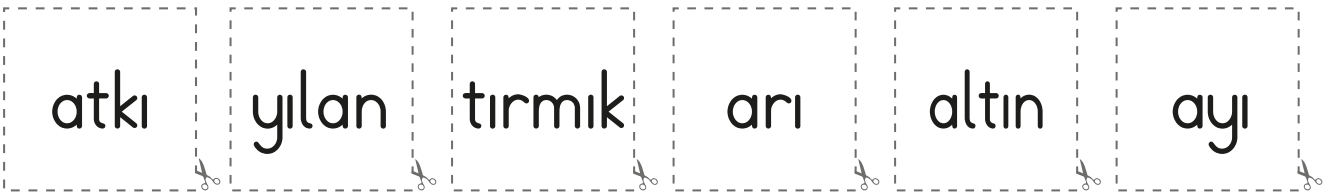



👉 Adında "d" sesi bulunan varlıkları boyayalım.

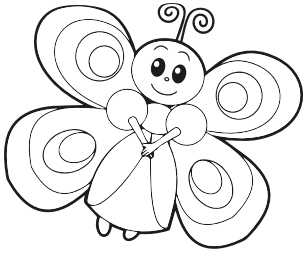
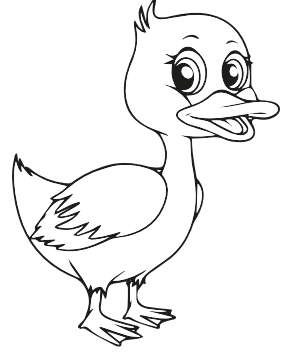
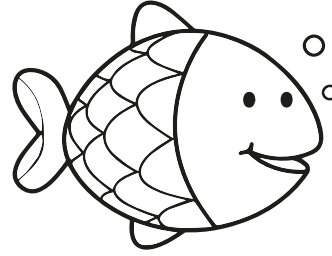
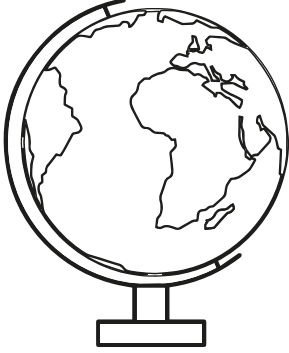

👉 "d" sesi ile başlayan varlıkları işaretleyelim.

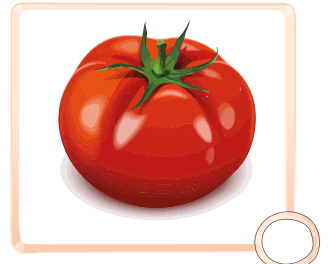
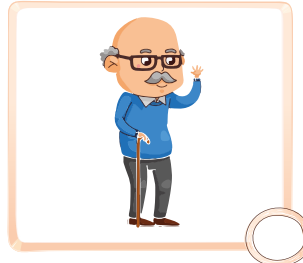
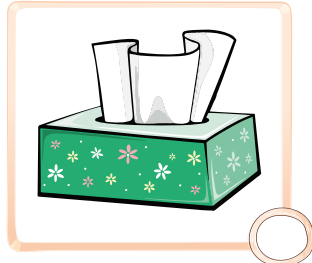
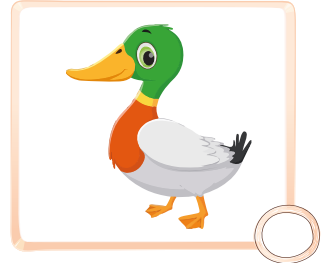
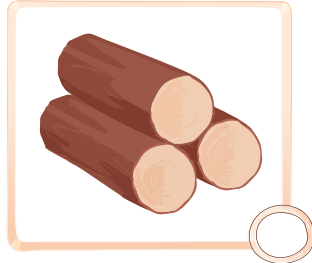

👉 Büyük "D" harfinin yazılış yönüne dikkat edelim. İçinden kalemimizle geçelim.

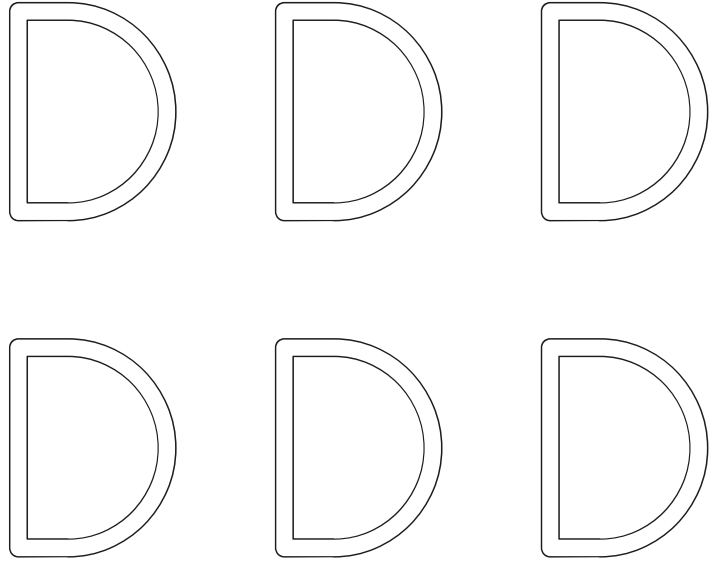
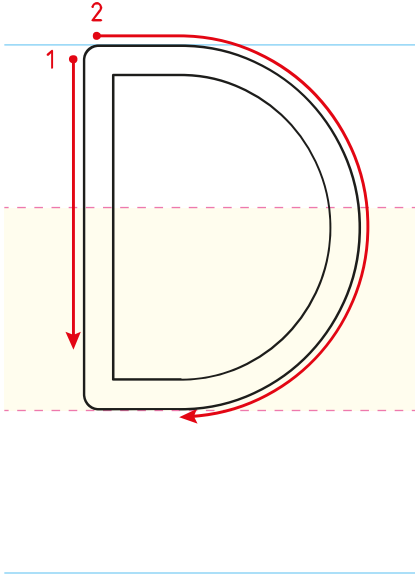

👉 "D" harfinin yazılı olduğu balonları boyayalım.

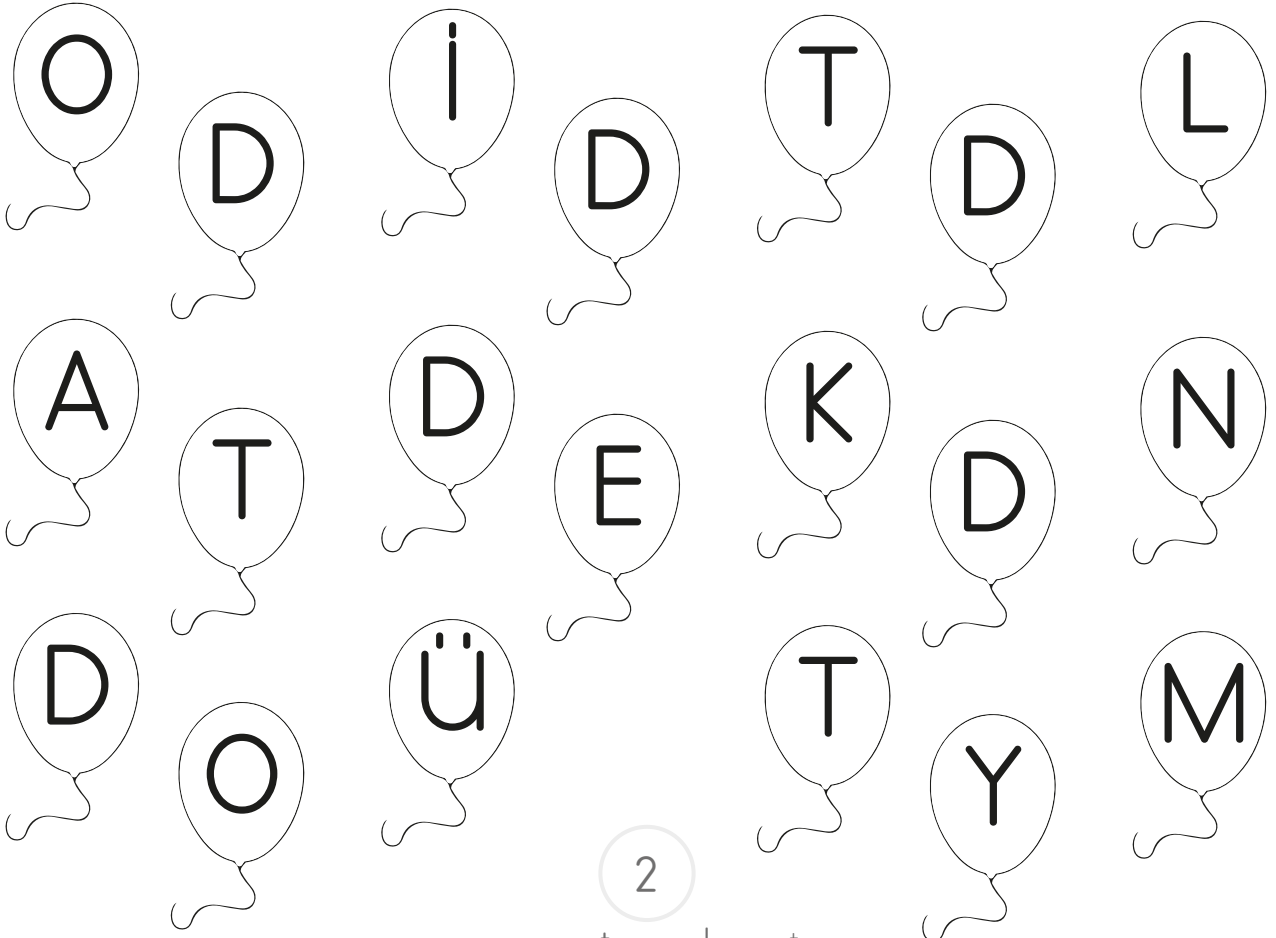

Yönergeleri uygulayalım.

• "D" harfini boyayalım.

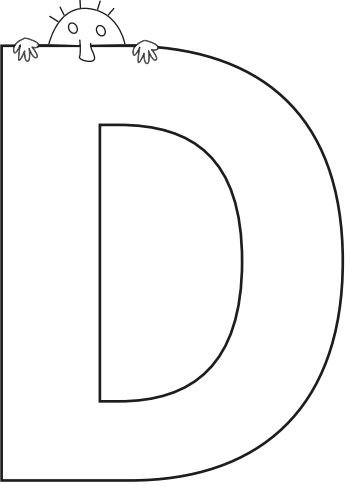

• "D" harflerini bulup yuvarlak içine alalım.



• Noktaları birleştirelim.

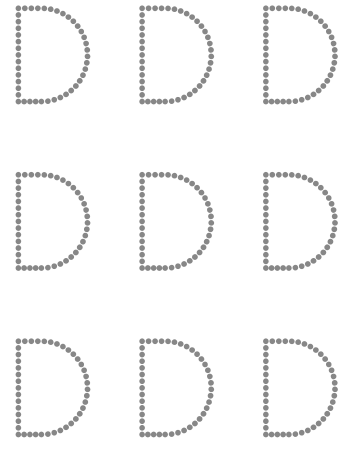

Yazma yönlerine dikkat ederek "D" harfini yazalım.

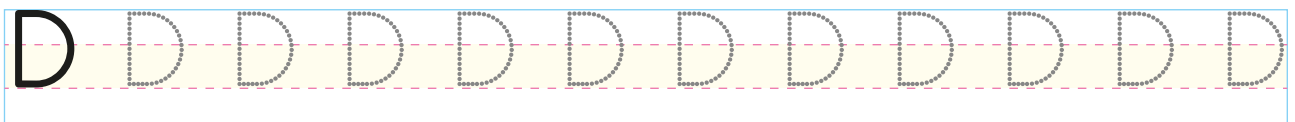
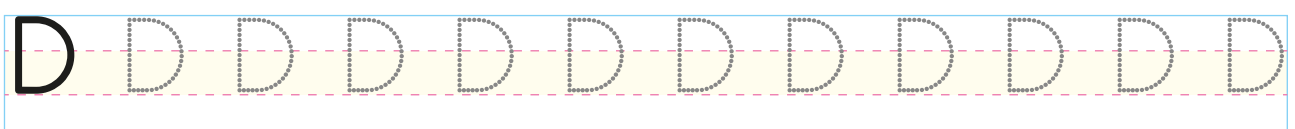
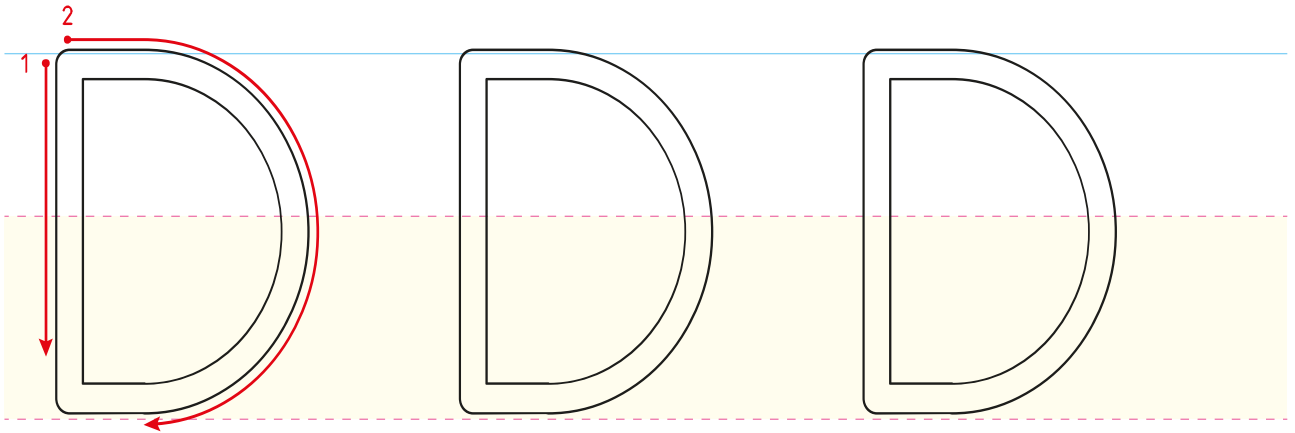



☞ "D" harfini yazalım.

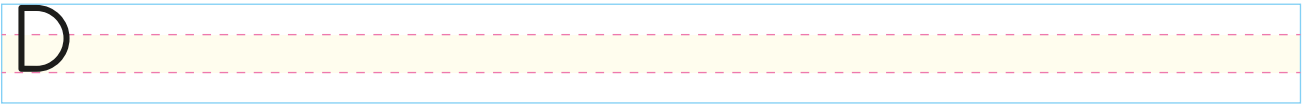
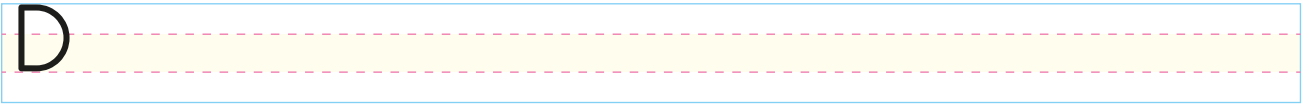
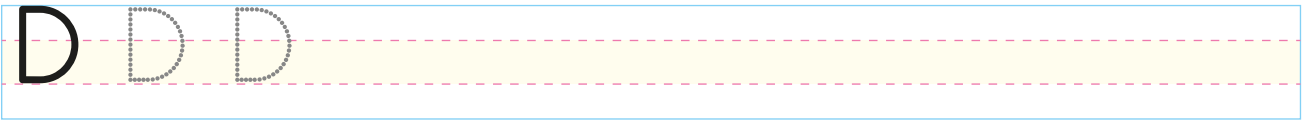
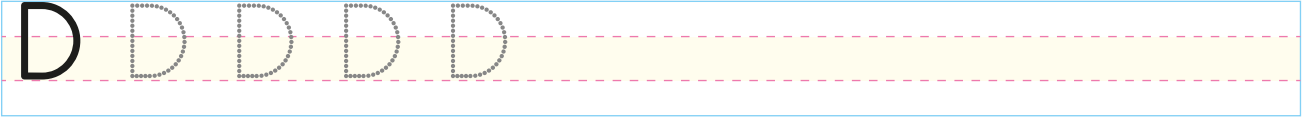
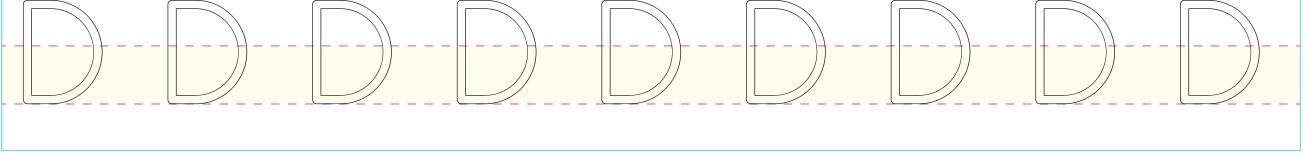



☞ Küçük "d" harfinin yazılış yönüne dikkat edelim. İçinden kalemimizle geçelim.

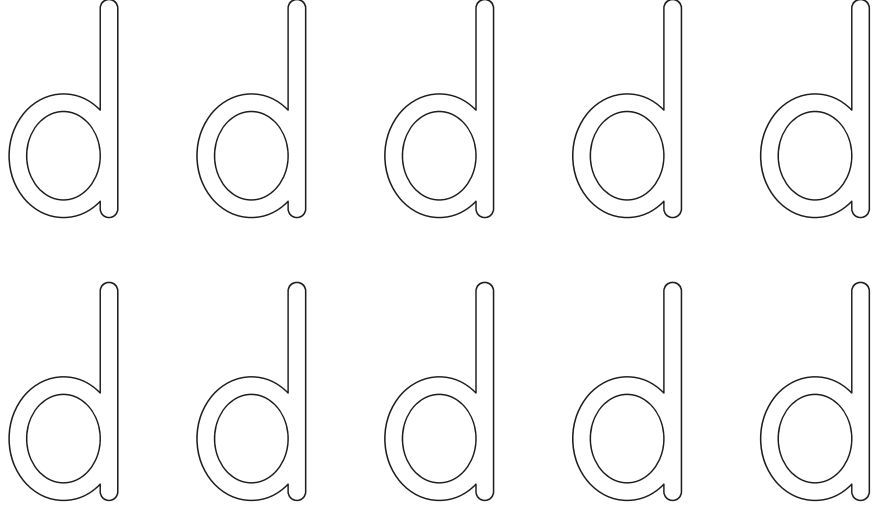
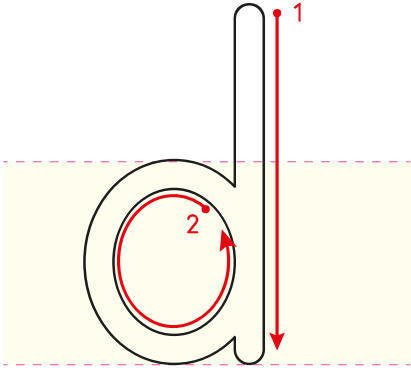

☞ "d" harfinin yazılı olduğu yıldızları boyayalım.



Yönergeleri uygulayalım.

• "d" harfini boyayalım.

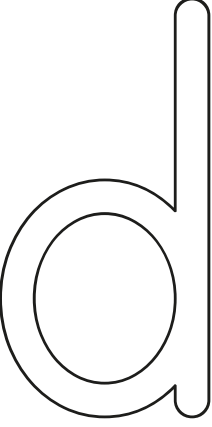

• "d" harflerini bulup yuvarlak içine alalım.

b d k ü  
d i k d  
y d l o  
t t d

• Noktaları birleştirelim.

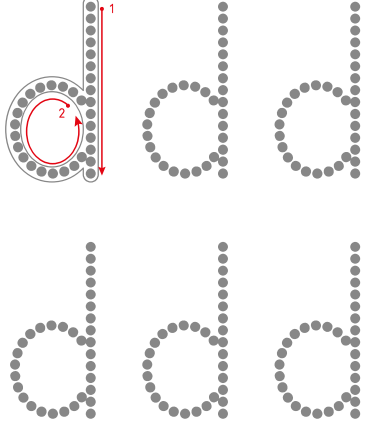

Yazma yönlerine dikkat ederek "d" harfini yazalım.

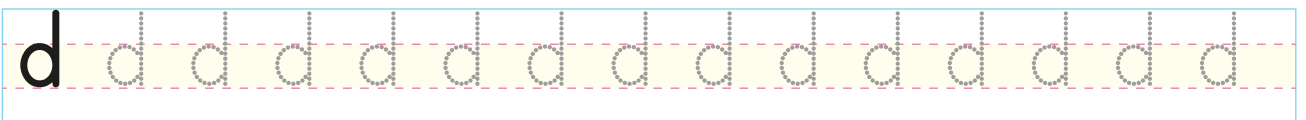
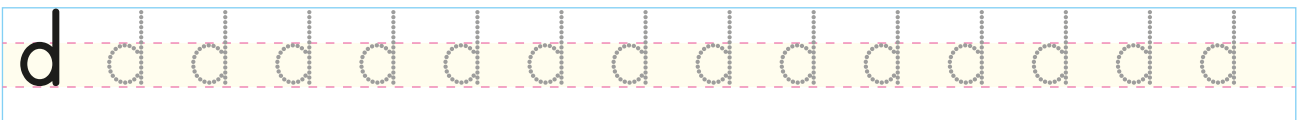
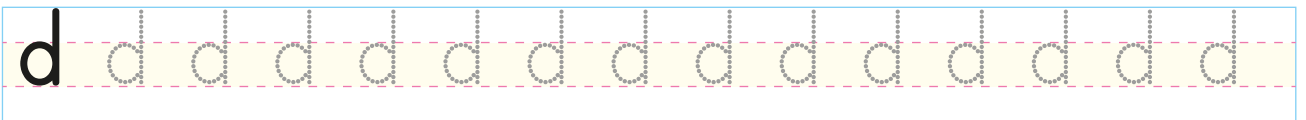
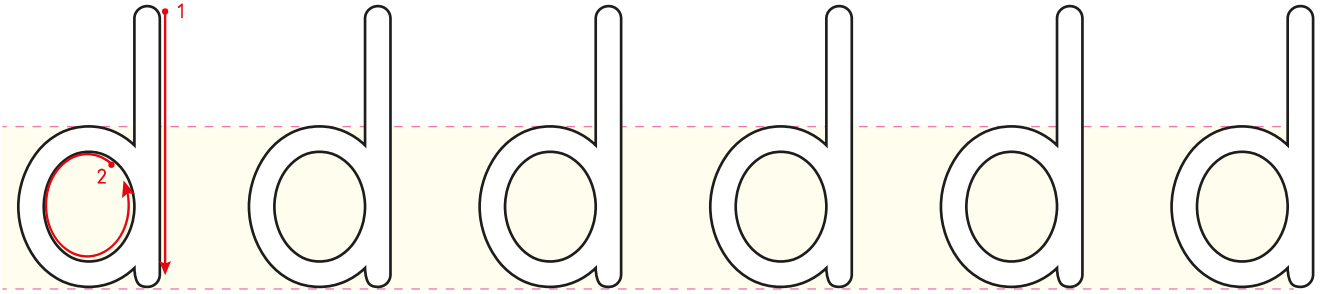



👉 "d" harfini yazalım.

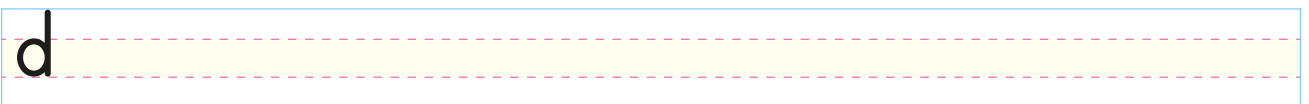
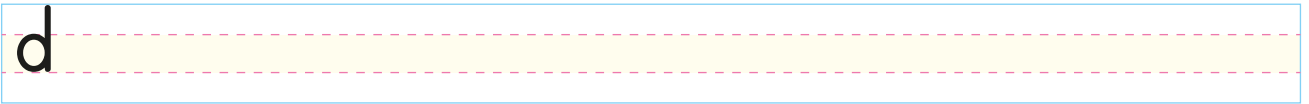
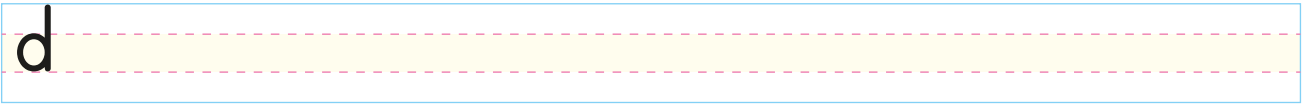
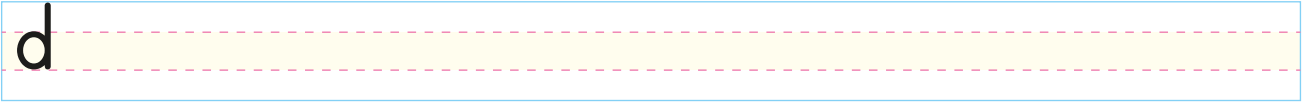
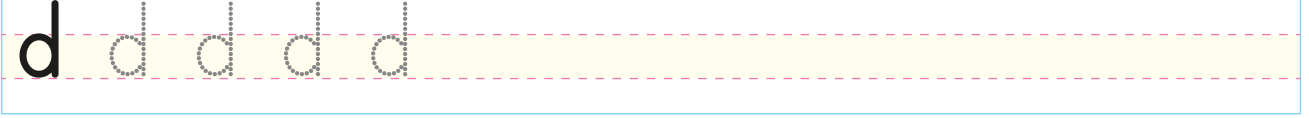
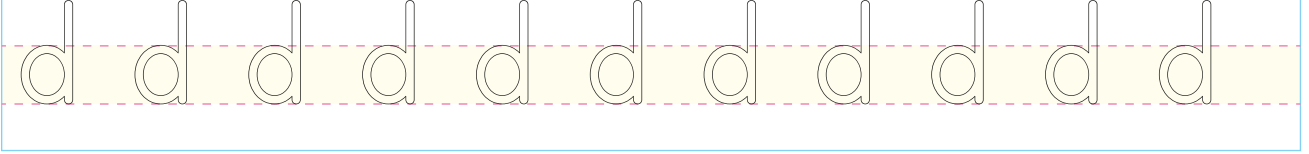



👉 Büyük "D" ve küçük "d" harfini yazalım.

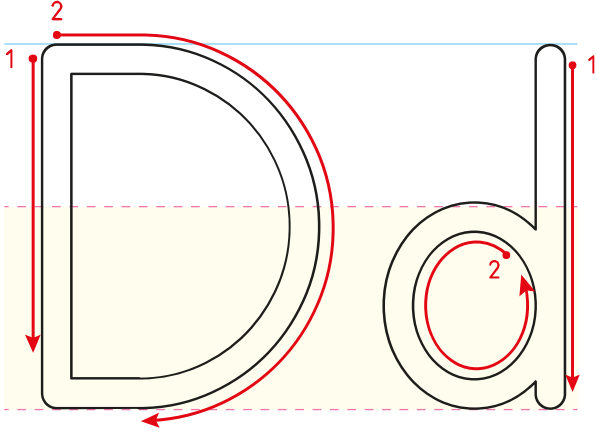

D D D D D D

D D D D

D

D

D D

d d d d d

d d d d

d

d

d

d





Okuyalım, yazalım.

e d ed d e de

a d ad d a da

i d id d i di

o d od d o do

de di dedi E da Eda

Eda al dedi.

De met Demet dok tor doktor

Demet doktor ol.

do lu dolu De rin Derin

Derin o dolu.

da dı dadı o da oda

Eda dadı odada.



Okuyalım, yazalım.

u d ud d u du

ü d üd d ü dü

ö d öd d ö dö

ı d id d ı di

Du ru Duru du rak durak

Duru durakta in.

Dün ya Dünya dö ner döner

Dünya dönüyor.

Or du Ordu kal dı kaldı

Ordu'da kaldı.

Ay dın Aydın ö dül ödül

Aydın ödül aldı.



☞ Heceleri eşleştirip kelimeler oluşturalım.

de	dak	▶	
dok	ney	▶	
du	yo	▶	
ke	tor	▶	
rad	di	▶	

☞ Karışık hecelerden kelimeler oluşturup yazalım.

len	de	kar	▶	
ya	dün	da	▶	
dun	o	luk	▶	
di	lat	ta	▶	
ad	ye	li	▶	
ma	don	dur	▶	
dal	ya	ma	▶	

☞ Cümleleri görsellerin adlarıyla tamamlayalım. Cümleleri okuyalım.



Arda ..... aldı.



Duru ..... yedi.



..... araya daldı.



Demet ..... erik yedi.

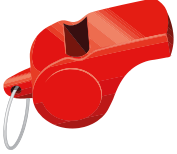

Eda Dilâya ..... aldı.



Minik ..... eti yedi.



..... daima döner.



..... tane dürüm aldı.



👉 Aynı şeklin içindeki kelimelerle cümle oluşturalım. Cümleleri yazalım.

indi

dondurma

yedi

Dedem

dört

dutlu

ekmek

dört

dinliyor

dereye

Erdem

Arda

yedi

Damla

ördek

dolma

radyo

dilimle

Blank writing line with a dashed midline for sentence construction.

Blank writing line with a dashed midline for sentence construction.

Blank writing line with a dashed midline for sentence construction.

Blank writing line with a dashed midline for sentence construction.

Blank writing line with a dashed midline for sentence construction.



👉 Cümleleri okuyalım. Soruları cevaplayalım.

⇒ Demet ödül aldı. ⇒

1. Kim ödül aldı?

2. Demet ne aldı?

⇒ Dedem dana aldı. ⇒

1. Kim dana aldı?

2. Dedem ne aldı?

⇒ Leylek dala kondu. ⇒

1. Ne dala kondu?

2. Leylek neye kondu?



👉 Cümleleri okuyalım. Soruları cevaplayalım.

⇒ Duru doktor oldu. ⇒

1. Kim doktor oldu?

2. Duru ne oldu?

⇒ Kadir mindere oturdu. ⇒

1. Kim mindere oturdu?

2. Kadir nereye oturdu?

⇒ Eda düdük öttürdü. ⇒

1. Kim düdük öttürdü?

2. Eda ne öttürdü?

👉 Metinleri okuyalım.

Derya

Derya aldı.

Derya ödül aldı.

Derya dört ödül aldı.

Derya ödül aldı

Derya aldı.

Derya



Duru

Duru oldu.

Duru doktor oldu.

Duru dün doktor oldu.

Duru doktor oldu.

Duru oldu.

Duru





Metinleri okuyalım.

Damla

Damla yedi.

Damla dut yedi.

Damla yedi dut yedi.

Damla dut yedi.

Damla yedi.

Damla

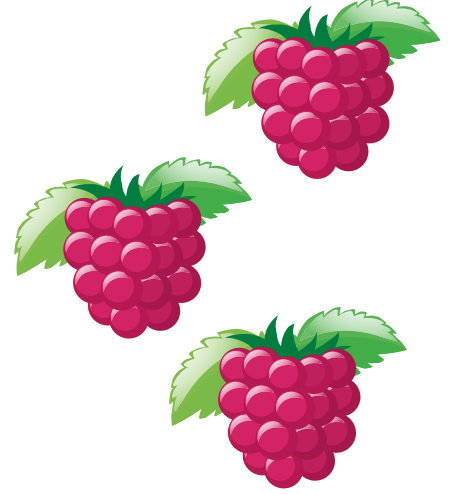

Dilek

Dilek kırdı.

Dilek dalı kırdı

Dilek demin dalı kırdı.

Dilek dalı kırdı.

Dilek kırdı.

Dilek



Metinleri okuyalım.

Ada

Ada aldı.

Ada düdüğü aldı.

Ada Dilay'a düdüğü aldı.

Ada düdüğü aldı.

Ada aldı.

Ada

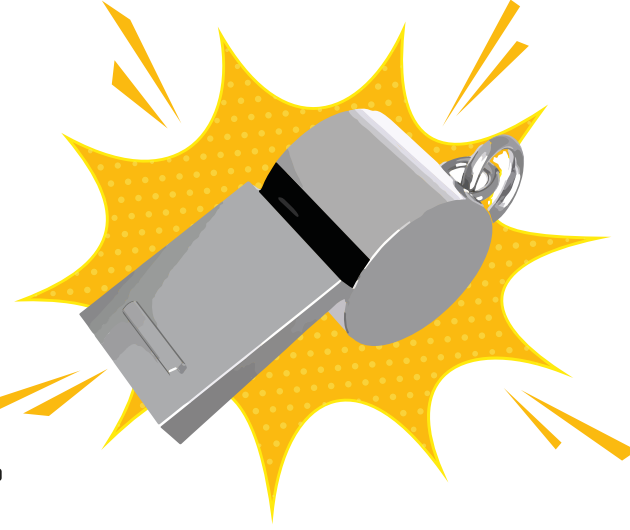

Arda

Arda aradı.

Arda dayısını aradı.

Arda dün dayısını aradı.

Arda dayısını aradı.

Arda aradı.

Arda



☞ Metni okuyalım. Aşağıya yazalım.

# DÜNYA

Dünya durmadan döner.

Eda dikkatli dinle.

Kadir, Dünya'yı anlatıyor.

Kadir'i daima dinle.

Dünya'yı ondan dinle.



Handwriting practice line with a dashed midline.

Handwriting practice line with a dashed midline.

Handwriting practice line with a dashed midline.

Handwriting practice line with a dashed midline.

Handwriting practice line with a dashed midline.

Handwriting practice line with a dashed midline.

Handwriting practice line with a dashed midline.

👉 Metni okuyalım. Soruları cevaplayalım.

## DEDEM

Dedemin adı Kadir. Dedem adada oturur. Dedem emekli oldu. Adadan daire aldı. Annemi aradı. Annemin adı Eda. Annem mutlu oldu. Dedeme radyo aldı.

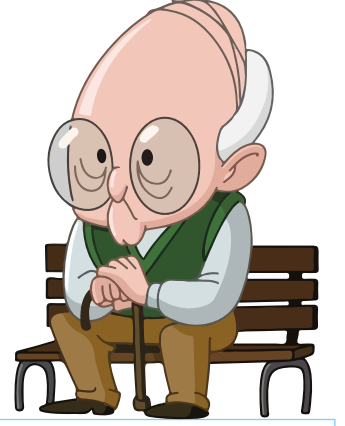

1. Dedenin adı nedir?

2. Kadir Dede ne aldı?

3. Daireyi nereden aldı?

4. Kadir Dede kimi aradı?

Metni okuyalım. Soruları cevaplayalım.

## DONDURMA

Derin dükkana oturdu. "İki adet dondurma" dedi. Ada yanında durdu. Derin dondurma yedi. Doktor Derin'e dedi ki: "Artık dondurma yeme." Derin artık dondurma yemiyor.



1. Derin nereye oturdu?

2. Derin'in yanında kim durdu?

3. Doktor Derin'e ne dedi?

☞ Metinleri okuyalım. İstedığımız sonu işaretleyelim.

Duman bir kedi.  
Demet onu yoldan aldı.  
Duman'a mama aldı.  
Duman'ın karnı doydu.

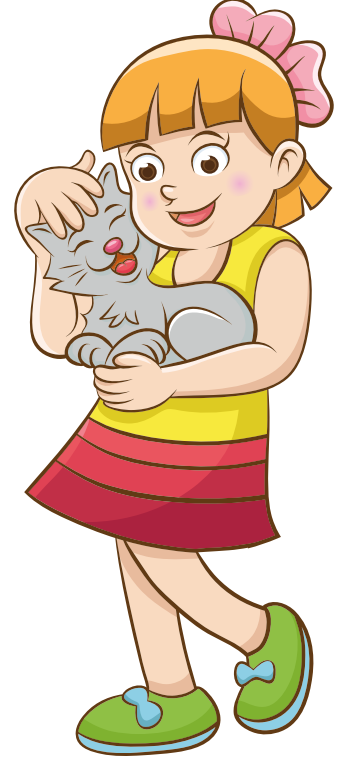

- Duman oyun oynadı.  
 Duman mutlu oldu.

Dilek Ordu'da oturuyor.  
Ordu'da köyde oturuyor.  
Köy derenin kenarında.  
Dilek orada dinlenir.



- Ördeklere yem atar.  
 Dereye olta atar.

☞ Metni okuyalım. İstedığımız sonu işaretleyelim.

Damla meydana indi.  
Yanında bir kedi durdu.  
Damla kediyi kollarına  
aldı. Adını Dünya koydu.

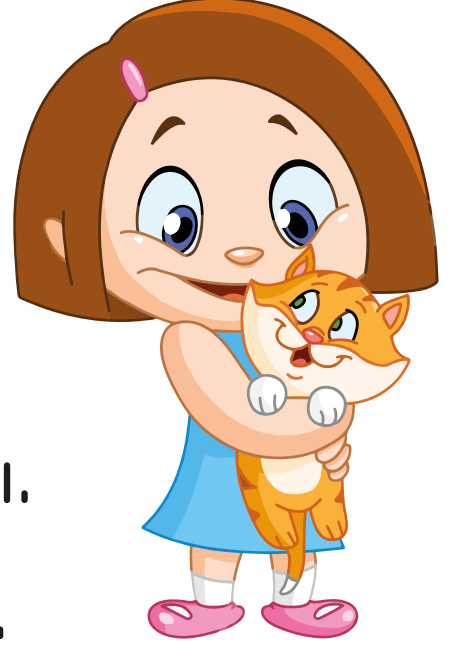

- Dünya ile oyun oynadı.  
 Dünya'yı yolda unuttu.

☞ Görseli verilen varlıkların adını yazalım.

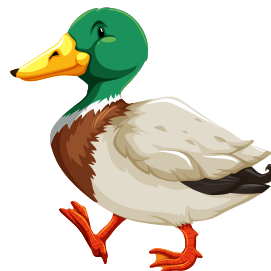



Yönergeleri uygulayalım.

• Kız isimlerini yapıştıralım.

• Erkek isimlerini yapıştıralım.



• "d" ile başlayan altı kelime yazalım.

1-

2-

3-

4-

5-

6-

• Adında en az "d" sesi olan görseli boyayalım.

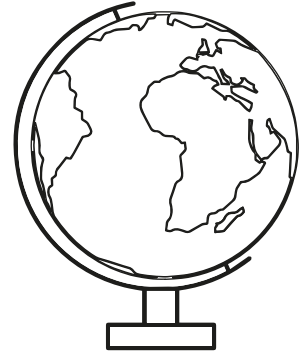
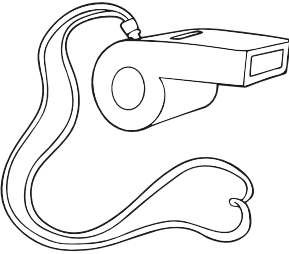

Derya

Arda

Adem

Dilek

Damla

Adnan



# MATEMATİK

1

2

3

4

5

6

7

8

+

-

9

0

÷

×

=

?





☞ Görselleri solda sağa doğru sıra bildiren sayılarla sıralayalım.  
Yönergeleri uygulayalım.

- 3. sıradaki balonu boya.

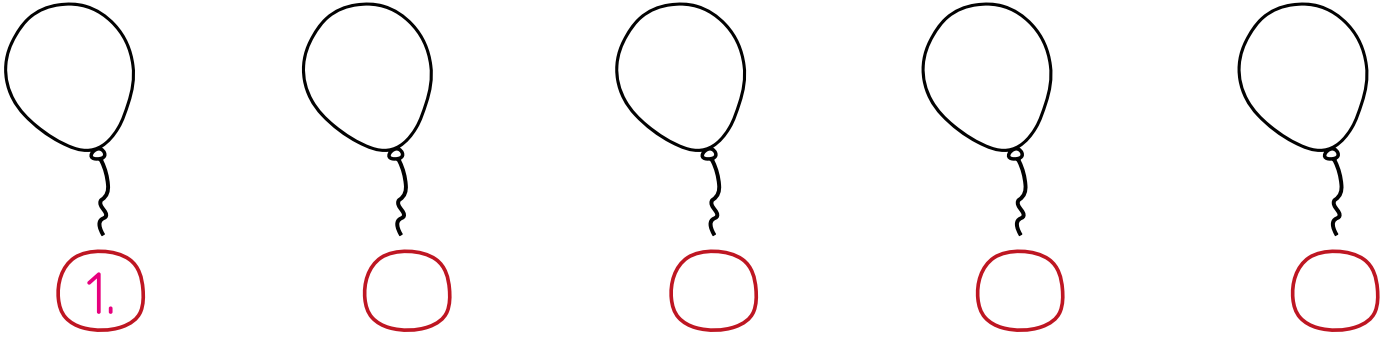

- 7. sıradaki kalemi boya.

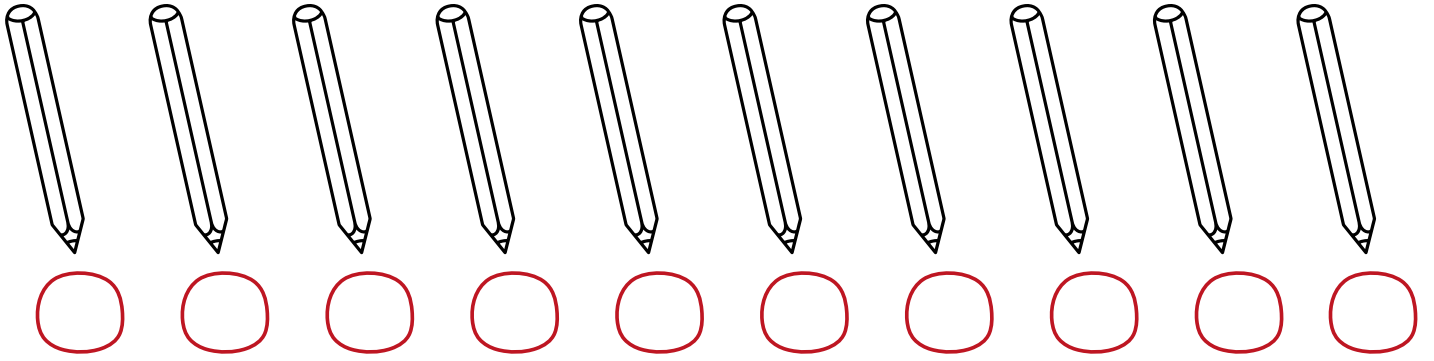

- 2. sıradaki elmayı boya.

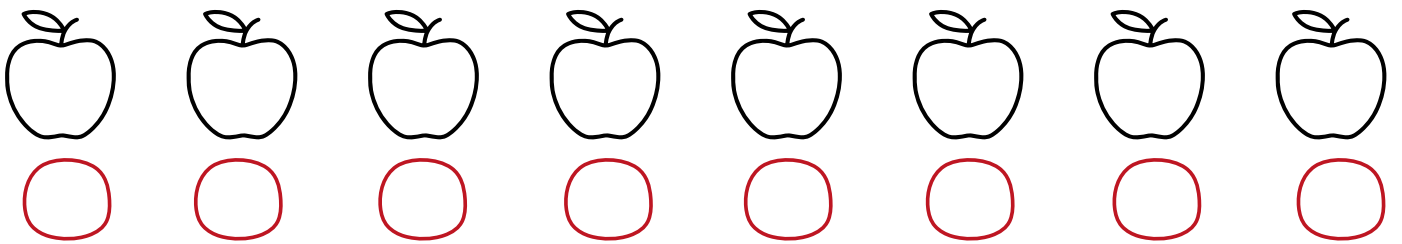

- 5. sıradaki yıldızı boya.

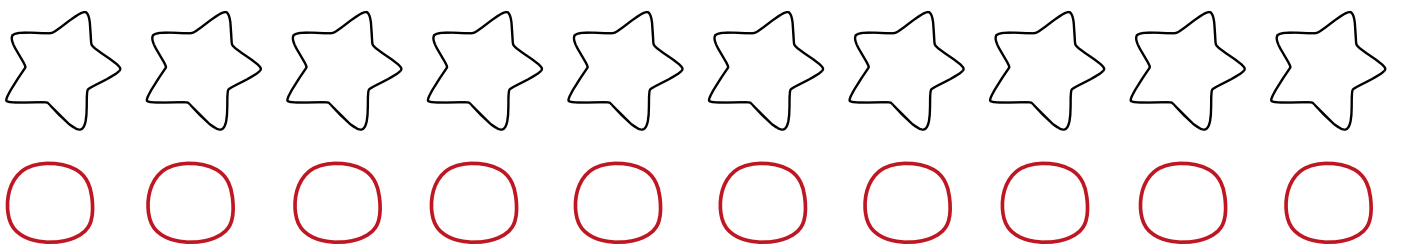

☞ Belirtilen sıradaki varlıkları örnekteki gibi yuvarlak içine alalım.

4.



7.



1.



3.



5.

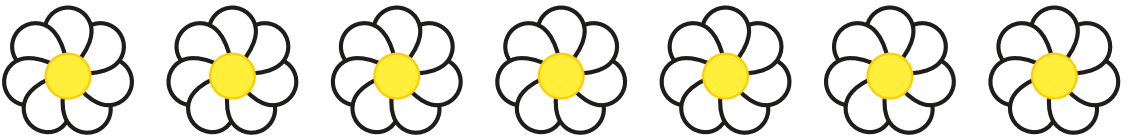

2.





☞ Sıradaki çocukların adını sıra sayılarının yanına yazalım.

Mine Onur Öykü Nil Ömer Mete



1.

2.

3.

4.

5.

6.



Oya Kaan Ela Ata Rana Erim



1.

2.

3.

4.

5.

6.



İlk iki kutudaki varlıkları bir araya getirip boş kutuya çizelim.

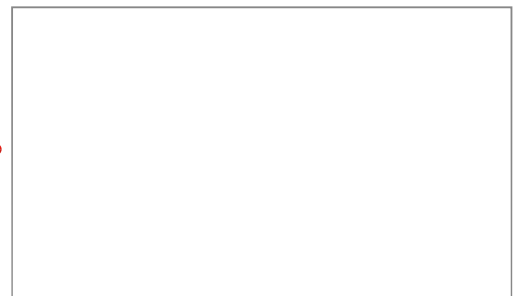
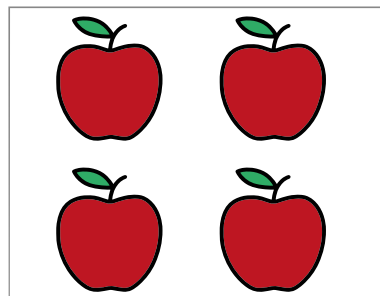
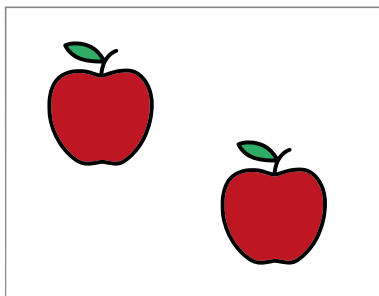
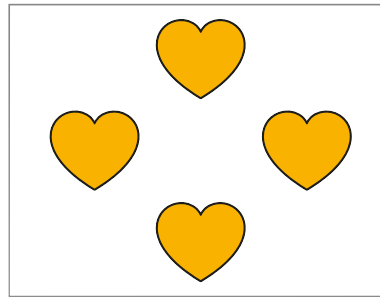
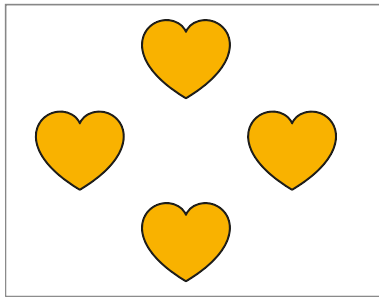
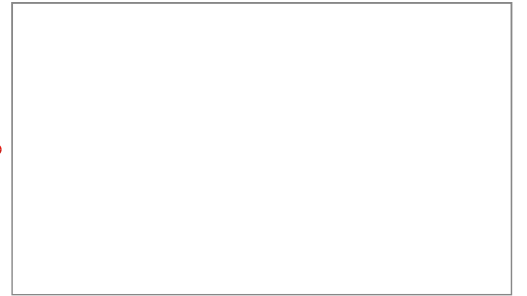
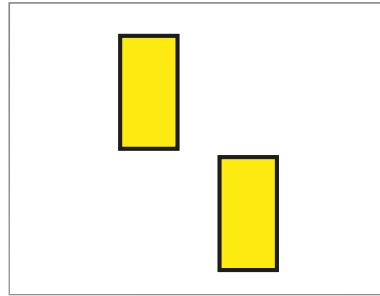
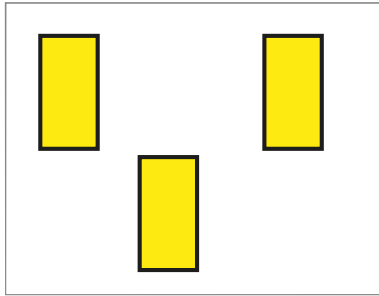
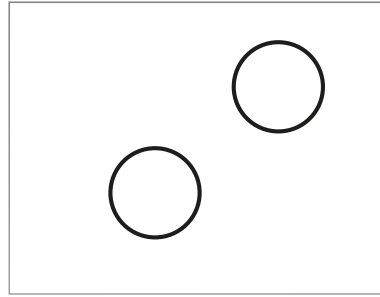
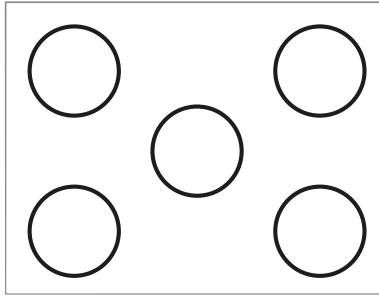
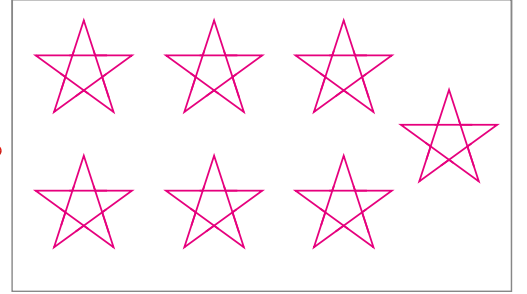
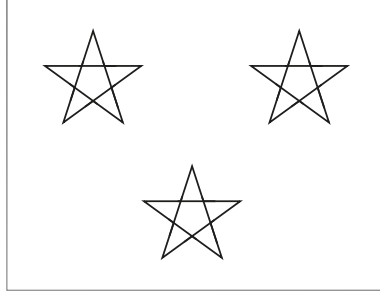
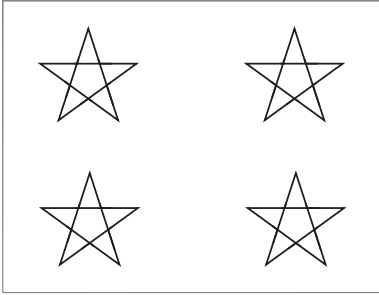



☞ Modellenen işlemleri örnekteki gibi yapalım.

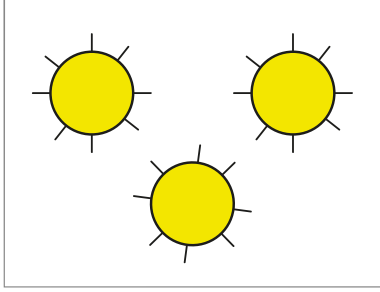

3

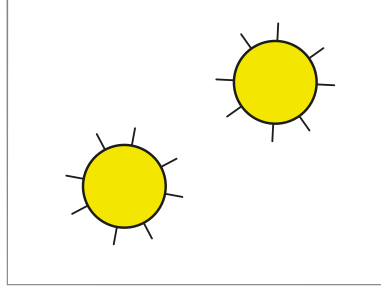

2

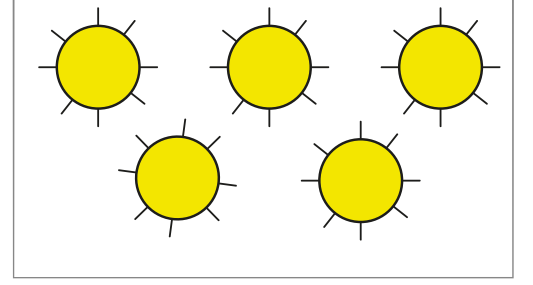

5

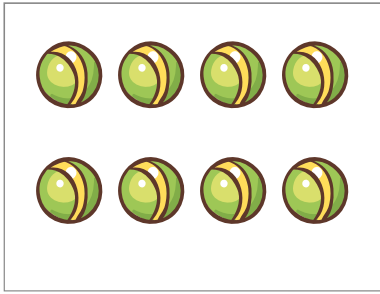
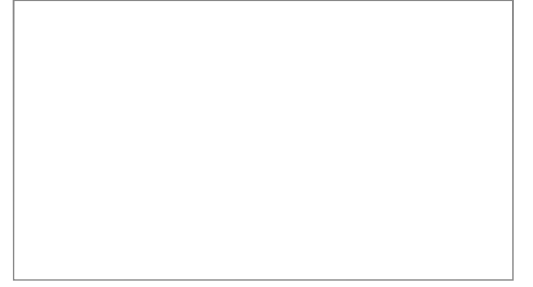
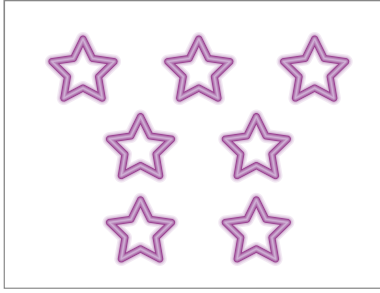
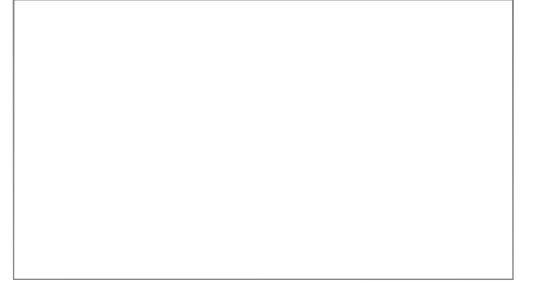
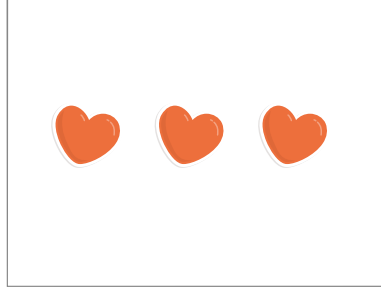
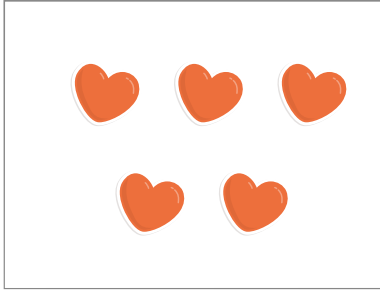



artı



eşittir

☞ Modellenen toplama işlemlerini yapalım.

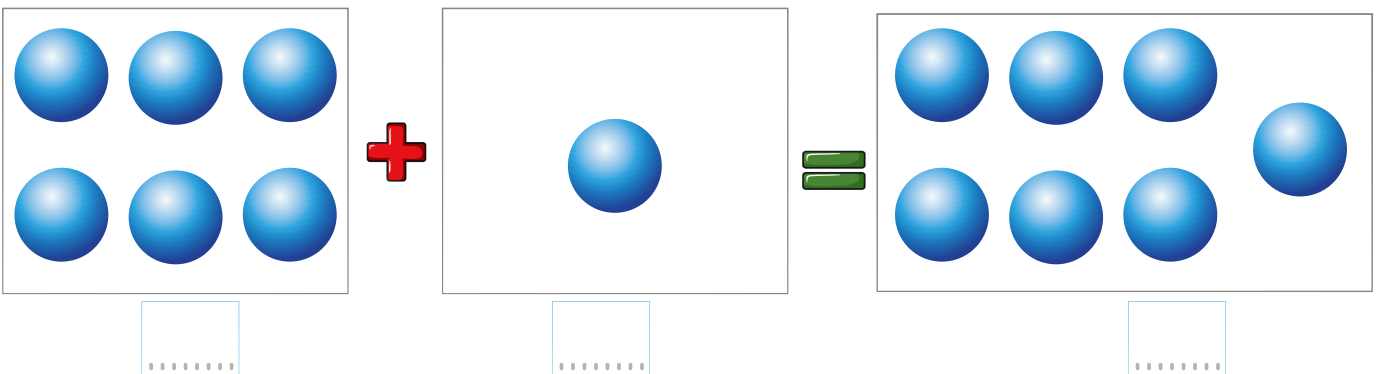
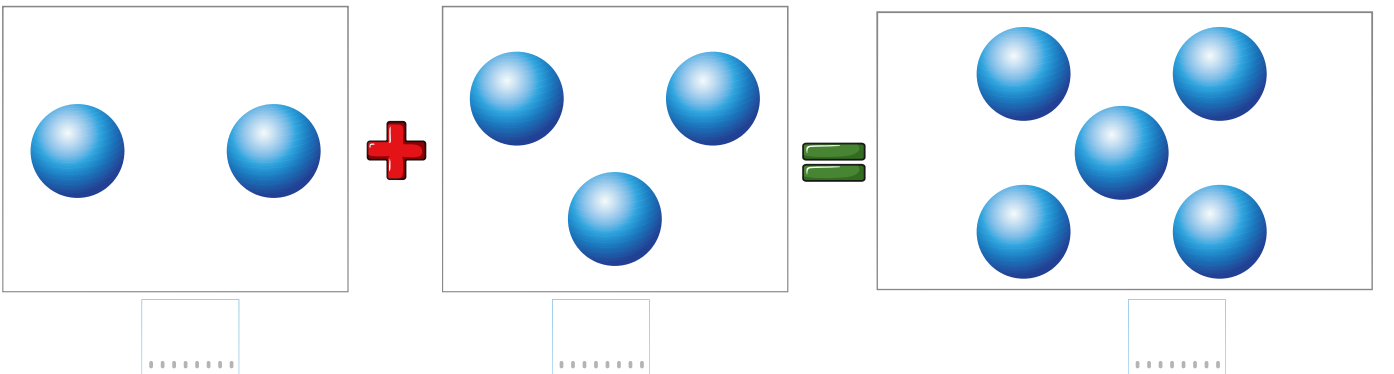
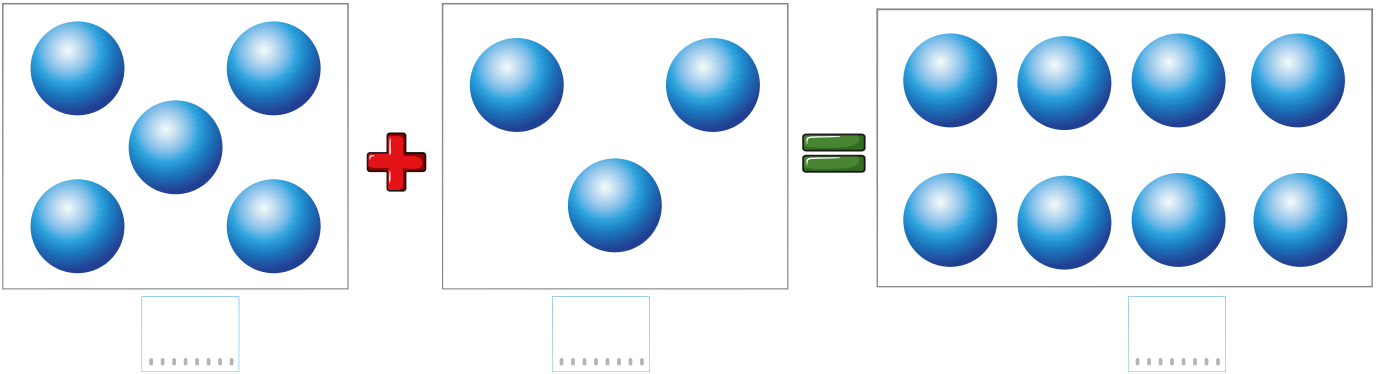
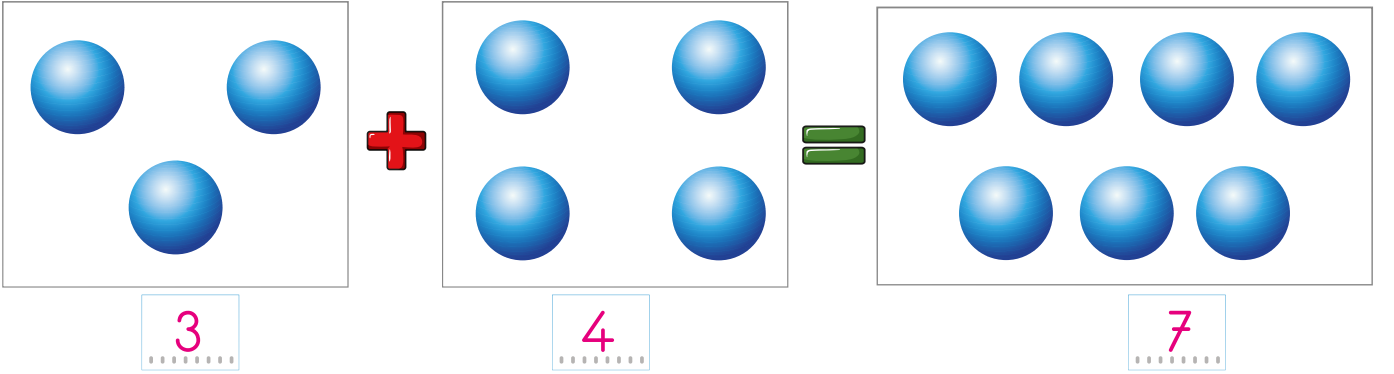



☞ Modellenen toplama işlemlerini örnekteki gibi yapalım.

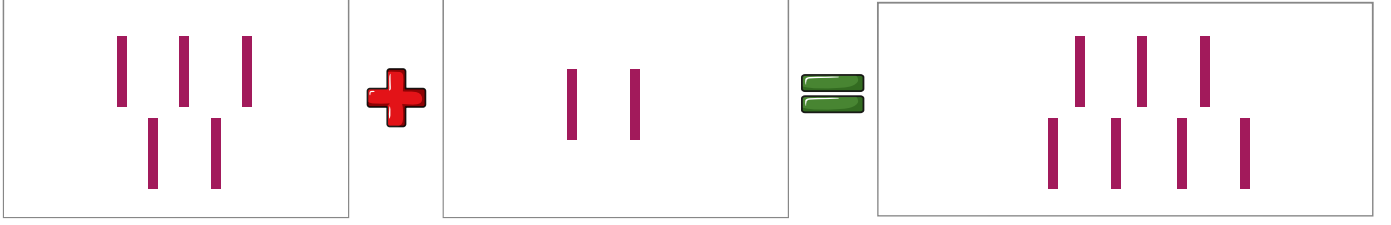

5

+

2

=

7

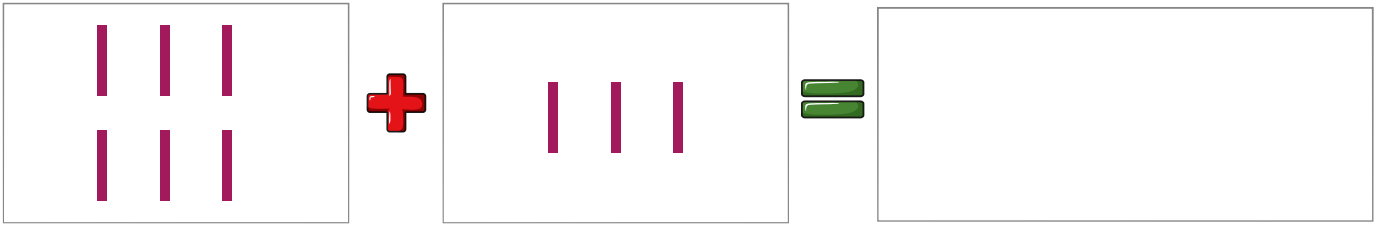

+

=

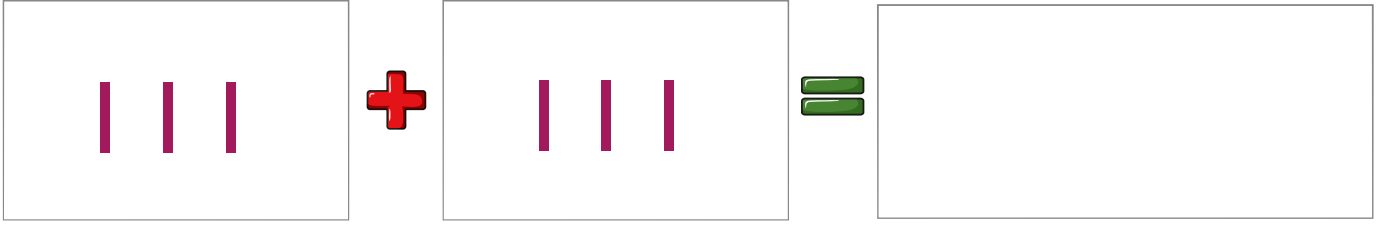

+

=

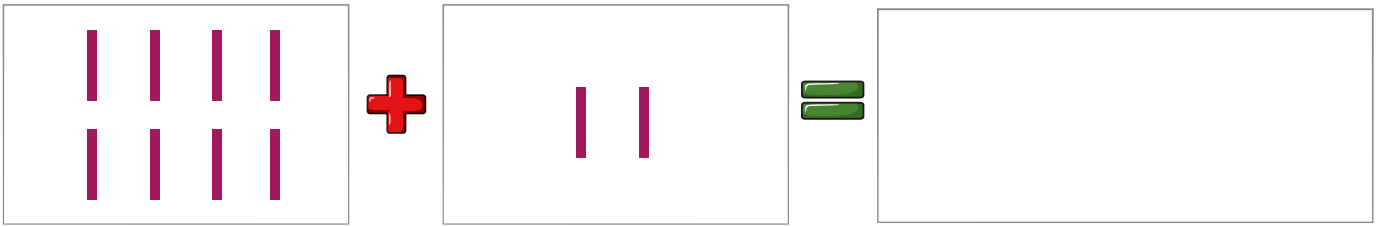

+

=

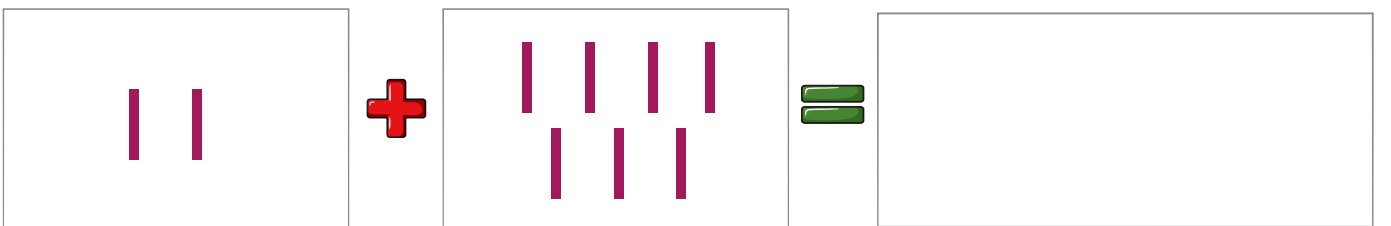

+

=





3 + 4 =



2 + 6 =



4 + 5 =



8 + 4 =



7 + 3 =



☞ Aşağıda modellenen işlemleri sözlü olarak ifade edelim.

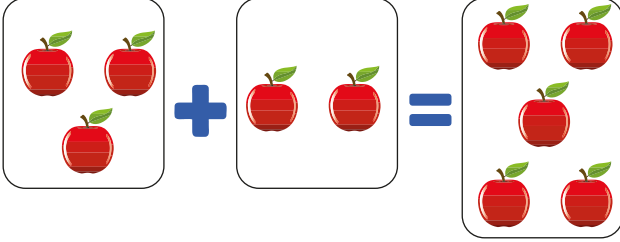

3 elma, 2 elma daha  
5 elma eder.

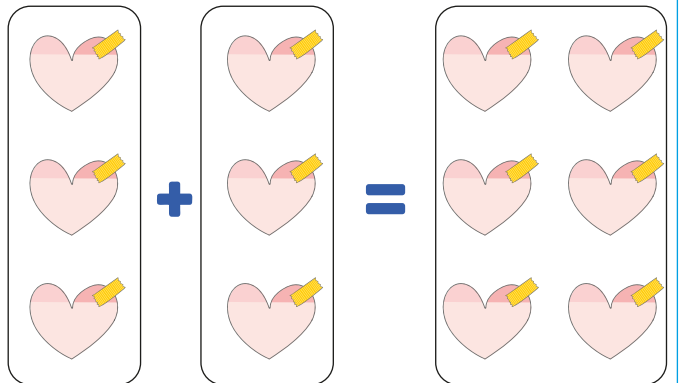
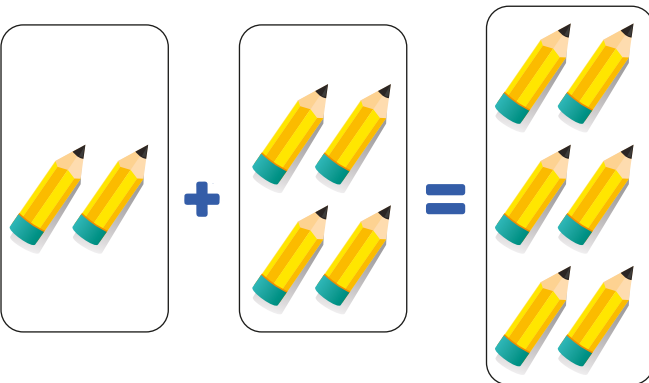
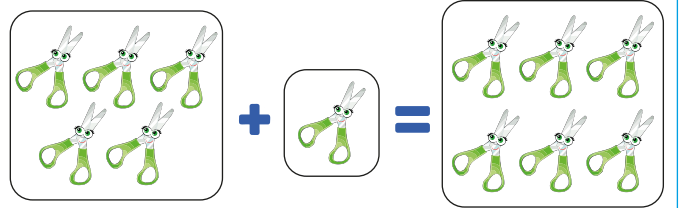
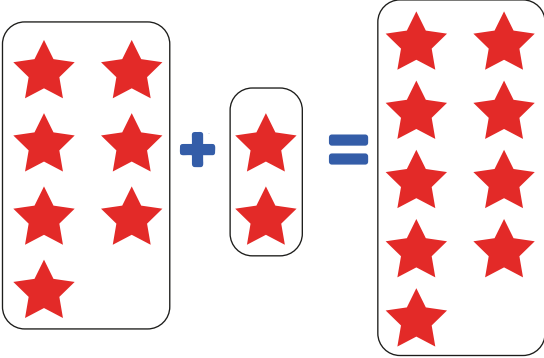
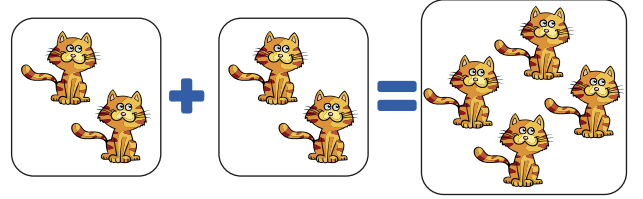
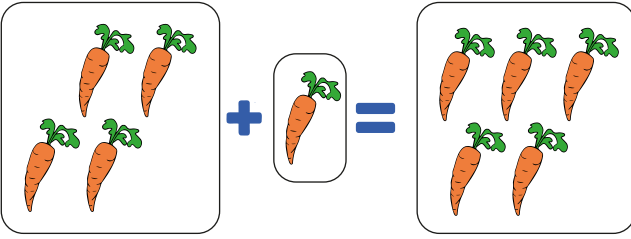

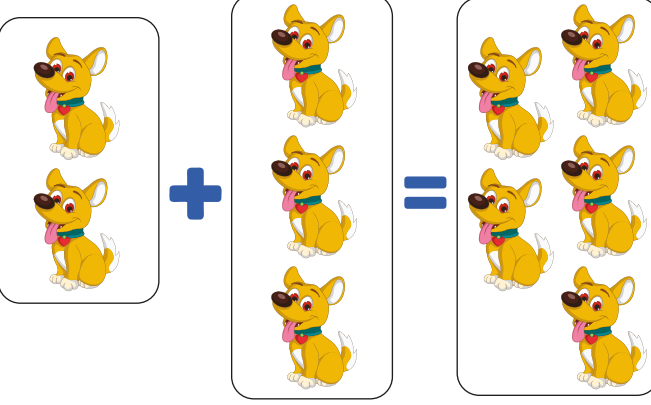
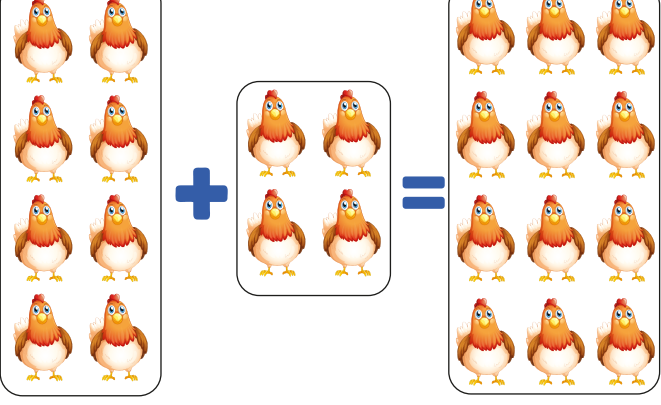
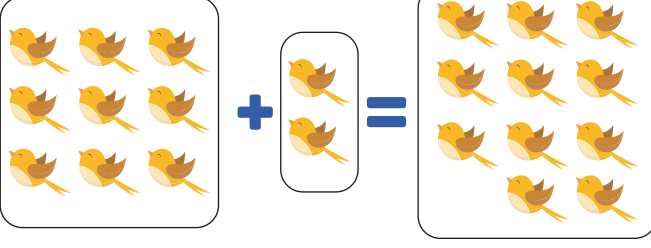
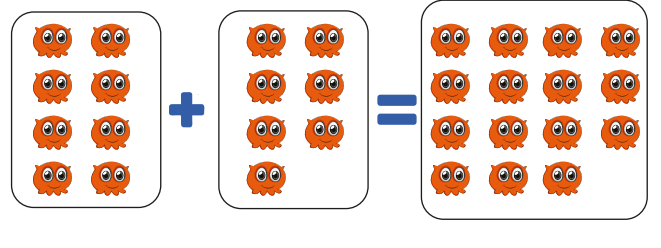
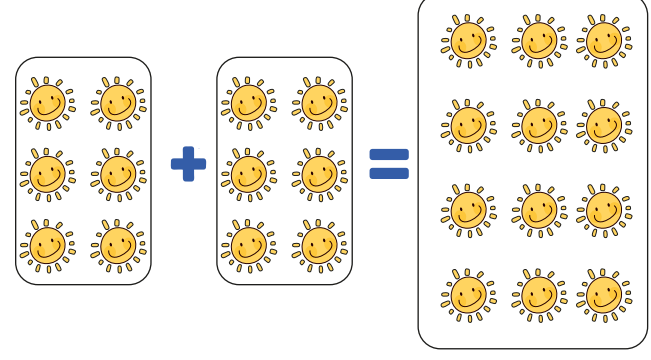
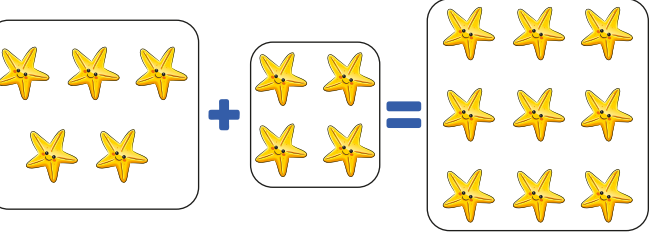
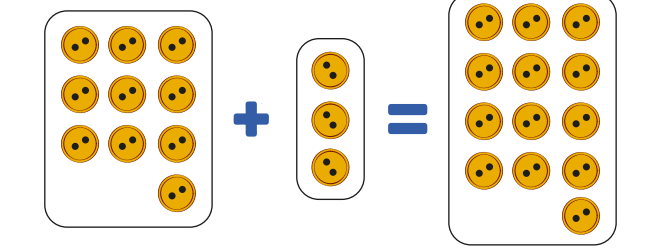
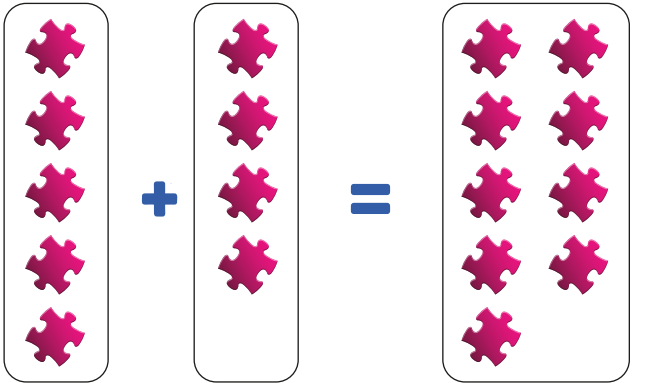

☞ Toplama işlemlerini sözlü olarak ifade edelim.

$$6 + 2 = 8$$

6 artı 2  
eşittir 8.



$$5 + 4 = 9$$

$$3 + 2 = 5$$

$$7 + 3 = 10$$

$$4 + 7 = 11$$

$$8 + 4 = 12$$

$$6 + 1 = 7$$

$$2 + 2 = 4$$

$$5 + 5 = 10$$



$$6 + 5 = 11$$

$$7 + 3 = 10$$

$$9 + 3 = 12$$

$$6 + 7 = 13$$

$$5 + 4 = 9$$

$$9 + 1 = 10$$

$$4 + 7 = 11$$

$$8 + 1 = 9$$

$$5 + 3 = 8$$

$$2 + 4 = 6$$



☞ Keselim, boyayalım, yapıştıralım. Çiçeklerimizi oluşturalım.

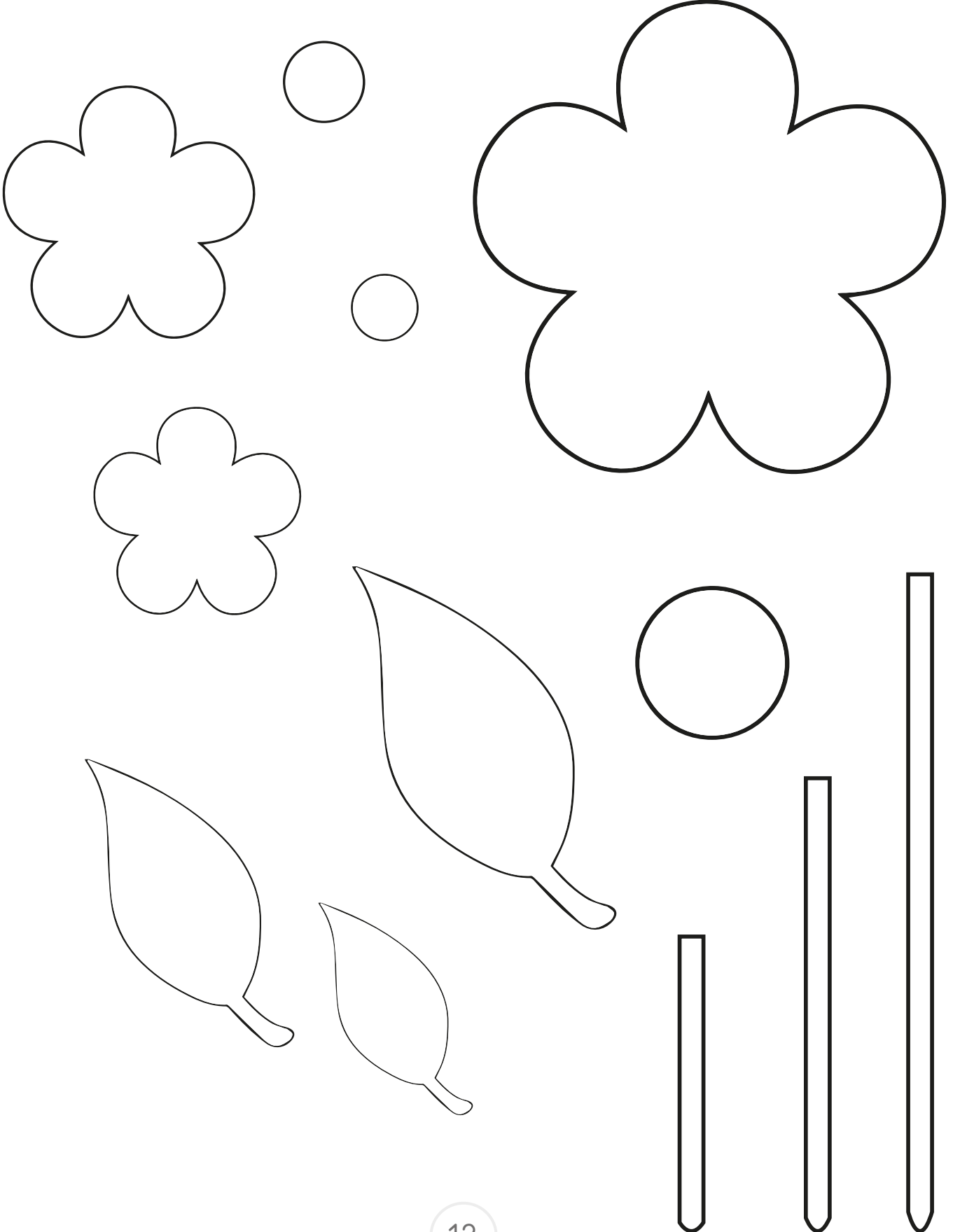



☞ Kartı noktalı yerlerden keselim. İçerisine öğretmenimiz için hissettiklerimizi yazalım. Öğretmenler Gününde öğretmenimize hediye edelim.

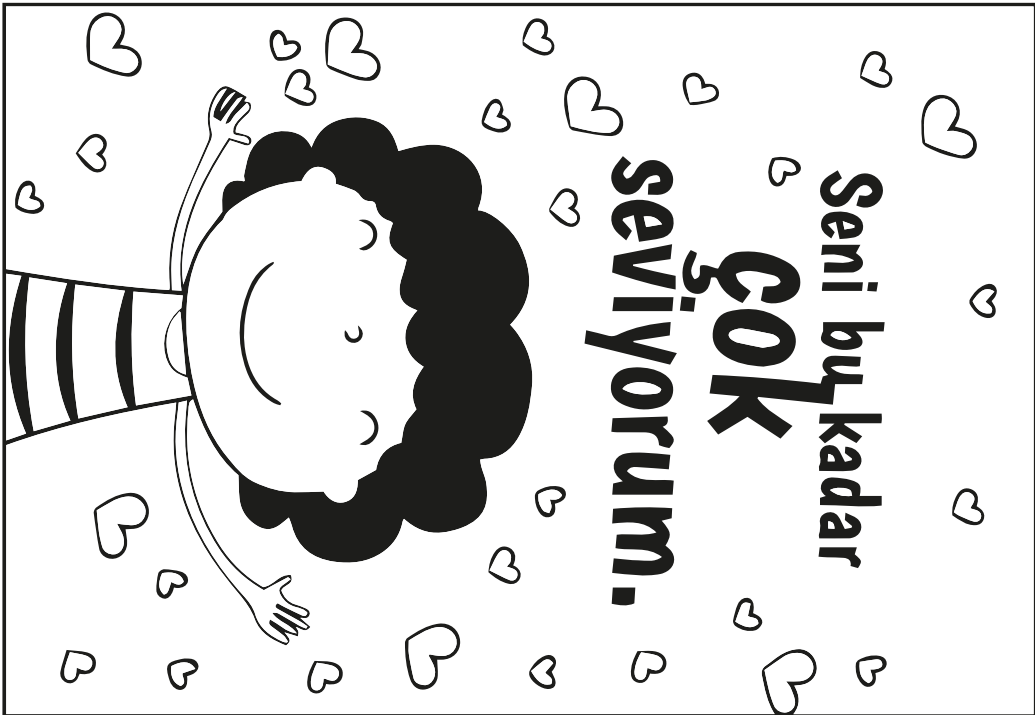
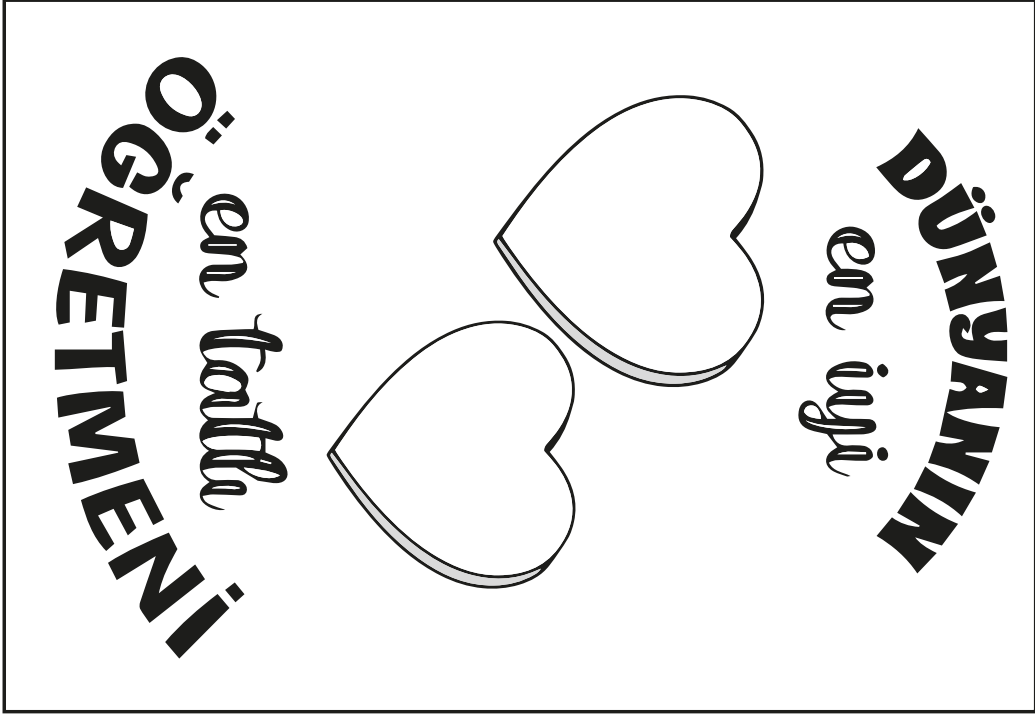



# BENİM ÇİZİMİMLE ÖĞRETMENİM

























**Etkinlik:** Siz de kartları kesip sıralayınız. Panonuza asıp önünde hatıra fotoğrafı çekiniz. Şimdiden bütün Öğretmenlerin Öğretmenler Günü'nü kutlarız.

